

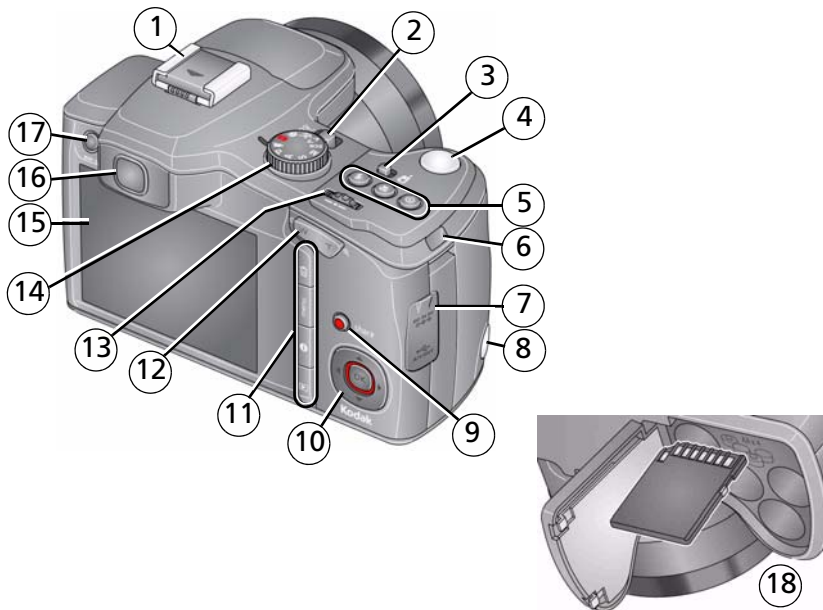



## Back, bottom view



- |  |   |
|--|---|
| 1 Hot shoe (for optional external flash) | 10 ◀/▶▶/▲/▼, OK                           |
| 2 Power button                           | 11 Delete/Menu/Info/Review buttons        |
| 3 On/Off for Portrait mode               | 12 Wide Angle/Telephoto button            |
| 4 Shutter button                         | 13 Jog dial                               |
| 5 Flash/Focus/Drive buttons              | 14 Mode dial                              |
| 6 Strap post (1 of 2)                    | 15 LCD                                    |
| 7 5V DC-In/USB/AV out                    | 16 EVF (Electronic viewfinder)            |
| 8 Portrait Shutter button                | 17 EVF/LCD button                         |
| 9 Share button                           | 18 SD/SDHC Card slot; battery compartment |

## Front view

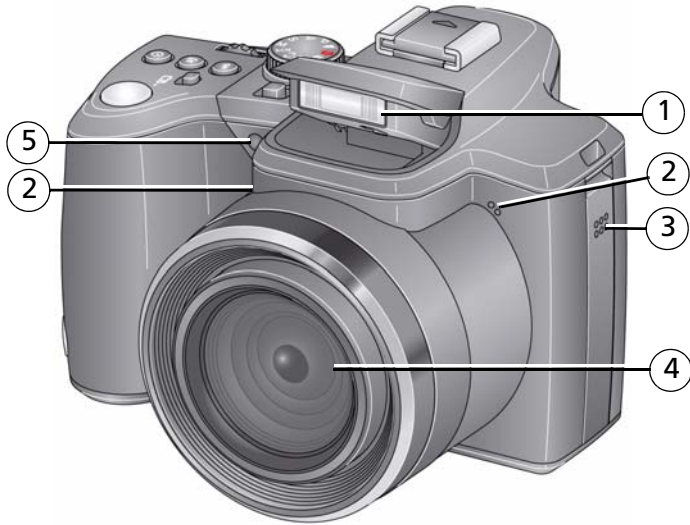

- 1 Flash
- 2 Microphones (2)
- 3 Speaker
- 4 Lens
- 5 Self-timer/Video/AF Assist light

---

# Table of contents

<b>1</b>	<b>Setting up your camera</b>	<b>1</b>
	Charging and loading the rechargeable batteries	1
	Turning on the camera	2
	Setting the language, date/time	2
	Attaching the strap	3
	Using the vertical grip (for portrait orientation)	4
	Storing pictures on an (accessory) SD or SDHC Card	5
	Using an (accessory) KODAK P20 Zoom Flash	6
	Using other (accessory) power options	7
<b>2</b>	<b>Taking pictures/videos</b>	<b>8</b>
	Taking a picture	8
	Taking a video	9
	Capture modes	11
	Using the zoom	13
	Using the flash	14
	Using the Drive button	15
	Using the Focus button	17
	Taking panoramic pictures	18
	P, A, S, and M modes	19
	Using exposure compensation to adjust brightness	21
	Using the histogram to view picture brightness	22
	Understanding the picture-taking icons	22
<b>3</b>	<b>Working with pictures/videos</b>	<b>23</b>
	Reviewing pictures/videos	23
	Deleting pictures/videos	24
	Using the menu button in Review	25
	Adding sound tags	26
	Cropping pictures	27
	Using KODAK PERFECT TOUCH Technology	28

Using the RAW Develop feature .....	29
Editing videos .....	30
Making a multimedia slide show .....	35
Viewing pictures as thumbnails .....	37
Selecting multiple pictures/videos .....	37
Using shortcuts .....	38
Copying pictures/videos.....	39
Understanding the review icons.....	39
<b>4 Using the menu button .....</b>	<b>40</b>
Using the Capture menu .....	40
Using the Capture + menu .....	42
Using the Setup menu .....	43
<b>5 Transferring, printing, and sharing pictures .....</b>	<b>47</b>
Installing the software.....	47
Transferring pictures with the USB cable.....	48
Transferring pictures using other options .....	49
Printing pictures .....	49
Tagging your pictures.....	51
<b>6 Troubleshooting .....</b>	<b>55</b>
<b>7 Getting help .....</b>	<b>60</b>
Getting help from your camera .....	60
Helpful links.....	61
<b>8 Appendix .....</b>	<b>63</b>
Camera specifications .....	63
Upgrading your software and firmware.....	66
Important safety instructions .....	66
Battery life .....	67
Care and maintenance .....	68
Limited warranty.....	68
Regulatory compliance .....	70

# 1

## Setting up your camera

### Charging and loading the rechargeable batteries

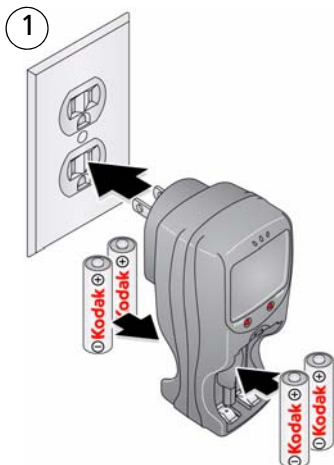

Lights are on while the charger is plugged in. (See the charger documentation for instructions and charging times.)

For longer life, charge KODAK Ni-MH Pre-Charged Rechargeable Batteries AA prior to use, and occasionally discharge them to depletion.



---

**See other power options** [see page 7](#)

---

**Extend battery life** [see page 67](#)

---

**Purchase accessories** [www.kodak.com/go/z980accessories](http://www.kodak.com/go/z980accessories)

---

## Turning on the camera

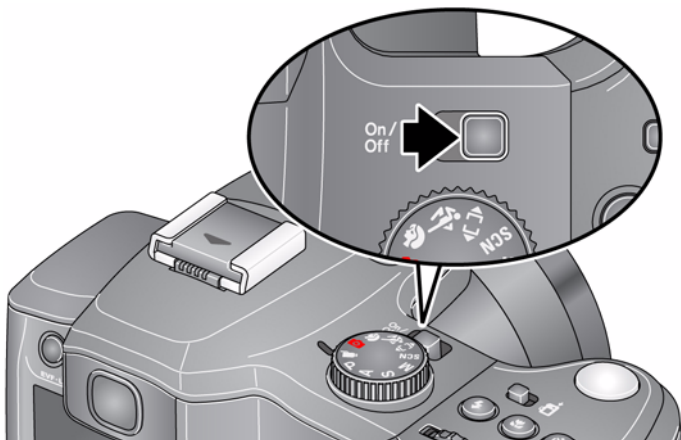

## Setting the language, date/time

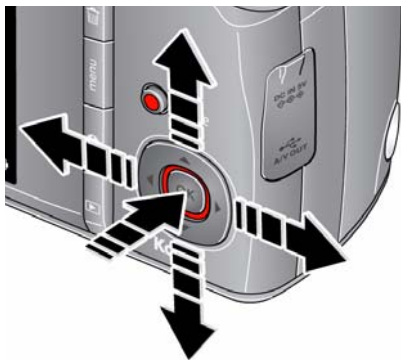

Language:  
▲/▼ to change.  
OK to accept.

Date/Time:  
At the prompt, press OK.  
▲/▼ to change current field.  
◀/▶ for previous/next field.  
OK to accept.

NOTE: To change language or date/time in the future, use the Setup menu ([see page 43](#)).

## Attaching the strap

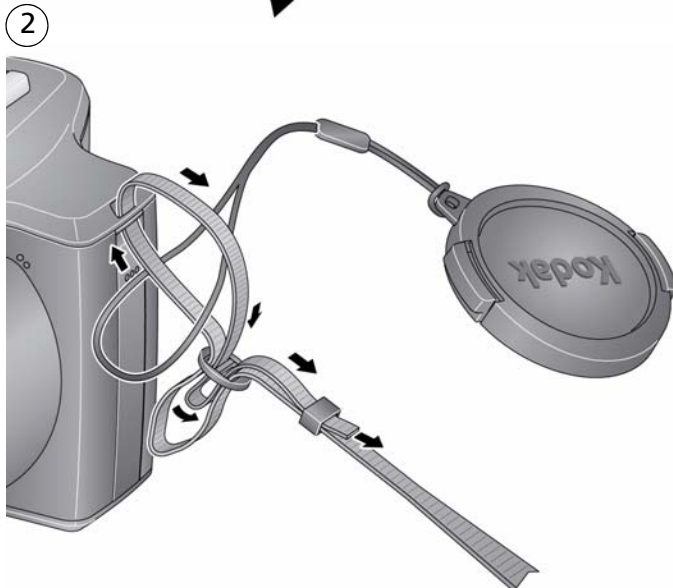
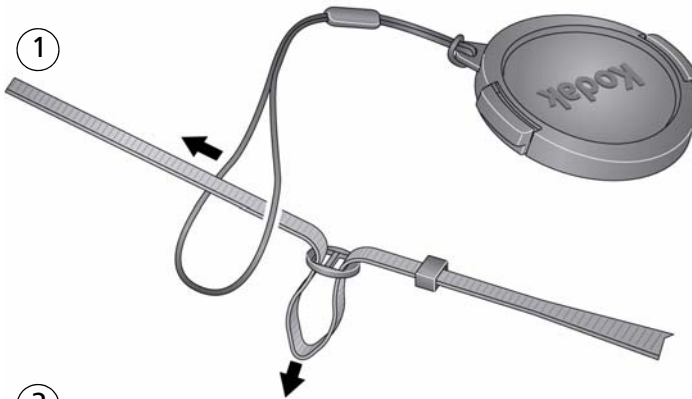

## Using the vertical grip (for portrait orientation)

The vertical grip makes it easier to take pictures in the vertical, portrait orientation.

- 1 Turn off the camera.
- 2 Attach and tighten the grip.
- 3 Turn on the camera.



- 4 Slide the Portrait switch.



- 5 Take pictures in the portrait orientation.

Use the Portrait Shutter button to take pictures.

Use  $\blacktriangle/\blacktriangledown$  to zoom.



---

Learn more about taking focused pictures [see page 8](#)

---

## Storing pictures on an (accessory) SD or SDHC Card

Your camera has internal memory. You can purchase an SD or SDHC Card to store more pictures and videos. (Maximum supported card size is 32 GB.)



### CAUTION:

A card can only be inserted one way; forcing it may cause damage. Inserting or removing a card when the camera is on may damage the pictures, the card, or the camera.

- 1 Turn off the camera.
- 2 Insert or remove the card.
- 3 Turn on the camera.

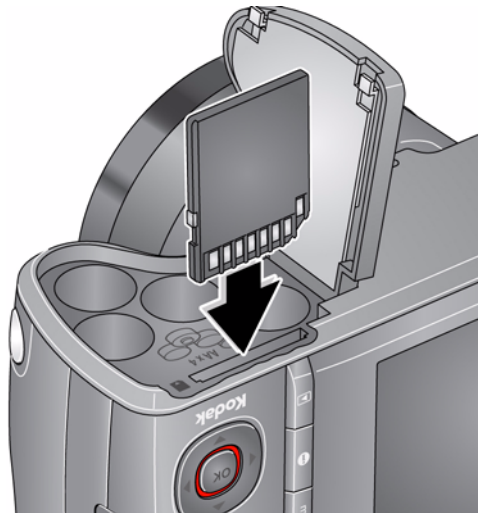

---

Purchase accessories [www.kodak.com/go/z980accessories](http://www.kodak.com/go/z980accessories)

---

## Using an (accessory) KODAK P20 Zoom Flash

- ① Turn off the camera.
- ② Remove the hot shoe cover from the camera.



- ③ Attach the KODAK P20 Zoom Flash.
- ④ Turn on the camera and the flash.



---

**For more information** See the flash documentation

**Purchase accessories** [www.kodak.com/go/z980accessories](http://www.kodak.com/go/z980accessories)

---

## Using other (accessory) power options

Use the KODAK 5-Volt AC Adapter to save battery power.

NOTE: The AC adapter does not charge the batteries.



---

**Purchase accessories** [www.kodak.com/go/z980accessories](http://www.kodak.com/go/z980accessories)

---

# 2

## Taking pictures/videos

### Taking a picture

- 1 Turn the Mode dial to Smart Capture .
- 2 Press the Shutter button halfway to lock the focus. When the framing marks turn green, press the Shutter button completely down.

EVF/LCD  
button

To save battery power,  
press the EVF/LCD  
button and use the  
electronic viewfinder.



NOTE: For more information on Smart Capture and other modes, [see page 11](#). Framing marks do not appear in some SCN (scene) and Video modes.

## Using the framing marks



Framing marks indicate the camera focus area.

- 1 Press the Shutter button **halfway**.

*If the camera is not focusing on the desired subject, release the Shutter button and recompose the scene.*

- 2 Press the Shutter button **completely down** to take the picture.

NOTE: Framing marks do not appear in all modes. Multiple framing marks may appear when faces are detected. When you press the Shutter button halfway down, the framing marks attempt to follow the main subject.

## Taking a video

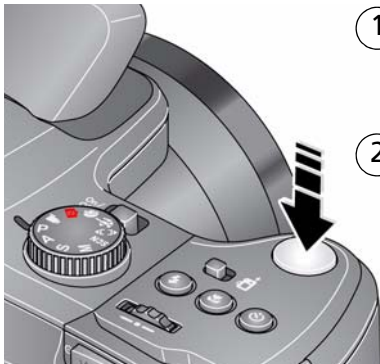

- ① Turn the Mode dial to Video .

- ② Press the Shutter button completely down and release. (To stop recording, press and release again.)

## Reviewing the picture/video just taken

After you take a picture/video, the LCD or EVF displays a quickview for several seconds. (To dismiss the quickview sooner, press the Shutter button halfway.) The picture/video is saved unless you press the Delete  button.







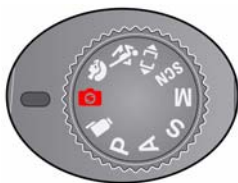

To review pictures/videos anytime, see [page 23](#).

## Capture modes







Choose the mode that best suits your subjects and surroundings.

Capture mode	For
 <b>Smart Capture</b>	General picture taking—it offers excellent image quality and ease of use. <ul style="list-style-type: none"> <li>■ Faces are detected.</li> <li>■ The scene is analyzed for other content and for lighting.</li> <li>■ KODAK PERFECT TOUCH Technology is applied, for better pictures.</li> </ul> You can choose the best picture size and aspect ratio for your needs—just press the Menu  button and choose Picture Size.
 <b>Portrait</b>	Full-frame portraits of people.
 <b>Sport</b>	Subjects that are in motion. Shutter speed is fast.
 <b>Panorama</b>	“Stitching” 2 or 3 pictures into 1 panoramic scene. (See <a href="#">page 18</a> .)
<b>SCN</b> <b>Scene</b>	Point-and-shoot simplicity when taking pictures under special conditions.
<b>P</b> <b>Program</b> <b>A</b> <b>Aperture</b> <b>S</b> <b>Shutter</b> <b>M</b> <b>Manual</b>	More creative control. (See <a href="#">page 19</a> ).
 <b>Video</b>	Video with sound. (See <a href="#">page 9</a> .)

## Scene modes

1 Turn the Mode dial to Scene **SCN**.

2 Press     to display Scene modes.

NOTE: If the mode description turns off before you finish reading it, press OK.

3 Press OK to choose a Scene mode.

<b>SCN mode</b>	<b>For</b>
<b>High ISO</b>	People indoors, in low-light scenes.
<b>Night Portrait</b>	Reducing red eye of people in night scenes or low-light conditions. Place the camera on a flat, steady surface or use a tripod.
<b>Landscape</b>	Far-away scenes. The camera uses infinity auto-focus. Auto-focus framing marks are not available in Landscape.
<b>Night Landscape</b>	Distant scenery at night. Flash does not fire. Place the camera on a flat, steady surface or use a tripod.
<b>Flower</b>	Close-ups of flowers or other small subjects in bright light. Focus is Macro.
<b>Sunset</b>	Capturing the deep hues seen at sunset.
<b>Backlight</b>	Subjects that are in shadow or "backlit" (when light is behind the subject).
<b>Candle light</b>	Capturing the ambiance of candle light.
<b>Manner/ Museum</b>	Quiet occasions, like a wedding or lecture. Flash is off.
<b>Text</b>	Documents. Focus is set to Macro.
<b>Beach</b>	Bright beach scenes.
<b>Snow</b>	Bright snow scenes.
<b>Fireworks</b>	Bright, colorful light displays. Flash does not fire. Place the camera on a flat, steady surface or use a tripod.
<b>Children</b>	Action pictures of children in bright light.
<b>Self-Portrait</b>	Close-ups of yourself. Assures proper focus and minimizes red eye.

SCN mode	For
Stage	People on a lit stage. Fast shutter speed, high ISO. Flash and sounds are off. (Flash setting can be changed.)

## Using the zoom

Use optical zoom to get up to 24X closer to your subject while taking pictures/videos.

**IMPORTANT:** *If the camera is in portrait mode (see page 4), press ▲/▼ to zoom.*

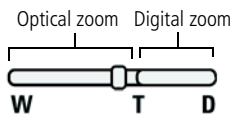

- 1 Use the LCD or EVF to frame your subject. (For focus distances, see [Camera specifications, page 63.](#))
- 2 Press Telephoto (T) to zoom in. Press Wide Angle (W) to zoom out.
- 3 Take the picture or video.

**NOTE:** To get a focused picture every time, remember:

- Use the auto focus framing marks, [page 8.](#)
- As you zoom in, move away from your subject.

## Using digital zoom

To turn on/off digital zoom, [see page 45.](#) (Digital zoom is not available in Smart Capture mode.)

**NOTE:** You may notice decreased image quality when using digital zoom. The slider on the LCD or EVF turns red when the picture quality reaches the limit for an acceptable 4 x 6-in. (10 x 15 cm) print.

## Using the flash

Use the flash when you take pictures at night, indoors, or outdoors in heavy shadows. Flash settings are limited in some capture modes.

NOTE: You can also attach an external flash. [See page 6.](#)



Press the flash button repeatedly to scroll through flash modes.

The current flash mode is shown on the LCD or EVF.

Flash modes	Flash fires	
<b>Auto</b>		When the lighting conditions require it.
<b>Fill</b>		Every time you take a picture, regardless of the lighting conditions. Use when the subject is in shadow or is "backlit" (when the light is behind the subject). In low light, hold the camera steady or use a tripod. NOTE: Not available in Smart Capture mode.
<b>Red-eye Reduction</b> To choose Preflash or Digital Correction, see <a href="#">page 44.</a>		A preflash fires, shrinking the eye pupil, before the picture is taken.
	Digital Correction 	A preflash does not fire; the camera corrects red eye. NOTE: When using digital correction, image processing takes longer than when using preflash.
<b>Off</b>		Never.

## Using the Drive button



Press the Drive button repeatedly to scroll through self-timer and burst modes.

The current flash mode is shown on the LCD.

## Using the self-timer

Use the self-timer when you want to be included in a picture, or to ensure a steady Shutter button press. Place the camera on a tripod or flat surface.

- 1 In any picture-taking mode, press the Drive button until the desired self-timer icon is displayed on the LCD.

**10 seconds**—  A picture is taken after a 10-second delay (so you have time to get into the scene).

**2 seconds**—  A picture is taken after a 2-second delay (for a steady, shutter release on a tripod).

**2 shot**—  The first picture is taken after a 10-second delay. A second picture is taken 8 seconds later.

- 2 Press the Shutter button **halfway** to focus and set exposure, then **completely down** to take the pictures.

*The camera takes the picture/pictures after the delay.*

Use the same procedure to take a 2- or 10-second self-timer video, but press the Shutter button **completely down**.



## Taking burst pictures



Press the Drive button repeatedly to scroll through self-timer and burst modes.

The current flash mode is shown on the LCD.

- 1 In most Still modes, press the Drive button until the desired burst icon is displayed on the LCD:

Mode	Icon	Description	Example
<b>Burst</b>		Camera takes 1 picture per second up to 6 pictures while the Shutter button is pressed.	A child blowing out birthday candles.
<b>High-speed Burst</b>		Camera takes 5 pictures per second up to 9 pictures while the Shutter button is pressed. (Picture sizes are 3.1 MP.)	A person swinging a golf club.

- 2 Press the Shutter button **halfway** to focus and set exposure, then **press and hold it completely down** to take the pictures.

*The camera stops taking pictures when you release the Shutter button, when the pictures are taken, or when there is no more storage space.*

NOTE: During quickview, you can delete all pictures in the burst series. To delete selectively, do so in Review (see [page 24](#)). Burst is unavailable in Portrait, Night Portrait, Night Landscape, Backlight, Fireworks, and Panorama modes.



## Using the Focus button



Press the Focus button repeatedly to scroll through Normal, Landscape, Macro, and Super Macro modes.

The current flash mode is shown on the LCD.

- 1 In most Still modes, press the Focus button until the desired focus icon is displayed on the LCD:

Mode	Icon	For
<b>Auto Focus (AF)</b>	No icon.	Normal picture taking.
<b>Landscape</b>		Distant scenery, or for taking pictures through a window.
<b>Macro</b>		Subjects that are 10–100 cm (3.9–39.4 in.) from the lens.
<b>Super Macro</b>		Subjects that are 1–30 cm (0.4–11.8 in.) from the lens.

- 2 Press the Shutter button **halfway** to focus and set exposure, then **completely down** to take the picture.

## Taking panoramic pictures

Use panorama to “stitch” up to 3 pictures into a panoramic scene.

NOTE: Individual picture sizes are approximately 3.1 MP (but may vary depending on scene content).

Individual pictures are not saved, even if panorama capture is cancelled before stitching occurs.

(Exposure Compensation, White Balance, Exposure Metering, AF Zone, AF Control, Color Mode, and Sharpness are set with the first picture. The flash is set to Off.) You can use the self-timer (2- and 10-second delays) while taking panoramic pictures. [See page 15.](#)

- 1 Turn the Mode dial to Panorama ◀[ ]▶.
- 2 Press ◀/▶ to highlight Panorama Left-Right or Panorama Right-Left (depending on the direction you want to pan), then press OK.
- 3 Take the first picture.  
*After a quickview, the LCD or EVF displays the liveview and an “overlay” from the first picture.*
- 4 Compose the second picture. Make the overlay from the first picture cover the same portion in the new picture.
- 5 If you are taking only 2 pictures, press OK to stitch them together.  
*After you take 3 pictures, the pictures are automatically stitched together.*

Take 2 or 3 pictures.



Get 1 panoramic picture.



## P, A, S, and M modes

Use these modes when you want more control over your camera and pictures.







Mode	When to use	Press Jog dial to control
<b>P</b>	<b>Program</b> mode offers the ease of auto shooting with full access to all menu options. The camera automatically sets the shutter speed and aperture (f-stop) based on the scene lighting.	Exposure compensation (how much light enters the camera), flash compensation, and ISO speed
<b>A</b>	<b>Aperture Priority</b> mode controls depth of field (the range of sharpness). The aperture setting may be affected by optical zoom.	Aperture, exposure compensation, flash compensation, and ISO speed
<b>S</b>	<b>Shutter Priority</b> mode prevents blur when your subject is moving. The camera automatically sets the aperture for proper exposure. (To prevent blur, use a tripod for slow shutter speeds.)	Shutter speed, exposure compensation, and flash compensation
<b>M</b>	<b>Manual</b> mode offers the highest level of creative control. (To prevent blur, use a tripod for slow shutter speeds.)	Aperture, shutter speed, flash compensation, and ISO speed

**NOTE:** Settings you change in P, A, S, or M modes apply only to pictures taken in those modes. The settings, including Flash, are maintained for P, A, S, and M modes—even when you change modes or turn off the camera. Use Reset Camera ([see page 45](#)) to reset P, A, S, or M modes to their default setting.

## Changing P, A, S, or M mode settings

PASM modes control the aperture (f-number, also known as f-stop), shutter speed, exposure compensation, flash compensation, and ISO. Use the Menu  button to control all other settings.

- 1 Turn the Mode dial to P, A, S, or M.
- 2 Turn the Jog dial   to highlight a setting, then press it to edit the setting.  
Turn the Jog dial   to change a setting, then press it to save it. (See [page 19](#).)

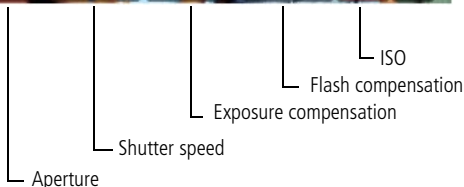
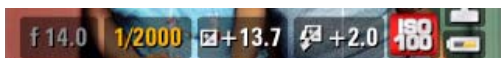

NOTE: A yellow setting indicates possible unsatisfactory results. (However, you can still take the picture.)

**ISO**—adjust the camera’s sensitivity to light. Higher ISO indicates greater sensitivity.

NOTE: A higher ISO may produce unwanted “noise” in a picture. ISO 3200 and 6400 are available only in 3.1 MP and lower picture sizes. (In Smart Capture mode, ISO 1600 is the maximum.)

**Flash Compensation**—adjust flash brightness.

**Exposure Compensation**—adjust the exposure. If the scene is too light, decrease the setting; if it’s too dark, increase the setting.

**Shutter speed**—control how long the shutter stays open. (Use a tripod for slow shutter speeds.)

**Aperture**—(also known as f-stop) control the size of the lens opening, which determines the depth of field.

- Smaller f-stop numbers indicate a larger lens opening; good for low-light.
- Larger f-stop numbers indicate a smaller lens opening; keeps the main subject sharp; good for landscapes and well-lit conditions.

## Using exposure compensation to adjust brightness

In P, A, S, and Panorama modes, you can adjust exposure compensation before you take a picture to make your pictures darker or lighter. Only the first picture in Panorama mode can be adjusted—that adjustment is applied to the remaining pictures. (For more about the Jog dial, [see page 19](#). For more about Exposure Compensation, [see page 20](#).)

- 1 Turn the Jog dial ◀/▶ to highlight Exposure Compensation, then press it to edit the setting. Turn the Jog dial ◀/▶ to change the setting, then press it to save it.

*An exposure compensation level is shown on the LCD or EVF and the image gets darker or lighter.*

- 2 Take the picture when you are satisfied with the exposure compensation level.

## Using exposure compensation with exposure bracketing

You can use exposure compensation ([see page 21](#)) in conjunction with exposure bracketing to get the best exposure.

If the exposure compensation is set to:	And if the exposure bracketing interval is set to 0.3 steps:	Then the exposures taken are:
0.0	Set the Exposure Bracketing Interval	-0.3, 0.0, +0.3
+1.0	in the Capture + menu ( <a href="#">see page 43</a> ).	+0.7, +1.0, +1.3
-1.0		-1.3, -1.0, -0.7

## Using the histogram to view picture brightness

Use the histogram to evaluate the distribution of light before or after you take a picture. Optimal exposure is achieved when the peak is in the middle of the histogram. The flash may affect a picture's light and shadow.

To show the histogram in P, A, S, M modes or in Review, press the Info **i** button until the histogram appears.

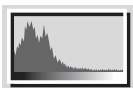

Dark picture

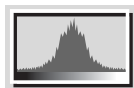

Balanced picture

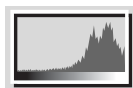

Bright picture

## Understanding the picture-taking icons

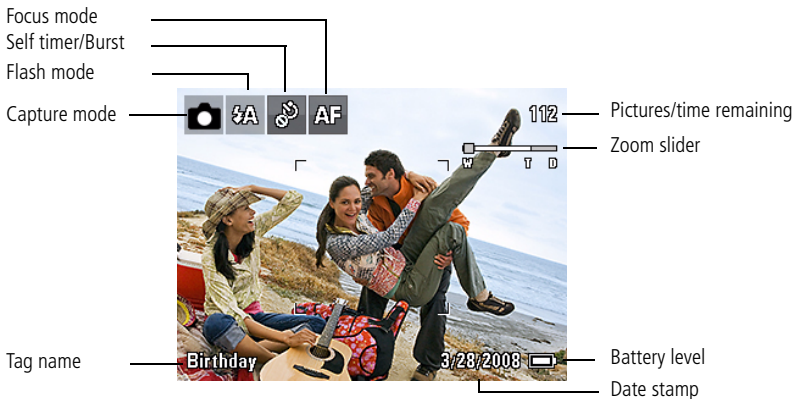



# 3

## Working with pictures/videos

### Reviewing pictures/videos





Press the Review  button to view and work with your pictures/videos. Press Review again to exit.



- 1 Press the Review  button.
- 2 Press   for previous/next picture/video.
  - Press the Shutter button halfway down to return to Capture mode.
  - To view pictures/videos as thumbnails, see [page 37](#).







### Magnifying a picture during review

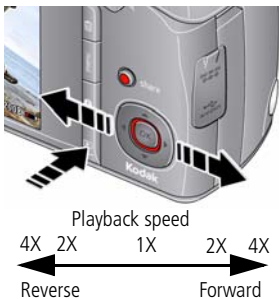



- 1 Press Telephoto (T) to zoom in.
- 2 Press     to view other parts of a picture.
  - Press OK to return to 1X.

## Playing a video



- 1 Press the Review  button.
- 2 Press  to locate previous/next video.
- 3 Press OK to play a video.
  - Press  during playback to adjust the volume.
  - Press OK to pause/resume. (Press  during pause to go to previous/next frame.)
  - Press  during playback to play at 2X speed; press again for 4X. (Press  during 4X to jump to a bookmark. See [page 32](#).)
  - Press  during playback to reverse at 2X speed; press again for 4X.

## Deleting pictures/videos





- 1 Press the Review  button.
- 2 Press  to find a picture/video.
- 3 Press the Delete  button.
- 4 Follow the screen prompts.

NOTE: If you have multiple pictures to delete, you can select then delete them. See [page 37](#).

## Using the undo delete feature

If you accidentally delete a picture, you may be able to use Undo Delete to retrieve it. This feature is only available immediately after you delete a picture.

## Protecting pictures/videos from deletion

- 1 Press the Review  button, then  to find a picture.
- 2 Press the Menu  button.
- 3 Press  to highlight Protect, then press OK.  
*The Protect icon  appears with the protected picture/video.*
  - Press the Menu button to exit the menu.







### CAUTION:

**Formatting internal memory or an SD or SDHC Card deletes all (including protected) pictures/videos. (Formatting internal memory also deletes email addresses, tag names, and favorites.)**

**IMPORTANT:** *Your camera offers an on-board Help system. To get the most from your camera, [see page 60](#).*

## Using the menu button in Review





- 1 Press the Review  button, then the Menu  button.
- 2 Press  to choose a tab:
  - **Review** to view pictures/videos
  - **Edit** to edit pictures/videos
  - **Setup** for other camera settings
- 3 Press  to highlight a setting, then press OK.
- 4 Choose an option, then press OK.

## Adding sound tags

You can add a recording (up to 1 minute long) to a picture.

NOTE: Only one sound tag can be added to each picture (not to videos).

### Recording a sound tag





- 1 Press the Review  button, then  to find a picture.
- 2 Press the Menu  button, then  to highlight the Edit tab.
- 3 Press  to highlight Sound Tag, then press OK.
- 4 Follow the screen prompts.

*The sound tag is applied to your picture.*

- Press the Menu button to exit the menu.

**IMPORTANT:** *Your camera offers an on-board Help system. To get the most from your camera, [see page 60](#).*





### Playing a sound tag

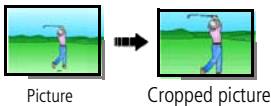

- 1 Press the Review  button, then  to find a picture with a “Play Sound Tag” prompt.
- 2 Press  to play the sound tag.
- 3 Press  to adjust the volume.
  - Press OK to stop playback.

## Cropping pictures

You can crop a picture so that only the desired portion of the picture remains. (You cannot crop these pictures: panoramic, 16:9, video action prints, pictures from a video, or pictures that are already cropped.)



- 1 Press the Review  button, then  to find a picture.
- 2 Press the Menu  button, then  to highlight the Edit tab.

- 3 Press  to highlight Crop, then press OK.
- 4 Press Telephoto (T) to zoom in, or   to move the crop box. Press OK.
- 5 Follow the screen prompts.







*The picture is cropped, the original saved. (Cropped pictures cannot be cropped again.)*

- Press the Menu button to exit the menu.

**IMPORTANT:** *Your camera offers an on-board Help system. To get the most from your camera, [see page 60](#).*

## Using KODAK PERFECT TOUCH Technology

KODAK PERFECT TOUCH Technology helps ensure better, brighter pictures. PERFECT TOUCH Technology is automatically applied to pictures taken in Smart Capture mode. (You cannot enhance videos, panoramic pictures, or pictures that are already enhanced.)







- 1 Press the Review  button, then  to find a picture.
  - 2 Press the Menu  button, then  to highlight the Edit tab.
  - 3 Press  to highlight Perfect Touch tech, then press OK.  
*A preview is shown in a split screen. Press  to view other parts of the picture.*
  - 4 Press OK. Follow the screen prompts to replace the original picture or to save the enhanced picture as a new one.
- Press the Menu button to exit the menu.

**IMPORTANT:** *Your camera offers an on-board Help system. To get the most from your camera, [see page 60](#).*

## Using the RAW Develop feature

In P, A, S, M, Sport, Portrait, and SCN modes, you can take pictures as the RAW file type. The RAW Develop feature lets you develop, edit (picture size, quality, exposure compensation, color mode, sharpness, and white balance), and save RAW files as Fine, Standard, or Basic. (The original RAW file is preserved.)

You can edit RAW files in KODAK EASYSHARE Software.

- 1 Press the Review  button, then  to find a picture.
- 2 Press the Menu  button, then  to highlight the Capture + tab.
- 3 Press  to highlight RAW File Develop, then press OK.
- 4 Press  to highlight options and to make adjustments:
  - Picture Quality
  - File Type
  - Exposure Compensation
  - Color Mode
  - Sharpness
  - White Balance
- 5 When finished, press  to highlight Develop RAW File, then press OK.







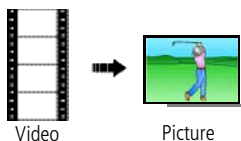

**IMPORTANT:** *Your camera offers an on-board Help system. To get the most from your camera, [see page 60](#).*

## Editing videos

### Making a picture from a video

You can choose a single frame from a video, then make a picture suitable for printing.



- 1 Press the Review  button, then  to find a video.
- 2 Press the Menu  button, then  to highlight the Edit tab.
- 3 Press  to highlight Make Picture, then press OK.
- 4 Press  to highlight the Play icon, then press OK to play the video. (Press OK to pause. Press  to navigate through video frames.)
- 5 During play or pause, press  to highlight the Make a Picture icon, then press OK.

*A picture is created. (The original video is saved.)*





- Press the Menu button to exit the menu.

**IMPORTANT:** *Your camera offers an on-board Help system. To get the most from your camera, [see page 60](#).*

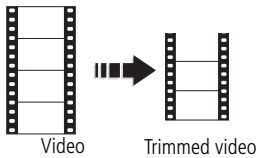
## Trimming a video

You can delete an unwanted portion from the beginning or end of a video.



- 1 Press the Review  button, then  to find a video.
- 2 Press the Menu  button, then  to highlight the Edit tab.
- 3 Press  to highlight Trim, then press OK.
- 4 Follow the screen prompts.
 

*The video is trimmed. (You can save it as a new video or replace the original.)*

  - Press the Menu button to exit the menu.







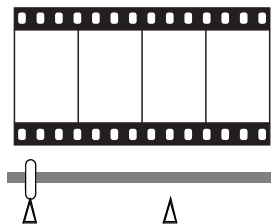

**IMPORTANT:** Your camera offers an on-board Help system. To get the most from your camera, [see page 60](#).

## Using video bookmarks

You can set bookmarks at interesting places in your video, then jump from one bookmark to another.

### Setting bookmarks





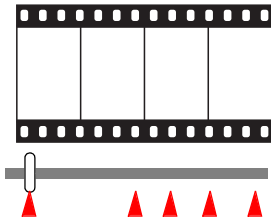

- 1 Press the Review  button, then  to find a video.
- 2 Press the Menu  button, then  to highlight the Edit tab. Highlight Bookmark, then press OK.
- 3 Press  to highlight Create/Edit, then press OK.
- 4 Press  to highlight the Play icon, then press OK to play the video. (Press OK to pause. Press  to navigate through video frames.)
- 5 During play or pause, press  to highlight Add Bookmark, then press OK. When finished adding up to 9 bookmarks, highlight , then press OK.  
*A picture is created. (The original video is saved.)*  
■ Press the Menu button to exit the menu.

**IMPORTANT:** *Your camera offers an on-board Help system. To get the most from your camera, [see page 60](#).*

## Using bookmarks





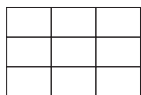
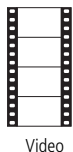

- 1 Press the Review  button, then  to find a video.
- 2 Press  to play the video. To jump to the first bookmark, press and hold  for 4 seconds while the video is playing.
  - After you jump to a bookmark, press  to jump to other bookmarks.
  - To view all bookmarked video frames, press the Wide Angle (W) button. To return to normal view, press the Telephoto (T) button.

## Making a video action print

From a video, you can make a 4-, 9-, or 16-up picture, suitable for a 4 x 6-inch (10 x 15 cm) print.



4-, 9-, or  
16-up picture

- 1 Press the Review  button, then  to find a video.
- 2 Press the Menu  button, then  to highlight the Edit tab.
- 3 Press  to highlight Action Print, then press OK. Choose an option, then press OK:

- Auto options: The camera includes the first and last frames, then 2, 7, or 14 equally spaced frames.
- Manual: You choose the first and last frames; the camera chooses 2, 7, or 14 equally spaced frames.
- Use Bookmarks: Bookmarked frames are used.







*A 4-, 9-, or 16-up picture is created. If you have less than 4 or 9 bookmarks, equally spaced video frames are used.*

- Press the Menu button to exit the menu.

## Making a multimedia slide show

Use Multimedia Slide Show to display your pictures/videos on the LCD or EVF. You can play all pictures/videos, or select pictures to include in the slide show. You can customize your slide show to include music and your choice of transitions. You can even save a slide show.

### Make a multimedia slide show that you can save







- 1 Press the Review  button. Select 2-100 pictures (see [page 37](#)).
- 2 Press the Menu  button, then /  to highlight the Review tab. Highlight Multimedia Slide Show, then press OK.
- 3 Press /  to highlight Preview Show, then press OK.

*Each picture/video is displayed once. To interrupt the slide show, press OK. After the slide show plays, you may save or modify it.*

**IMPORTANT:** *Your camera offers an on-board Help system. To get the most from your camera, see [page 60](#).*

### Play a multimedia slide show loop

When you turn on Loop, the slide show is continuously repeated.

- 1 On the Multimedia Slide Show menu, press /  to highlight Loop, then press OK.
- 2 Press /  to highlight On, then press OK.
- 3 Press /  to highlight Preview Show, then press OK.

*The slide show repeats until you press OK or until the battery is exhausted.*

## Displaying pictures/videos on a television

You can display pictures/videos on a television, computer monitor, or any device equipped with a video input. To connect the camera to a television, use an A/V cable (may be sold separately).

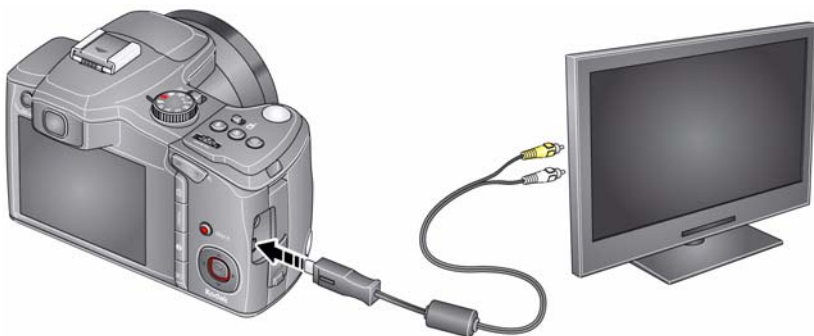

NOTE: Ensure that the Video Out setting (NTSC or PAL) is correct ([see page 45](#)). (Image quality on a television screen may not be as good as on a computer monitor or when printed.)

## Viewing pictures as thumbnails

- 1 Press the Review  button.
- 2 Press the Wide Angle (W) button to change from single-picture view to multi-up thumbnails.
- 3 Press Telephoto (T) to return to single-picture view.
  - To select multiple pictures/videos, see [Selecting multiple pictures/videos](#).
  - Press the Review button to exit Review.

NOTE: This feature is available as a shortcut. See [page 38](#).

## Selecting multiple pictures/videos

Use the multi-select feature when you have two or more pictures/videos to print or delete. (Multi-select can also be used in Multi-Up mode, [Viewing pictures as thumbnails](#).)

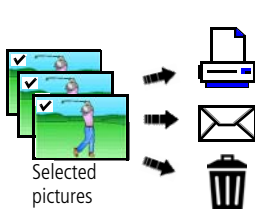

- 1 Press the Review  button, then   to find a picture/video.
- 2 Press OK to select pictures/videos.

*A check mark appears on the picture. You can now print or delete the selected pictures. You can press OK a second time to remove a check mark.*

## Using shortcuts

For quick access to the most popular functions:

- 1 Press the Info **i** button.

*The shortcuts appear.*

- 2 Press ▲/▼ to choose Select Photo, Tag, View Thumbnails, or Play Video.

To hide the shortcuts again, press **i**.





## Copying pictures/videos

You can copy pictures/videos from a card to internal memory or from internal memory to a card.

NOTE: Before you copy, make sure that a card is inserted in the camera.

### Copy pictures/videos:

- 1 Press the Review  button, then the Menu  button.
- 2 Press  $\blacktriangle/\blacktriangledown$  to highlight Copy, then press OK.
- 3 Press  $\blacktriangle/\blacktriangledown$  to highlight an option, then press OK.

NOTE: Pictures/videos are copied, not moved. To remove pictures/videos from the original location after copying, delete them (see [page 24](#)).

**IMPORTANT:** *Your camera offers an on-board Help system. To get the most from your camera, see [page 60](#).*

## Understanding the review icons

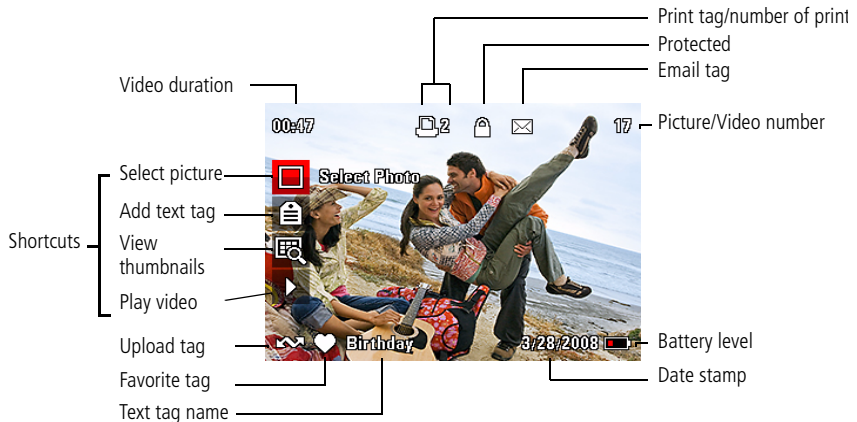





# 4

## Using the menu button

### Using the Capture menu

You can change settings to get the best results from your camera.

NOTE: Some modes offer limited settings. Some settings remain until you change them; others, until you change modes or turn off the camera.

- 1 Press the Menu  button.
- 2 Press  to highlight a tab. (You may need to press  to highlight a tab.)
  - **Capture/Video** for the most common picture/video-taking settings
  - **Setup** for other camera settings
- 3 Press  to highlight a setting, then press OK.
- 4 Highlight an option, then press OK. (Some options let you use .)

IMPORTANT: *Your camera offers an on-board Help system. To get the most from your camera, [see page 60](#).*

---

#### Press Menu, , , , , Capture Options and OK to access settings

---

#### Picture Size

Choose a picture resolution.

See [Camera specifications, page 63](#).

#### Video Size

Available only in Video mode.

**HD** (1280 x 720 @ 30 fps)

**VGA** (640 x 480 @ 30 fps)

**QVGA** (320 x 240 @ 30 fps)

#### AF Control (Video)

Choose a focus setting.

**Single**—camera focuses when the Shutter button is pressed.

**Continuous**—camera focuses continuously.

---

---

Press Menu, ◀/▶, ▲/▼, Capture Options  
and OK to access settings

---

**Color Mode**

Choose color tones for pictures.

**High Color**

**Natural Color**

**Low Color**

**Black & White**

**Sepia**

NOTE: KODAK EASYSHARE Software also lets you change a color picture to black-and-white or sepia.

---

**Picture Quality**

Choose how much compression is applied to pictures.

Not available in Smart Capture mode.

**Fine**—least compression; best quality, and largest file size.

**Standard**—medium compression; medium quality, and medium file size.

**Basic**—most compression; lowest quality, and smallest file size.

**RAW**—unprocessed image data in its original state (to which white balance, contrast, etc. have not been applied). You can use the RAW Develop feature to create a JPG copy for printing (see page 29).

---

## Using the Capture + menu

---

Press Menu, , , , , and OK to access settings

### Capture + Options

#### White Balance

Choose your lighting condition.

Available only in P/M and Panorama modes.

**Auto**—automatically corrects white balance. Ideal for general picture taking.

**Daylight**—for pictures in natural lighting.

**Tungsten**—corrects the orange cast of household light bulbs. Ideal for indoor pictures under tungsten or halogen lighting without flash.

**Fluorescent**—corrects the green cast of fluorescent lighting. Ideal for indoor pictures under fluorescent lighting without flash.

**Open Shade**—for pictures in shade in natural lighting.

#### Exposure Metering

Evaluate light levels at specific areas of a scene.

Available only in P/M and Panorama modes.

**Multi-pattern**—evaluates lighting conditions throughout the image to give an optimum picture exposure. Ideal for general picture taking.

**Center-weighted**—evaluates the lighting conditions of the subject centered in the LCD or EVF. Ideal for backlit subjects.

**Spot**—similar to Center-weighted, except the metering is concentrated on a smaller area of the subject centered in the LCD or EVF.





#### AF Zone

Select a large or concentrated area of focus.

Available only in P/M and Panorama modes.

**Multi-zone**—evaluates 5 zones to give an even picture focus. Ideal for general picture taking.

**Center-zone**—evaluates the small area centered in the LCD. Ideal when precise focus of a specific area in the picture is needed.

Press Menu, , , , , and OK to access settings

### Capture + Options

#### Exposure Bracketing Interval

Choose the difference in exposure compensation while using exposure bracketing. Available only in P/M mode.

**Off**  
**+/- 0.3 EV**  
**+/- 0.7 EV**  
**+/- 1.0 EV**  
 See [page 21](#).

#### Sharpness

Control picture sharpness. Available only in P/M and Panorama modes.

**Sharp**  
**Normal**  
**Soft**

## Using the Setup menu

Press Menu, , , , , and OK to access settings

### Setup Options

#### Share Button

Choose how pictures/videos are handled when you press the Share button (via EASYSHARE Software for WINDOWS OS only).

NOTE: Some online services limit video file sizes. Where applicable, use EASYSHARE Software to choose a preferred online service.

**Favorite and Upload**—pictures/videos are tagged as Favorites and uploaded to your preferred online service when you connect to your computer or network.

**Favorite**—pictures/videos are tagged as Favorites (5-star in EASYSHARE Software, on your computer).

**Upload**—pictures/videos are uploaded to your preferred online service when you connect to your computer or network.

#### LCD Brightness

**1, 2, 3, 4, 5**—dimmett to brightest. (Use a dimmer setting to save battery power.)

Press Menu, ◀/▶, ▲/▼, and OK to access settings

## Setup Options

### Image Storage

Choose a storage location for pictures/videos.

**Auto**—the camera uses the card if one is in the camera. If not, the camera uses internal memory.

**Internal Memory**—the camera uses internal memory, even if a card is installed.

### Set Tag

Assign tag names to pictures/videos. Select tag name(s) before you take pictures or videos. Then, new pictures/videos are assigned that tag name(s).

### Clear All

### Add Tag

### Delete Tag

### Exit

### Tag Name 1

### Tag Name 2

See [page 51](#).

### Capture Frame Grid

Use the frame grid to divide the LCD screen into thirds, vertically and horizontally.

**On**

**Off**

### Date Stamp

Imprint the date on pictures.

**On**

**Off**

### Red-eye Reduction

The Red-eye flash fires automatically before a picture is taken.

**Preflash**—the flash fires to reduce the chance of red-eye.

**Digital correction**—the camera digitally corrects red-eye after a picture is taken.

### Image Stabilizer

Choose if image stabilization is on or off.

**On**





**Off**

### Quickview

Show a picture/video as soon as it is taken.

**On**

**Off**

<b>Press Menu, , , , , and OK to access settings</b>	<b>Setup Options</b>
<p><b>Advanced Digital Zoom</b> Zoom using optical, then digital zoom. Not available in Smart Capture mode.</p>	<p><b>Pause</b>—zooming pauses at the optical zoom maximum. To use digital zoom, release then press the Telephoto (T) zoom button.</p> <p><b>None</b>—digital zoom is off.</p>
<p><b>Orientation Sensor</b> Orient pictures so that they are displayed with the correct side up.</p>	<p><b>On</b></p> <p><b>On Transfer</b> (when used with KODAK EASYSHARE Software)</p> <p><b>Off</b></p>
<b>Camera Sounds</b>	Turn on/off sound effects for each camera function.
<b>Sound Volume</b>	<p><b>High</b></p> <p><b>Medium</b></p> <p><b>Low</b></p> <p><b>Off</b></p>
<b>Date &amp; Time</b>	See <a href="#">page 2</a> . The format chosen is used for all date/time features.
<p><b>Auto Power Off</b> Choose inactivity time until camera turns off.</p>	<p><b>10 minutes</b></p> <p><b>5 minutes</b></p> <p><b>3 minutes</b></p> <p><b>1 minute</b></p>
<p><b>Video Out</b> Choose the regional setting for connecting to a television or other external device.</p>	<p><b>NTSC</b>—used in North America and Japan.</p> <p><b>PAL</b>—used in Europe and China.</p>
<b>Language</b>	See <a href="#">page 2</a> .
<b>Reset Camera</b>	Reset all camera settings to their defaults. (After using the Reset Camera feature, turn the camera off and then on again.)

Press Menu, ◀/▶, ▲/▼, and OK to access settings

## Setup Options

### Format



**CAUTION:**  
Formatting deletes all pictures/videos, including those that are protected.

**Memory Card**—deletes everything on the card; formats the card.

**Cancel**—exits without making a change.

**Internal Memory**—deletes everything in internal memory including email addresses, and tag names; formats the internal memory.

### About

View camera firmware version.

---

# 5

## Transferring, printing, and sharing pictures

### Installing the software



#### CAUTION:

Install EASYSHARE Software *before* connecting the camera to the computer. Failure to do so may cause the software to load incorrectly.

- 1 Close all software applications that are open on your computer (including anti-virus software).
- 2 Place the EASYSHARE Software CD into the CD-ROM drive.
- 3 Load the software:

**WINDOWS OS**—if the install window does not appear, choose Run from the Start menu and type **d:\setup.exe** where **d** is the drive letter that contains the CD.

**MAC OS X**—double-click the CD icon on the desktop, then click the Install icon.

- 4 Follow the on-screen instructions to install the software.

NOTE: When prompted, take a few minutes to electronically register your camera and software. To register later, see [www.kodak.com/go/register](http://www.kodak.com/go/register).

- 5 If prompted, restart the computer. If you turned off anti-virus software, turn it back on. See the anti-virus software manual for details.

For software help, click the Help button in EASYSHARE Software.

## Transferring pictures with the USB cable

- ① Turn off the camera.
- ② Connect the KODAK USB Cable, Model U-8.
- ③ Turn on the camera.

KODAK EASYSHARE Software opens on your computer and prompts you through the transfer process.



---

Learn more about connecting

[www.kodak.com/go/howto](http://www.kodak.com/go/howto)

## Transferring pictures using other options

You can also use a card reader to transfer your pictures/videos.

## Printing pictures

### Direct printing with a KODAK All-in-One Printer

Your camera is compatible with PICTBRIDGE Technology, so you can print directly to PICTBRIDGE Technology enabled Printers. You need a camera with fully charged battery, a PICTBRIDGE Technology enabled Printer, and a USB cable.

- 1 Turn **off** the printer. Turn **on** the camera.
- 2 Connect the appropriate USB cable from the camera to the printer.  
*The PICTBRIDGE Technology logo is displayed, followed by the current picture and menu. (If no pictures are found, a message is displayed.) If the menu turns off, press any button to redisplay it.*
- 3 Highlight a printing option, then press OK.
  - Current Picture**—Press ◀/▶ to choose a picture. Choose the number of copies.
  - Tagged Pictures**—Print pictures that you tagged for printing and choose a print size.
  - Index Print**—Print thumbnails of all pictures. (This option requires one or more sheets of paper.) If the printer is capable, choose a print size.
  - All Pictures**—Print all pictures in internal memory or on a card. Choose the number of copies.
  - Image Storage**—Access Auto or Internal Memory.

### Disconnecting the camera from a KODAK All-in-One Printer

- 1 Turn off the camera and printer.
- 2 Disconnect the USB cable from the camera and the printer.

## **Using a printer that is not PICTBRIDGE Technology enabled**

After you transfer pictures from the camera to your computer, you can print them from EASYSHARE Software. For details, see Help in EASYSHARE Software.

## **Ordering prints online**

KODAK Gallery ([www.kodakgallery.com](http://www.kodakgallery.com)) is one of the many online print services offered in EASYSHARE Software. You can easily:

- Upload your pictures.
- Edit, enhance, and add borders to your pictures.
- Store pictures, and share them with family and friends.
- Have prints, photo greeting cards, frames, and albums delivered to your door.

## **Printing from an optional SD or SDHC Card**





- Automatically print tagged pictures when you insert your card into a printer with an SD/SDHC Card slot. See your printer user's guide for details.
- Make prints at an SD/SDHC Card-capable KODAK Picture Kiosk. (Visit [www.kodak.com/go/picturemaker](http://www.kodak.com/go/picturemaker).)
- Take the card to your local photo retailer for professional printing.



## Tagging your pictures

You can tag your pictures so they are easy to:

- Print
- Email
- Organize with a favorite tag
- Organize with a tag name that you create

## Tagging pictures for printing

- 1 Press the Review  button. Press  to locate a picture.
- 2 Press the Menu  button. Press  to highlight Print, then press OK.
- 3 Press  to select the number of copies.

**Optional:** You can apply a print quantity to other pictures. Press  for previous/next. Keep the print quantity as is, or press  to change it. Repeat this step until the desired print quantity is applied to the pictures.

- 4 Press OK.

*The Print icon appears in the status area.*

- Press the Shutter button halfway down to return to Capture mode.





**IMPORTANT:** *Your camera offers a built-in Help system. See [page 60](#).*

## Printing tagged pictures

When you transfer the tagged pictures to your computer, the EASYSHARE Software print screen opens. For details on printing, see Help in EASYSHARE Software.

## Tagging pictures/videos for emailing

It's simple to tag pictures so that they're ready to email using KODAK EASYSHARE Software. First, create a new email address. (See [Add a new email address or tag name](#).)

- 1 Press the Review  button. Press  to locate a picture, then press OK.
- 2 Press  to highlight Email, then press OK.
- 3 Press  to locate an email address, then press OK.

To tag other pictures/videos with the same address, scroll through them. When the picture you want is displayed, press OK.





To send the pictures/videos to more than one address, repeat step 3.

- To remove a selection, highlight a checked address and press OK. To remove all email selections, highlight Clear All, then press OK.
- Press the Shutter button halfway down to return to Capture mode.

*The Email icon appears in the status area.*

When you transfer the tagged pictures/videos to your computer, EASYSHARE Software prompts you to send the pictures/videos. For details, see Help in EASYSHARE Software.



## Add a new email address or tag name

- 1 Press the Review  button, then the Menu  button.
- 2 Press  to highlight Email or Tag, then press OK.
- 3 Press  to highlight New Email or New Tag, then press OK.
- 4 Use the on-camera keyboard, then press OK.

*The email address or tag name is now available.*

## Assigning the favorite tag to pictures/videos



To make your favorite pictures/videos easier to locate in EASYSHARE Software, you can assign the favorite tag.

- 1 Press the Review  button, then  to locate a picture/video.
- 2 Press the Share button.

*The favorite tag appears with the picture. When you transfer the tagged pictures/videos to your computer, EASYSHARE Software opens and categorizes your pictures/videos with a 5-star rating tag. (To configure the Share button in different ways [see page 43.](#))*

## Assigning other tags to pictures/videos

First, create a new tag name ([see page 52](#)).

- 1 Press the Review  button, then locate a picture/video.
- 2 Press the Menu  button.
- 3 Highlight Tag, then press OK.
- 4 Highlight a tag name, then press OK.

To assign the tag to other pictures, press  to locate a picture, then press OK.

*The tag name appears with the picture.*



To remove a selection, highlight a tag name and press OK. To remove all tag selections, highlight Clear All, then press OK.

When you transfer the tagged pictures/videos to your computer, EASYSHARE Software opens and categorizes your pictures/videos with the appropriate tag.

**IMPORTANT:** *Your camera offers a built-in Help system. [See page 60.](#)*

## Assigning a tag to the pictures/videos you take next

Use the Set Tag feature to assign a tag name to the next pictures/videos you take. First, create a new tag name (see page 52).

- 1 Press the Menu  button.
- 2 Highlight the Setup tab.
- 3 Highlight Set Tag, then press OK.
- 4 Highlight a tag name, then press OK.
- 5 Press the Menu  button to exit the menu.

*The selected tag is displayed on the LCD or EVF. The tag is applied to new pictures/videos.*

When you transfer the tagged pictures/videos to your computer, EASYSHARE Software opens and categorizes your pictures/videos with the appropriate tag.

**IMPORTANT:** *Your camera offers a built-in Help system. See page 60.*

# 6

## Troubleshooting

For step-by-step product support, visit [www.kodak.com/go/z980support](http://www.kodak.com/go/z980support) and select Step-by-Step Solutions and Repair.

### Camera problems

If	Try one or more of the following
Shutter button does not work.	<ul style="list-style-type: none"><li>■ Turn on the camera (<a href="#">see page 2</a>).</li><li>■ If the Portrait switch is in the Portrait position, only the Portrait Shutter button works. <a href="#">See page 4</a>.</li><li>■ Transfer pictures to the computer (<a href="#">see page 48</a>), delete pictures from the camera (<a href="#">see page 24</a>), switch image storage locations (<a href="#">see page 44</a>), or insert a card with available memory (<a href="#">see page 5</a>).</li></ul>
Camera does not turn on.	<ul style="list-style-type: none"><li>■ Install new batteries (<a href="#">see page 1</a>).</li><li>■ Charge rechargeable batteries.</li></ul>
Camera does not turn off.	<ul style="list-style-type: none"><li>■ Remove the battery, then reinsert or replace it. If the camera still does not function, visit <a href="http://www.kodak.com/go/z980support">www.kodak.com/go/z980support</a> and select Step-by-Step Solutions and Repair.</li></ul>
Pictures remaining number does not decrease after taking a picture.	<ul style="list-style-type: none"><li>■ The camera is operating normally. Continue taking pictures.</li></ul>
Stored pictures are corrupted.	<ul style="list-style-type: none"><li>■ Transfer the pictures to the computer (<a href="#">see page 48</a>), then format the card or internal memory (<a href="#">see page 46</a>).</li></ul> <p><b>CAUTION: Formatting a card deletes all pictures and videos, including protected files.</b></p> <ul style="list-style-type: none"><li>■ Retake pictures. Do not insert/remove card while the camera is on. Keep rechargeable batteries charged.</li></ul>

If	Try one or more of the following
In Review mode, you do not see a picture (or the expected picture) on the LCD or EVF.	<ul style="list-style-type: none"><li>■ Check the image storage location setting (<a href="#">page 44</a>).</li></ul>
In Review mode, a blue or black screen is displayed instead of a picture.	<ul style="list-style-type: none"><li>■ Transfer the picture to the computer (<a href="#">see page 48</a>), then format the card or internal memory (<a href="#">see page 46</a>).</li></ul> <p><b>CAUTION: Formatting a card deletes all pictures and videos, including protected files.</b></p>
Slide show does not run on external video device.	<ul style="list-style-type: none"><li>■ Check the cable connections.</li><li>■ Adjust the camera Video Out setting (NTSC or PAL, <a href="#">see page 45</a>).</li><li>■ See the external device's user's guide.</li></ul>
Picture is too light.	<ul style="list-style-type: none"><li>■ Turn off the flash, or move so there is at least 2 ft (0.6 m) between the camera and the subject.</li><li>■ Decrease Exposure Compensation (<a href="#">see page 21</a>).</li></ul>
Picture is not clear.	<ul style="list-style-type: none"><li>■ Clean the lens (<a href="#">see page 68</a>).</li><li>■ Make sure your camera is not in Close-up mode.</li><li>■ Move so there is at least 2 ft (0.6 m) between the camera and the subject.</li><li>■ Press the shutter button halfway to focus and set exposure. When the framing brackets turns green, press the Shutter button completely down.</li><li>■ Place the camera on a flat, steady surface or use a tripod.</li></ul>
Picture is too dark.	<ul style="list-style-type: none"><li>■ Turn on the flash (<a href="#">see page 14</a>).</li><li>■ Move so there is no more than 11.8 ft (3.6 m) in wide angle and 6.9 ft (2.1 m) in telephoto between the camera and the subject.</li><li>■ Use Fill flash (<a href="#">see page 14</a>) or change your position so light is not behind the subject.</li><li>■ Increase Exposure Compensation (<a href="#">see page 21</a>).</li></ul>

If	Try one or more of the following
Camera does not recognize SD/SDHC Card.	<ul style="list-style-type: none"> <li>■ Purchase a certified SD/SDHC Card.</li> <li>■ Format the card (<a href="#">see page 46</a>).</li> </ul> <p><b>CAUTION: Formatting a card deletes all pictures and videos, including protected files.</b></p> <ul style="list-style-type: none"> <li>■ Insert a card into the slot, then push to seat (<a href="#">see page 5</a>).</li> </ul>
Camera freezes up when a card is inserted or removed.	<ul style="list-style-type: none"> <li>■ Turn the camera off, then back on. Make sure the camera is turned off before inserting or removing a card.</li> </ul>
Memory card full.	<ul style="list-style-type: none"> <li>■ Insert a new card (<a href="#">see page 5</a>), transfer pictures to the computer (<a href="#">see page 48</a>), or delete pictures (<a href="#">see page 24</a>).</li> </ul>
Memory card and internal memory full.	<ul style="list-style-type: none"> <li>■ Transfer pictures to the computer (<a href="#">see page 48</a>), then format the card or internal memory (<a href="#">see page 46</a>).</li> </ul> <p><b>CAUTION: Formatting a card deletes all pictures and videos, including protected files.</b></p>
The Reset Camera feature did not take effect.	<ul style="list-style-type: none"> <li>■ After using the Reset Camera feature (<a href="#">see page 45</a>), turn the camera off and then on again.</li> </ul>
Pictures taken on a tripod are blurry.	<ul style="list-style-type: none"> <li>■ Occasionally, a tripod interferes with the camera's image stabilizer. In the Setup menu, set Image Stabilizer to Off (<a href="#">see page 44</a>).</li> </ul>
Cannot delete some pictures.	<ul style="list-style-type: none"> <li>■ If a picture is tagged as a Favorite, a Protect tag is automatically applied (and remains even if the Favorite tag is removed). A protected picture cannot be deleted unless the Protect tag is removed (<a href="#">see page 25</a>) or the card/internal memory is formatted (<a href="#">see page 46</a>).</li> </ul>
Pictures that have KODAK PERFECT TOUCH Technology applied (twice) are of lower image quality.	<ul style="list-style-type: none"> <li>■ If PERFECT TOUCH Technology has been applied to a picture on the camera, do not apply it again when the picture is on the computer (or on a KODAK Picture Kiosk).</li> </ul> <p>NOTE: PERFECT TOUCH Technology is automatically applied to pictures taken in Smart Capture mode.</p>

## Camera/computer communications

If	Try one or more of the following
Cannot transfer pictures. (The Add New Hardware Wizard cannot locate drivers.)	■ Disconnect the USB cable. Close all open applications. Re-install the software (see page 47).
The computer does not communicate with the camera.	■ Turn on the camera (see page 2). ■ Install new batteries (see page 1) or charge rechargeable batteries. ■ Connect the USB cable to camera and computer port (see page 48). ■ Install the software (see page 47). ■ Disconnect the USB cable. Close all open applications. Re-install the software (see page 47). ■ Disconnect camera from the computer. Close all software applications, reconnect camera.
Pictures taken in Smart Capture with Orientation Sensor set to "On Transfer" are not correctly rotated when transferred to the computer.	■ In the Setup menu, change the Orientation Sensor setting to "On" (see page 45). Then, take new pictures and transfer them to the computer.
HD videos longer than 20 minutes are not transferred to the computer.	■ Use a card reader to drag and drop long videos to the computer. Then use the Add Pictures button in EASYSHARE Software to import the videos. ■ Take shorter videos.
Tags that are assigned to a video do not transfer to the computer.	■ After a picture/video is transferred to the computer, assign tags using EASYSHARE Software.
Email tags are not transferred to the computer, or email address are deleted from the camera.	■ After a picture/video is transferred to the computer, assign email tags using EASYSHARE Software.
Sound tags are not transferred to the computer with pictures.	■ Assign a Sound tag to pictures taken in any mode except Smart Capture.

## LCD/EVF messages

If	Try one or more of the following
No images to display	■ Change image storage location setting ( <a href="#">see page 44</a> ).
Memory card requires formatting	■ Insert a new card ( <a href="#">see page 5</a> ) or format the card ( <a href="#">see page 46</a> ). <b>CAUTION: Formatting a card deletes all pictures and videos, including protected files.</b>
Memory card cannot be read (Please format memory card or insert another card)	
Internal memory requires formatting	■ Format the internal memory ( <a href="#">see page 46</a> ). <b>CAUTION: Formatting a card deletes all pictures and videos, including protected files.</b>
Internal memory cannot be read (Please format internal memory)	
Memory card is locked (Insert new memory card)	■ Insert a new card ( <a href="#">see page 5</a> ), move the switch on the card to unlock the card, or change the image storage location to internal memory ( <a href="#">see page 44</a> ).
Memory card is unusable (Insert new memory card)	■ Insert a new card ( <a href="#">see page 5</a> ) or format the card ( <a href="#">see page 46</a> ). <b>CAUTION: Formatting a card deletes all pictures and videos, including protected files.</b>
High camera temperature. (Camera will be turned off.)	■ Leave the camera off for ten minutes, then turn it back on. If the message reappears, visit <a href="http://www.kodak.com/go/z980support">www.kodak.com/go/z980support</a> and select Step-by-Step Solutions and Repair.
Unrecognized file format	■ Transfer the picture to the computer ( <a href="#">see page 48</a> ), or delete it ( <a href="#">see page 24</a> ).
Camera error #XXXX.	■ Turn camera off, then back on. If the message reappears, visit <a href="http://www.kodak.com/go/z980support">www.kodak.com/go/z980support</a> and select Step-by-Step Solutions and Repair.

# 7

## Getting help

### Getting help from your camera

You want the most from your camera. You want to understand:

- What it can do for you
- And how to take the best possible pictures and videos

### Great news!

Your camera offers a built-in Help system. It describes every setting for every menu choice. If you learn nothing else about your camera, learn how to use on-camera Help. Because the more you know your camera, the more confident you become!

### Turning on camera Help



1 Press the Menu button, then highlight a menu choice.

2 Press the Info **i** button.

▲/▼ Scroll through a Help topic

---

## Helpful links

### Camera

---

Email, write, or phone customer support	<a href="http://www.kodak.com/go/contact">www.kodak.com/go/contact</a>
Get support for your product (FAQs, arrange for repairs, troubleshooting information, etc.)	<a href="http://www.kodak.com/go/z980support">www.kodak.com/go/z980support</a>
Purchase camera accessories (lenses, cards, etc.)	<a href="http://www.kodak.com/go/z980accessories">www.kodak.com/go/z980accessories</a>
Download the latest camera firmware and software	<a href="http://www.kodak.com/go/z980downloads">www.kodak.com/go/z980downloads</a>
See online demonstrations of your camera	<a href="http://www.kodak.com/go/howto">www.kodak.com/go/howto</a>

---

### Software

---

Get information on EASYSHARE Software	<a href="http://www.kodak.com/go/easysharesw">www.kodak.com/go/easysharesw</a> (or click the Help button in EASYSHARE Software)
Get help with the WINDOWS Operating System and working with digital pictures	<a href="http://www.kodak.com/go/pcbasics">www.kodak.com/go/pcbasics</a>

---

### Other

---

Get support for other cameras, software, accessories	<a href="http://www.kodak.com/go/support">www.kodak.com/go/support</a>
Get information on KODAK Inkjet Products	<a href="http://www.kodak.com/go/inkjet">www.kodak.com/go/inkjet</a>
Register your camera	<a href="http://www.kodak.com/go/register">www.kodak.com/go/register</a>

---

## Getting help

---

NOTE: If you have questions concerning this product, you may speak with Kodak customer support.

Australia	1800 267 588	Netherlands	020 346 9372
Austria	0179 567 357	New Zealand	0800 880 120
Belgium	02 713 14 45	Norway	23 16 21 33
Brazil	0800 891 42 13	Philippines	1 800 1 888 9600
Canada	1 800 465 6325	Poland	00800 4411625
China	800 820 6027	Portugal	021 415 4125
Czech Republic	00 800 56325000	Russia	8 495 929 9166
Denmark	3 848 71 30	Singapore	800 6363 036
Finland	0800 1 17056	Slovakia	00 800 56325000
France	01 55 1740 77	Spain	91 749 76 53
Germany	069 5007 0035	Sweden	08 587 704 21
Greece	00800 44140775	Switzerland	044 838 53 51
Hong Kong	800 901 514	Taiwan	0800 096 868
Hungary	06 80 456 325	Thailand	001 800 631 0017
India	91 80 41374555 (toll free 000800 440 1227)	Turkey	00800 448827073
Ireland	01 407 3054	United Kingdom	0870 243 0270
Italy	02 696 33452	United States	1 800 235 6325
Japan	03 5540 9002	International Toll Line	+44 131 458 6714
Korea	080 708 5600	International Toll Fax	+44 131 458 6962

# 8

## Appendix

### Camera specifications

For more specifications, visit [www.kodak.com/go/z980support](http://www.kodak.com/go/z980support).

**CCD**—1/2.3-type (4:3 aspect ratio)

**Effective Pixels**—4112 x 3032 (12 MP)

**Lens**—24X optical zoom lens, 26–624 mm (35 mm equivalent); f/2.8–f/8.0

**Image stabilizer**—CCD-shift

**Lens barrier**—Automatic built-in

**Digital zoom**—5.0X continuous

**Combined zoom**—120X

**Shutter speed**—Smart Capture: 1/2–1/2000 sec.; P, A, S, M: 16–1/2000 sec.

**Color display**—7.6 cm (3 in.) color hybrid LCD; 230 K (960 x 240) dots; 30 fps

**External storage**—Optional SD/SDHC Card . (The SD logo is a trademark of the SD Card Association.)

**Internal storage**—64 MB (47.5 MB available for image storage. 1 MB equals one million bytes.)

**Focus system**—TTL-AF (through-the-lens auto focus); Multi-zone AF, and Center-zone AF; Working range:

0.7 m (2.3 ft)—infinity @ wide

2.5 m (8.2 ft)—infinity @ telephoto

0.1–1.0 m (0.3–3.3 ft) @ wide macro

1.7–3.0 m (5.6–9.8 ft) @ telephoto macro

**ISO speed**—Smart Capture mode: Auto, ISO 64–1600

P mode: Auto: 64–400; Manual: 64, 100, 200, 400, 800, 1600, 3200, 6400 (3200 and 6400 available at 3.1 MP and lower.)

A, S, M modes: ISO 64, 100, 200, 400, 800, 1600, 3200, 6400 (3200 and 6400 available at 3.1 MP and lower.)

**Exposure metering**—TTL-AE; Multi-pattern, Center-weighted, Center spot

**Exposure compensation**—+/-2.0 EV with 1/3 EV steps

**Exposure bracketing**—3 images with selectable +/- 0.3 EV steps

**White balance**—Auto, Daylight, Tungsten, Fluorescent, Open Shade

**Built-in Electronic flash**—Auto flash; Guide no. 9.0 @ ISO 100; working range in Smart Capture mode: 6.2 m (20.3 ft) @ wide; 3.5 m (11.5 ft) @ telephoto

**Flash modes**—Auto, Fill, Red-eye Reduction, Off

**Capture modes**—Smart Capture, Portrait, Sport, SCN Modes, Program, Aperture Priority, Shutter Priority, Manual, Panorama, Video

**Drive modes**—Single shot, Burst, High-speed Burst, Self-timer (10-second, 2-shot, and 2-second)

**File format**—Still: JPEG/EXIF 2.21; Video: MPEG-4 (H264); Audio: AAC

**Color modes**—High Color, Natural Color, Low Color, Black & White, Sepia

**Sharpness**—Sharp, Normal, Soft

**Video size**—HD (1280 x 720 @ 30 fps); VGA (640 x 480 @ 30 fps); QVGA (320 x 240 @ 30 fps)

**Video output**—NTSC or PAL selectable

**Power**—4 KODAK Ni-MH Pre-Charged Rechargeable Batteries AA; KODAK 5-Volt AC Adapter

**Burst mode**—Burst: maximum 6 pictures @ 1 fps; High-speed burst: maximum 9 pictures @ 5 fps; Auto Exposure, Auto Focus, Auto White Balance executed for first shot only

**Self-timer**—2 seconds, 10 seconds, or 2-shot

**Microphones**—Stereo

**Speaker**—

**Output image size—Smart Capture mode**

12 MP (4:3): 4000 x 3000 pixels

10.7 MP (3:2): 4000 x 2664 pixels

9.0 MP (16:9): 4000 x 2256 pixels

6.0 MP (4:3): 2832 x 2128 pixels

3.1 MP (4:3): 2048 x 1536 pixels

2.2 MP (3:2): 1800 x 1200 pixels

2.1 MP (16:9): 1920 x 1080 pixels

1.2 MP (4:3): 1280 x 960 pixels

**Communication with computer**—USB 2.0 high speed (PIMA 15740 protocol) via USB cable model U-8

**PICTBRIDGE Technology compatibility**—Yes

**Auto power off**—Selectable 1, 3, 5, 10 minutes

**Sound tag**—Yes

**Date stamp**—Yes

**Tripod mount**—1/4 inch

**Size**—123.7 x 90.5 x 105 mm (4.9 x 3.6 x 4.1 in.) @ power off

**Weight**—415 g (14.6 oz) without battery or card

**Operating temperature**—32–104°F (0–40°C)



























