

OLYMPUS[®]

CAMEDIA

DIGITAL CAMERA

C-765 Ultra Zoom

REFERENCE MANUAL

<Click Here>

CAMERA OPERATION MANUAL

Explanation of digital camera functions and operating instructions.

**DIGITAL CAMERA - PC CONNECTION
OPERATION MANUAL**

Explanation of how to download images between your digital camera and PC.

OLYMPUS®

CAMEDIA
DIGITAL CAMERA

C-765 Ultra Zoom

REFERENCE MANUAL

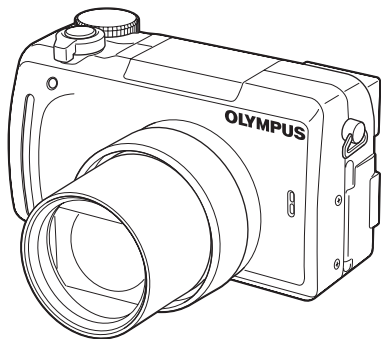

-
- Thank you for purchasing an Olympus digital camera. Before you start to use your new camera, please read these instructions carefully to enjoy optimum performance and a longer service life. Keep this manual in a safe place for future reference.
 - We recommend that you take test shots to get accustomed to your camera before taking important photographs.
 - In the interest of continually improving products, Olympus reserves the right to update or modify information contained in this manual.

For customers in North and South America

For customers in USA

Declaration of Conformity

Model Number : C-765 Ultra Zoom

Trade Name : OLYMPUS

Responsible Party : Olympus America Inc.

Address : 2 Corporate Center Drive, Melville, New York

11747-3157 U.S.A.

Telephone Number : 1-631-844-5000

Tested To Comply With FCC Standards

FOR HOME OR OFFICE USE

This device complies with Part 15 of the FCC rules. Operation is subject to the following two conditions:

- (1) This device may not cause harmful interference.
- (2) This device must accept any interference received, including interference that may cause undesired operation.

For customers in Canada

This Class B digital apparatus meets all requirements of the Canadian Interference-Causing Equipment Regulations.

For customers in Europe



"CE" mark indicates that this product complies with the European requirements for safety, health, environment and customer protection.

"CE" mark cameras are intended for sales in Europe.

Trademarks

- IBM is a registered trademark of International Business Machines Corporation.
- Microsoft and Windows are registered trademarks of Microsoft Corporation.
- Macintosh is a trademark of Apple Computer Inc.
- All other company and product names are registered trademarks and/or trademarks of their respective owners.
- The standards for camera file systems referred to in this manual are the "Design Rule for Camera File System/DCF" standards stipulated by the Japan Electronics and Information Technology Industries Association (JEITA).



Composition of the manual

	Contents	P.4	
	Names of parts	P.10	
Introduction of the camera's functions	Getting started	P.17	1
	Using the menus	P.32	2
Basic Photography	Shooting basics	P.43	3
Advanced Photography To get that particular shot using various effects or for fine-tuning the settings.	Flash	P.57	4
	Advanced shooting	P.65	5
	Adjusting the image quality and exposure	P.96	6
For playing back and editing pictures	Playback	P.113	7
Settings that make the camera easier to operate.	Useful functions	P.135	8
Printing pictures	Print setting (DPOF)	P.158	9
	Direct printing (PictBridge)	P.169	10
Troubleshooting and other information	Miscellaneous	P.186	11
	Specifications	P.207	
	Glossary of terms	P.209	
	Index	P.212	

Contents

Composition of the manual	3
Names of parts	10
Camera	10
Viewfinder and monitor indications	12
Memory gauge	15
Battery check	15
How to use this manual	16

1 Getting started 17

Attaching the strap	17
Battery/card basics	18
Charging the battery	18
Card basics	19
Inserting and removing the battery and card	20
Using an AC adapter (optional)	23
Power on/off	24
Startup/Shutdown screen	25
If the card is not recognized (card check)	25
Selecting a language 	26
Setting the date and time 	28
Adjusting the viewfinder	30
Holding the camera	31

2 Using the menus 32



About the menus	32
How to use the menus	33
Shortcut menus	35
Mode Menus	38

3 Shooting basics 43





Shooting modes	43
Taking still pictures	47









If correct focus cannot be obtained	50
Using the Focus Lock function	50
Subjects that are difficult to focus on	51
Recording movies 	52
Zoom	54
Using the optical zoom	54
SUPER ZOOM – Using the super zoom	55
DIGITAL ZOOM - Using the digital zoom	56

4 Flash 57









Flash shooting 	57
Using the slow synchronization flash  SLOW	63
Flash intensity control 	64

5 Advanced shooting 65



A/S/M mode A/S/M	65
Aperture priority shooting A	66
Shutter priority shooting S	67
Manual shooting M	68
Using My Mode 	69
Focusing applications	70
AF MODE – Changing the focus range.	70
FULLTIME AF – A reliable time-saving way to focus	71
AF AREA – Changing the position of the AF target mark	72
AF LOCK – Locking the focus.	73
Manual focus.	75
Metering 	77
Spot metering	77
MULTI METERING	78
AE LOCK – Locking the exposure AEL	80
Macro mode shooting 	82
Super macro mode shooting 	83
Self-timer shooting 	84











Sequential shooting  HI  AF  BKT	85
Sequential shooting, high speed sequential shooting and AF sequential shooting  HI  AF	85
Auto bracketing BKT	86
Self-portrait shooting 	88
PANORAMA - Panorama shooting	89
2 IN 1 - Taking two-in-one pictures 2 IN 1	91
FUNCTION - Adding special effects to pictures	93
Recording sound with still pictures 	94
Recording sound with movies 	95

6 Adjusting the image quality and exposure 96

Record mode 	96
3:2 Resolution	97
ENLARGE SIZE	97
Selecting a record mode	99
ISO sensitivity	101
Exposure compensation 	102
White balance WB	103
Auto white balance	103
Preset white balance	104
One-touch white balance 	104
White balance adjustment 	106
SHARPNESS 	107
CONTRAST 	108
SATURATION 	109
NOISE REDUCTION NR	110
Histogram display 	111





7 Playback 113

Viewing still pictures 	113
QUICK VIEW	114
Close-up playback 	115

Index display 	116
Selecting the number of pictures	117
Slideshow 	118
Viewing movies 	119
Editing movies	121
INDEX - Creating an index	121
EDIT - Editing a movie	123
Playback on a TV	125
Picture rotation 	126
Recording sound 	127
Editing still pictures	128
Resizing 	128
Trimming 	129
Protecting pictures 	131
SWITCH FRAME – Playing back only protected pictures	132
Erasing pictures 	133
Single-frame erase 	133
All-frame erase 	134





8 Useful functions

135

ALL RESET - Saving the camera's settings	135
CUSTOM BUTTON 	137
Setting the custom button	138
Using the custom button	139
SHORT CUT	140
Setting the shortcut menu	141
Using the shortcut menu	142
MY MODE SETUP 	143
CARD SETUP – Formatting cards 	146
Information display INFO	148
Monitor/viewfinder brightness adjustment 	149
REC VIEW	150
SLEEP - Sleep Timer	151
Beep 	152

POWER ON/OFF SETUP – Power on/off display setting . . .	152
SCREEN SETUP	153
FILE NAME	154
PIXEL MAPPING	155
Measurement units m/ft	156
VIDEO OUT – Video output selection	157

9 Print setting (DPOF) 158

How to print pictures 	158
All-frame reservation 	160
Single-frame reservation 	162
Trimming 	165
Resetting print reservation data 	167

10 Direct printing (PictBridge) 169



Using the direct printing function	169
Connecting the camera to a printer	170
Printing pictures	171
Easy printing	172
PRINT mode/MULTI PRINT mode	174
ALL PRINT mode	178
ALL INDEX mode/PRINT ORDER mode	180
Trim the picture	182
Exiting direct printing	184
If an error code is displayed	185

11 Miscellaneous 186

Error codes	186
Troubleshooting	187
List of menus	194
List of factory default settings	200
Modes and Shooting Functions	203

Camera maintenance	206
Specifications	207
Glossary of terms	209
Index	212

Indications used in this manual

 Note	Important information on factors which may lead to a malfunction or operational problems. Also warns of operations that should be absolutely avoided.
	Useful information and hints that will help you get the most out of your camera.
	Reference pages describing details or associated information.

Names of parts

Camera

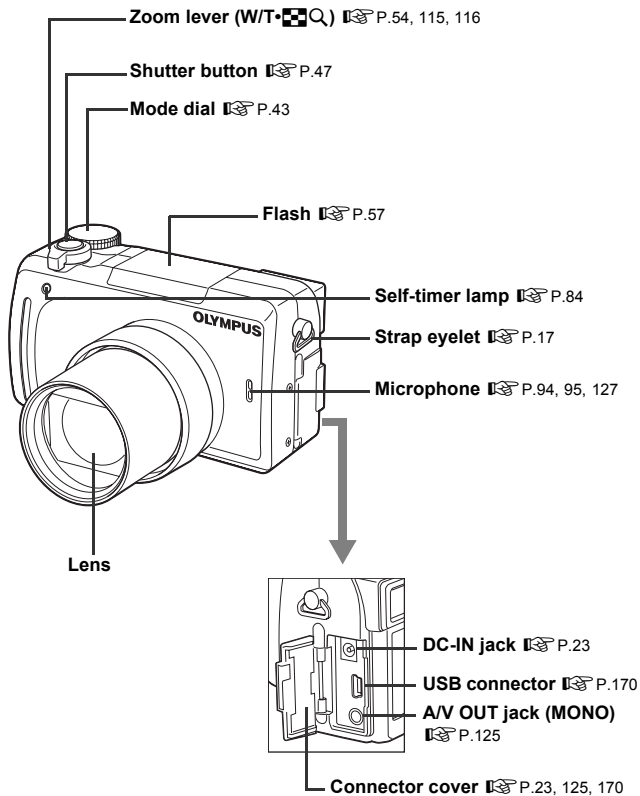

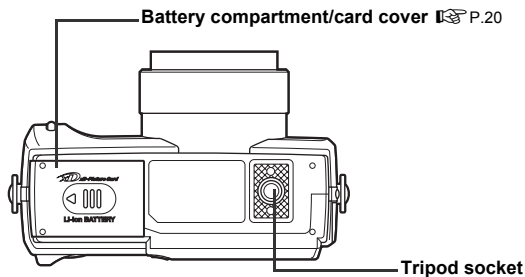
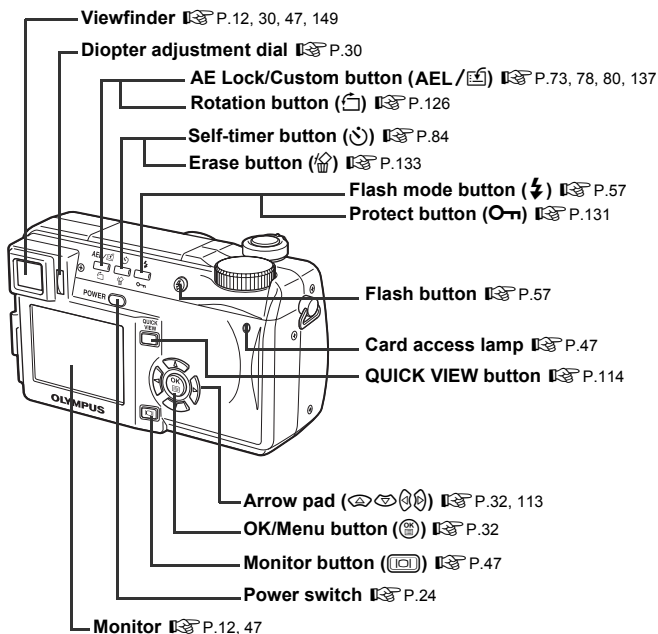









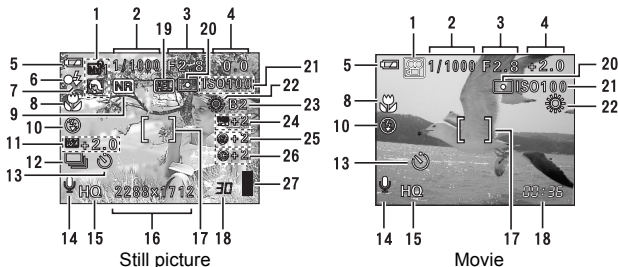









Viewfinder and monitor indications











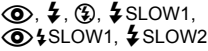

INFO setting allows you to select how much information to display on the screen. Screens with the Information display set to ON are shown below.

 “Information display” (P.148)

● Shooting modes



Item	Indications	Ref. Page
1 Shooting modes	P, A, S, M ,  ,  ,  ,  ,  ,  ,  ,  ,  , 	P.43
2 Shutter speed	15" – 1/1000	P.67
3 Aperture value	F2.8 – F8.0	P.66
4 Exposure compensation Exposure differential	-2.0 – +2.0 -3.0 – +3.0	P.102 P.68
5 Battery check	 , 	P.15
6 Green lamp		P.48
7 Flash stand-by Camera movement warning/Flash charge	 (Lights)  (Blinks)	P.59
8 Macro mode Super macro mode Manual focus	  MF	P.82 P.83 P.75
9 Noise reduction	NR	P.110

	Item	Indications	Ref. Page
10	Flash mode		P.57
11	Flash intensity control	 -2.0 – +2.0	P.64
12	Drive		P.85
13	Self-timer		P.84
14	Sound record		P.94, 95, 127
15	Record mode	TIFF, SHQ, HQ, SQ1, SQ2	P.96
16	Resolution	2288 × 1712, 1280 × 960, 640 × 480 etc.	P.98
17	AF target mark	[]	P.47
18	Number of storable still pictures	30	P.98
	Time remaining	00:36	P.52
19	AE lock		P.80
	AE memory		
20	Spot metering		P.77
21	ISO	ISO 64, ISO 100, ISO 200, ISO 400	P.101
22	White Balance		P.103
23	White balance adjustment	B1 – B7, R1 – R7	P.106
24	Saturation	 -5 – +5	P.109
25	Sharpness	 : -5 – +5	P.107
26	Contrast	 : -5 – +5	P.108
27	Memory gauge		P.15

● Playback mode

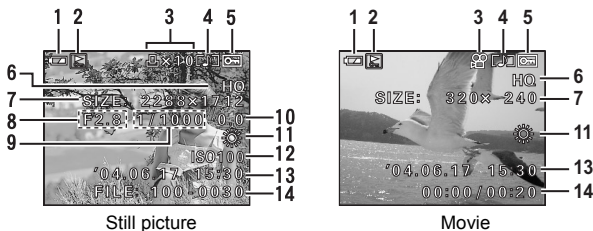

Still picture

Movie

	Item	Indications	Ref. Page
1	Battery check		P.15
2	Switch frame		P.132
3	Print reservation, Number of prints Movie	× 10 	P.160 P.119
4	Sound record		P.94
5	Protect		P.131
6	Record mode	TIFF, SHQ, HQ, SQ1, SQ2	P.96
7	Resolution	2288 × 1712, 1280 × 960, 640 × 480, 320 × 240 etc.	P.98
8	Aperture value	F2.8 – F8.0	P.66
9	Shutter speed	15" – 1/1000	P.67
10	Exposure compensation	-2.0 – +2.0	P.102
11	White balance	WB AUTO,	P.103
12	ISO	ISO 64, ISO 100, ISO 200, ISO 400	P.101
13	Date and time	'04.06.17 15:30	P.28
14	File number, Frame number Playing time/ Total recording time	FILE : 100 – 0030, 30 00:00/00:20	P.154



Note

- The indications that appear on a movie picture that has been selected and displayed from the index display are different from those that appear when the movie picture is displayed using the movie playback function.

●Memory gauge

The memory gauge lights up when you take a still picture. While the gauge is lit, the camera is storing the picture on the card. The memory gauge indication changes as shown below depending on the shooting status. The indication is not displayed during movie recording.

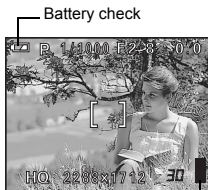

Memory gauge

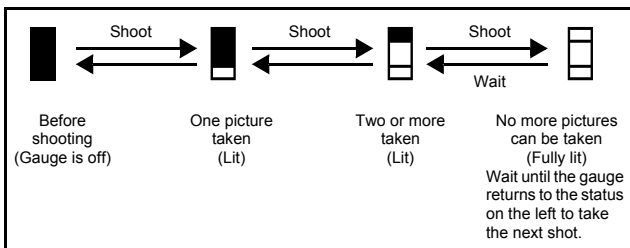

●Battery check

If the remaining battery power is low, the battery check indication changes as follows when the camera is turned on or while the camera is in use.

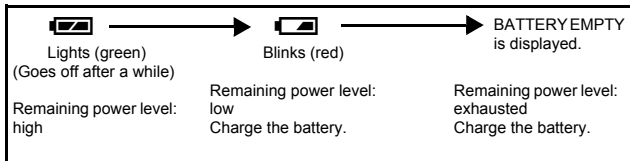

How to use this manual

Set the mode dial to any of the marks shown here.

Follow the arrows to perform menu operations.

For details on operating procedures, see "How to use the menus" (P.33).

SHARPNESS

This function adjusts the sharpness of the image.

Mode dial

- 1 In the top menu, select **MODE MENU** → **PICTURE** → **SHARPNESS**, and press .

See "How to use the menus" (P.33)



Arrow pad
OK button



- 2 Press   to adjust the sharpness between **+5** and **-5**.

• To increase the sharpness (+):

Press . The image contours are emphasized, making the image appear sharper and more vivid. Use this setting when you want to print pictures.

• To reduce the sharpness (-):

Press . The image contours are softened. Use this setting when you want to edit images on a PC.

• When you have finished setting the sharpness, press . Press  again to exit the menu.

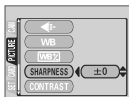

6

Adjusting the image quality

This represents the arrow pad. Only arrows applicable to the operation are shown.

This sample page is only for your reference. It may differ from the actual page in this manual.

1 Getting started

Attaching the strap

- 1 Pass the lens cap string through the hole in the lens cap, then pass the other end through the loop and pull tight.
- 2 Pull the ends of the strap out of the stopper and ring.
- 3 Thread one end of the strap (A) through the string loop (attached to the lens cap in step 1). Then thread it through the strap eyelet on the camera.
- 4 Thread the end of the strap back through the ring and stopper as indicated by the arrows. Adjust the strap to the desired length.
- 5 Thread the end of the strap again through the stopper as indicated by the arrow. Pull the strap through the stopper (B) to make sure it is fastened securely.
- 6 Attach the strap to the other eyelet following steps 3 to 5.

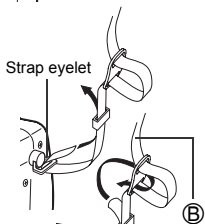
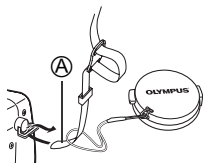
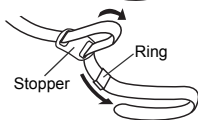
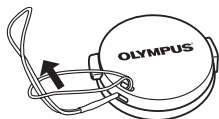

1

Getting started



Note

- Be careful with the strap when you carry the camera, as it can easily catch on stray objects, causing injury or damage.
- Attach the strap correctly as shown above so that the camera does not fall off. If the strap is attached incorrectly and the camera falls off, Olympus is not responsible for any damages.

Battery/card basics

Charging the battery

This camera uses an Olympus lithium-ion battery (LI-10B). Other types of batteries cannot be used.

The battery is not fully charged at the time of purchase. Be sure to use the specified battery charger (LI-10C) to charge the battery before use. For more information, read the manual supplied with the battery charger.

1
Getting started

- 1 **Connect the power cord to the power connector on the battery charger.**

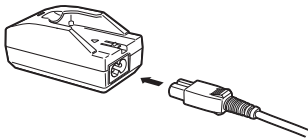

- 2 **Plug the power cord into an AC wall outlet.**

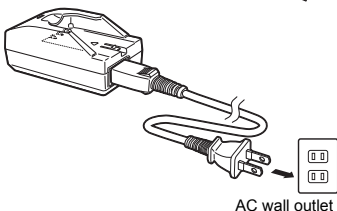

- 3 **Insert the battery into the battery charger while aligning the \oplus \ominus marks on both the battery and battery charger.**

- The charging indicator lights red and charging begins.
- When charging is complete, the indicator lights green.

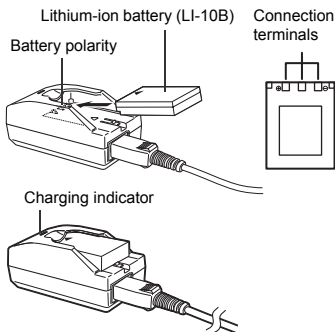



Note

- Charging of the battery usually takes 2 hours. Charging may be completed quickly depending on how much battery power remains.
- Do not use a battery charger other than the specified battery charger.
- If the charging indicator blinks red, this may indicate that the battery is not properly attached or that the battery has malfunctioned.
- Charging of the battery may cause noise on a television or radio sharing the same wall outlet; however, this is not a malfunction. If this should happen, plug the battery charger into a separate wall outlet.
- The battery may become hot during charging; however, this does not indicate a malfunction.
- This battery charger is guaranteed to operate within an ambient temperature range of 0°C to 40°C. To ensure maximum performance of the battery charger, however, you are recommended to use it between 10°C and 30°C.
- When using the battery charger in a foreign country, be sure to use a travel converter that matches the wall outlet in the area the camera is being used. Please consult a travel agency for more information on travel converters.

Card basics

“Card” in this manual refers to the xD-Picture Card. The camera uses the card to record pictures.

The card corresponds to normal camera film for recording the pictures you have taken. Pictures recorded and stored on the card can easily be erased, overwritten, and/or edited on a PC.

- ① Index area
You can write down the card's contents.
- ② Contact area
Comes into contact with the camera's signal read contacts.



Compatible cards

- xD-Picture Card (16 to 512 MB)



Note

- This camera may not recognize a non-Olympus card or a card that was formatted on another device (such as a PC, etc.). Before use, be sure to format the card on this camera.  “CARD SETUP – Formatting cards” (P.146)

Inserting and removing the battery and card

1 Make sure the camera is turned off.

- The monitor is off.
- The viewfinder is off.
- The lens is not extended.

2 Slide the battery compartment/card cover in the direction of (A), then lift in the direction of (B).

- Use the ball of your finger to slide the cover. Do not use your fingernail as this could result in injury.

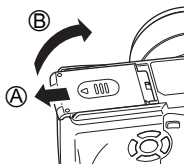

3 Loading the battery

Align the battery as shown and insert it into the battery compartment until the battery is locked in position with the battery lock knob.

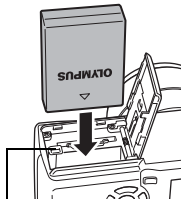

Battery lock knob

Removing the battery

Slide the knob in the direction of the arrow. When the battery is ejected, pull it out of the battery compartment.

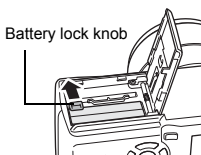

Battery lock knob

Low battery warning

The amount of power consumed varies considerably depending on the operations performed on the digital camera. If you use an exhausted battery, the camera may turn off without displaying the battery level warning (P.15).



Note

- The life of the battery may vary according to the shooting conditions, etc.
- The amount of power consumed by the camera varies considerably depending on shooting conditions, etc.
- Power is consumed continuously during the conditions described below. This discourages the power to last longer.
 - When the monitor is turned on.
 - When the monitor is in the playback mode for an extended period of time.
 - Repeated zoom adjustments.
 - Repeated auto-focus by depressing the shutter button halfway.
 - When the FULLTIME AF mode is turned on.
 - When connected to a computer or printer.
- If the camera is left for about 3 hours with the battery removed, some of the internal settings may revert to the factory default settings.

Inserting a card

Insert the card in the appropriate direction.

- Insert the card while keeping it straight.
- Inserting the card the wrong way or at an angle could damage the contact area or cause the card to jam.
- If the card is not inserted all the way, data may not be written to the card.

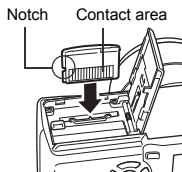

Removing the card

Push the card all the way in to unlock it, then let it return slowly.

- The card is ejected a short way and then stops. Hold the card straight and pull it out.

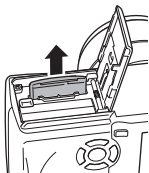
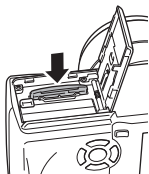

- 4 Close the battery compartment/card cover in direction © and then slide it in the direction shown ④.**

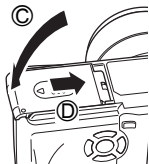
**Notes for removing the card**

Releasing your finger quickly after pushing the card all the way in may cause it to eject forcefully out of the slot.



Note

- Do not press on the card with hard or pointed items such as ballpoint pens.
- Never open the battery compartment/card cover, or remove the card or the battery while the camera is turned on. Doing so could destroy the data stored on the card. Once destroyed, data cannot be restored.
- Do not place a sticker or label on the card as this could prevent the card from being ejected.

Using an AC adapter (optional)

An AC adapter is useful for time-consuming tasks such as image downloads to a computer.

An optional Olympus CAMEDIA-brand AC adapter allows you to power your digital camera from a common AC wall outlet. Be sure to use the specified AC adapter.

Use an AC adapter designed to operate on the AC voltage in the area the camera is being used.

Consult your nearest Olympus dealer or Service center for details.

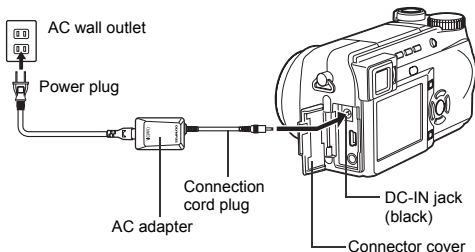

Note

- If the battery power runs out while the camera is connected to a computer or printer, the image data may be lost or damaged. It is recommended you use the AC adapter when connected to a computer or printer. Do not connect or disconnect the AC adapter while the camera is connected to a computer or printer.
- Do not remove or load the battery or connect or disconnect the AC adapter while the camera is turned on. Doing so could affect the camera's internal settings or functions.
- When using an AC adapter, power is supplied to the camera by the AC adapter even if the battery is loaded in the camera. The AC adapter does not charge the battery in the camera.

Power on/off

- 1 Press the tabs on the lens cap as indicated by the arrows and remove the lens cap.

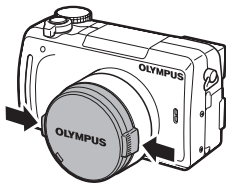

- 2 Press the power switch.

- The power turns on and the lens extends when the mode dial is set to any mode other than . The monitor turns on.
- When the mode dial is set to , the camera turns on in the playback mode and the monitor turns on.

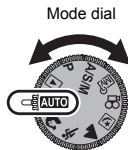

- 3 To turn the camera off, press the power switch again.

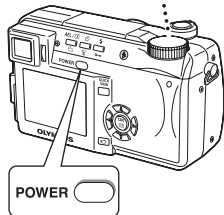

TIPS

- To save battery power, the camera automatically enters the sleep mode and stops the operation after about 3 minutes of non-operation. The camera activates again as soon as you operate the shutter button or zoom lever. The sleep time interval can be set in any shooting mode (except). "SLEEP - Sleep Timer" (P.151)



Note

- If the camera is subjected to strong vibrations or shocks while it is turned on, the camera may immediately turn off and reset the date and other settings.

Startup/Shutdown screen

This image is displayed on the monitor each time the camera is turned on or off. You can also use your favorite image (P.152).



Startup/Shutdown screen
(Factory default setting)

If the card is not recognized (card check)

When the power is turned on, the camera checks the card automatically. If there is no card in the camera or a card that is not supported by this camera is inserted, the following screen is displayed.

Monitor indication	Corrective action
<p>The screen shows a large exclamation mark icon above the text "NO CARD".</p>	<p>There is no card in the camera or the card is not inserted properly. → Insert a card. If a card is already inserted, remove it and insert it again correctly.</p>
<p>The top screen is titled "CARD SETUP" and has two buttons: "POWER OFF" and "FORMAT". The bottom screen is titled "FORMAT" and has a warning icon and the text "CAUTION ERASING ALL", with "YES" and "NO" buttons below it.</p>	<p>The card cannot record, play back or erase pictures. Format the card or replace it with a new one. → Press to select POWER OFF, then press . Replace the card with a new one. → Format the card. Press to select . Press to display the confirmation screen. Select YES and press . Formatting starts. If the card was successfully formatted, the camera is ready to take pictures.</p>



Note

All data stored on the card is erased when the card is formatted.

Selecting a language



You can select a language for on-screen display. This reference manual shows the English on-screen display in the illustrations and explanations. Available language vary depending on the area where you purchased this camera.

1

Getting started

- 1 Set the mode dial to **P** and press the power switch to turn the camera on.

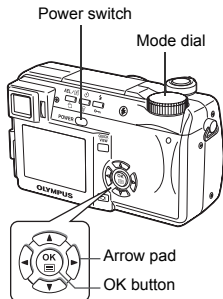

- 2 Press .
 - The top menu is displayed.
- 3 Press on the arrow pad to select **MODE MENU**.

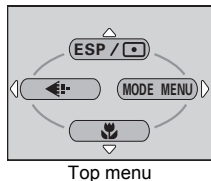

- 4 Press to select the **SETUP** tab, then press .

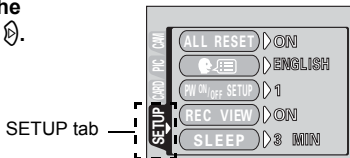

- 5 Press to select , then press .

- The green frame moves to the selected item.

- 6 Press to select a language, then press .

- 7 Press again to exit the menu.

- 8 To turn the camera off, press the power switch.

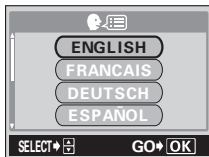

Power switch

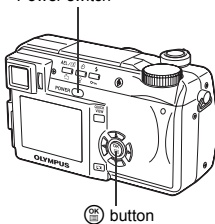

OK button

1

Getting started

Setting the date and time



- 1 Set the mode dial to **P** and press the power switch to turn the camera on.

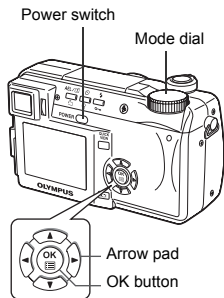

- 2 Press .
 - The top menu is displayed.
- 3 Press on the arrow pad to select **MODE MENU**.

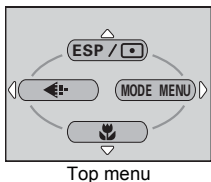

- 4 Press to select the **SETUP** tab, then press .

SETUP tab

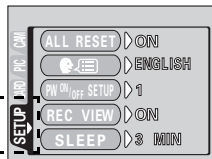

- 5 Press to select , then press .
- The green frame moves to the selected item.

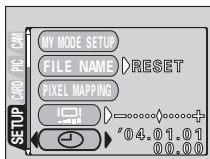

- 6** Press to select one of the following date formats: Y-M-D (Year/Month/Day), M-D-Y (Month/Day/Year), D-M-Y (Day/Month/Year). Then press .

- Move to the year setting.
- The following steps show the procedure used when the date and time settings are set to Y-M-D.

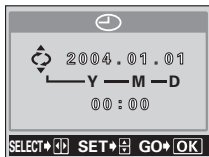

- 7** Press to set the year, then press to move to the month setting.

- To move back to the previous setting, press .
- The first two digits of the year are fixed.

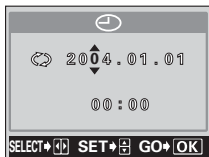

- 8** Repeat this procedure until the date and time are completely set.

- The time is displayed in the 24-hour format. Consequently, 2 p.m. is displayed as 14:00.

- 9** Press .

- For a more accurate setting, press when the time signal hits 00 seconds.

- 10** To turn the camera off, press the power switch.

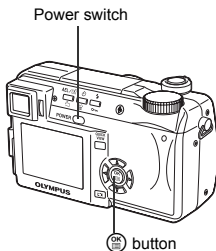

Note

- The date and time settings will be returned to the factory default settings if the camera is left without the battery for approximately one day. The settings will be canceled more quickly if the battery was only loaded in the camera for a short time before being removed. Before taking important pictures, check that the date and time settings are correct.

Adjusting the viewfinder

To make the camera easier to use, adjust the viewfinder to match the eyesight (visual acuity) of the person using the camera.

1 Getting started

- 1 Set the mode dial to **AUTO** and press the power switch.**
 - The camera and the monitor turn on.

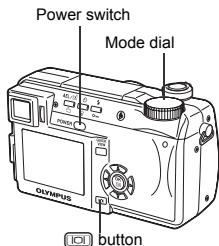

- 2 Press .**
 - The monitor turns off and the viewfinder turns on.

- 3 While looking through the viewfinder, slowly turn the diopter adjustment dial.**

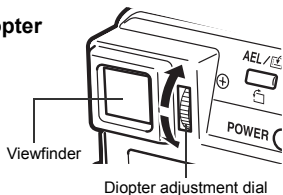

- 4 Turn the dial until the AF target mark can be seen clearly.**

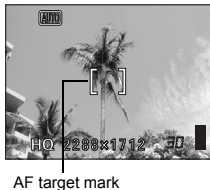

Holding the camera

Hold the camera firmly with both hands while keeping your elbows at your sides to prevent the camera from moving. When taking pictures in the vertical position, hold the camera so that the flash is higher than the lens. Keep your fingers and the strap away from the lens and flash.

Horizontal grip

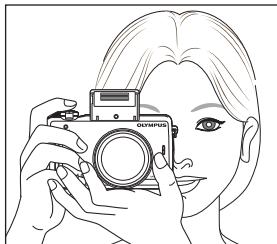

Vertical grip

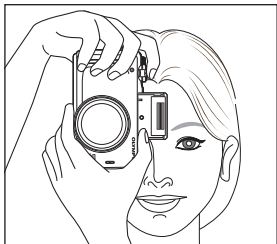

Top view

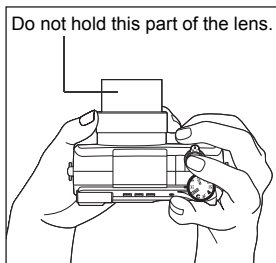

Note

- Clear pictures cannot be obtained if the camera moves as the shutter button is pressed. Hold the camera correctly, and press the shutter button gently.

1

Getting started

2 Using the menus

About the menus

When you turn on the camera and press , the top menu is displayed on the monitor. The functions of this camera are set from the menus. This chapter explains how the menus work, using the **P** mode screens.



The top menu is displayed.

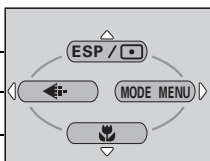

Press .

Top menu





Use the arrow pad to select a menu.

SHORTCUT MENU

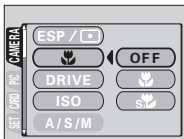
- Take you directly to the setting screens.
- Display operational buttons at the bottom of the screen.
- The functions registered in the shortcut menu can also be accessed from the MODE MENU.
- The shortcut menu can be replaced in modes other than **AUTO**  .  "Setting the shortcut menu" (P.141)



MODE MENU

- Lets you access the menu selections to set the ISO, sharpness, etc.
- Categorizes the settings into 4 tabs.
- Press   to select a tab and display the associated menu items.
- There is no mode menu in **AUTO** mode.

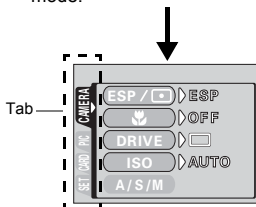

How to use the menus

1 Press to display the top menu. Press .

2 Press to select a tab, then press .

Top menu

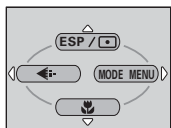

CAMERA tab

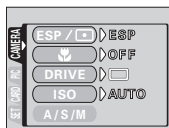

PICTURE tab

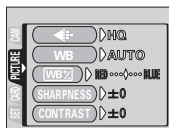

CARD tab

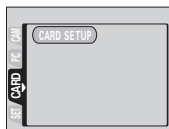

SETUP tab



Press to return to the tab selection screen.

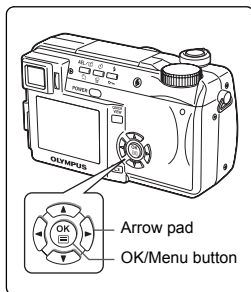

2

Using the menus

continued overleaf.

2

Using the menus

3 Press to select an item, then press .

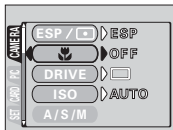
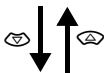
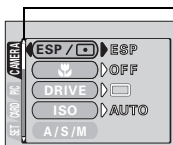

The green frame moves to the selected item.

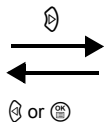

To return to select an item, press or .

4 Press to select a setting. Press to complete setting. Press again to exit the menu and return to shooting status.



Slider bar
This is also displayed on other pages with settings.

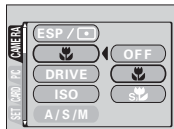
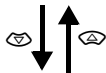
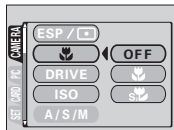

Note

- Not all items can be selected depending on the status of the camera and the settings performed.
- If you want to save the settings after the camera is turned off, set ALL RESET to OFF. "ALL RESET - Saving the camera's settings" (P.135)

Shortcut menu

● Shooting modes

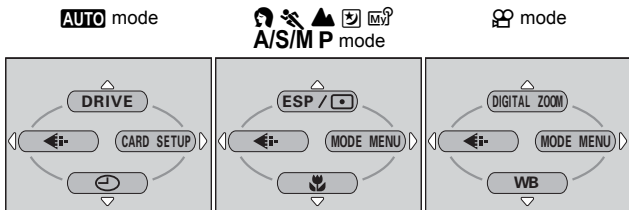

(Factory default setting)

DRIVE

Selects a shooting mode from (single-frame shooting), (sequential shooting), **HI** (high speed sequential shooting), **AF** (AF sequential shooting) and **BKT** (auto bracketing).

P.85

ESP/[]

Selects the metering method (ESP, or MULTI).

P.77

DIGITAL ZOOM

Extends the maximum optical zoom, making possible up to approx. 40× zoom.

P.56



Sets the image quality and resolution.
Still picture : TIFF*, SHQ, HQ, SQ1, SQ2
Movie : SHQ, HQ, SQ

P.96

*TIFF cannot be selected when the mode dial is set to **AUTO**.



Used to take pictures of a close subject. Selects OFF, or .

P.82

2

Using the menus

WB

Sets the appropriate white balance according to the light source.	P.103
---	-------



Sets the date and time.	P.28
-------------------------	------

CARD SETUP

Formats a card.	P.146
-----------------	-------

● Playback mode

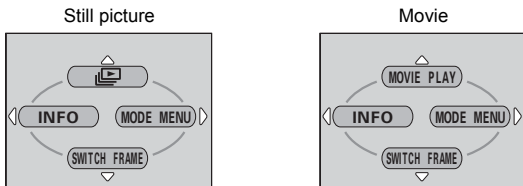

Runs through all saved pictures one after another.

P.118

MOVIE PLAY

MOVIE PLAYBACK	Plays back movies.	P.119
INDEX	Creates an index picture of a movie in 9 frames.	P.121
EDIT	Edits a movie.	P.123

INFO

Displays all the shooting information on the monitor.

P.148



SWITCH FRAME

Selects [ALL] to display all images or  to display only protected images.

P.132



TIPS

- The functions registered in the shortcut menu can also be accessed from the MODE MENU. The shortcut menu can be replaced in modes other than **AUTO**    "Setting the shortcut menu" (P.141)

Mode Menus

The MODE MENU has 4 tabs. Press to select a tab and display the associated menu items.



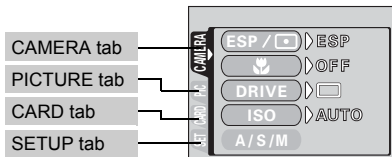

● Shooting modes





2

Using the menus

CAMERA tab		
ESP/	Selects the metering method (ESP, or MULTI).	P.77
	Used to take pictures of a close subject. Selects OFF, ,	P.82
DRIVE	Selects a shooting mode from (single-frame shooting), (sequential shooting), HI (high speed sequential shooting), AF (AF sequential shooting) and BKT (auto bracketing).	P.85
ISO	Selects the ISO sensitivity from AUTO, 64, 100, 200 and 400.	P.101
A/S/M	Selects the shooting mode from A (Aperture priority shooting), S (Shutter priority shooting) and M (Manual shooting).	P.65
1/2/3/4	Selects a mode to be activated when taking pictures in mode.	P.69
	Adjusts the amount of light emitted by the flash.	P.64
SLOW	Selects from SLOW1 (1st curtain), SLOW1 (1st curtain with red-eye reduction) and SLOW2 (2nd curtain) when the flash mode is set to SLOW (slow synchronization).	P.63
NOISE REDUCTION	Reduces the noise that affects pictures during long exposures.	P.110

DIGITAL ZOOM	Extends the maximum optical zoom up to approximately 40× magnification.	P.56
FULLTIME AF	Keeps the image in focus at all times without having to press the shutter button halfway.	P.71
AF MODE	Selects the auto focus method (iESP or SPOT).	P.70
	Enables you to take a picture of yourself while holding the camera.	P.88
PANORAMA	Allows panorama pictures to be taken with Olympus CAMEDIA-brand cards.	P.89
2 IN 1	Combines two still pictures taken in succession and stores them as a single picture.	P.91
FUNCTION	Adds special effects to pictures (BLACK & WHITE, SEPIA, WHITE BOARD, BLACK BOARD).	P.93
AF AREA	Changes the position of the AF target mark using the arrow pad.	P.72
INFO	Selects whether to display all the information such as shutter speed and white balance, or only the minimum information.	P.148
	Displays a histogram showing the luminance distribution of still pictures.	P.111
 (still pictures)	Sound can be recorded when taking still pictures.	P.94
 (movies)	Selects whether to record sound when shooting a movie.	P.95
SUPER ZOOM	Extends the optical zoom, making possible up to 14× zoom in 1600 × 1200 record mode.	P.55

PICTURE tab





	Sets the image quality and resolution. Still picture: TIFF, SHQ, HQ, SQ1, SQ2	P.96
WB	Sets the appropriate white balance according to the light source.	P.103
	Makes fine changes to the white balance.	P.106

SHARPNESS	Adjusts the sharpness of the image.	P.107
CONTRAST	Adjusts the contrast of the image.	P.108
SATURATION	Adjusts the level of color depth without changing the tint.	P.109

CARD tab



CARD SETUP	Formats a card.	P.146
------------	-----------------	-------

SETUP tab

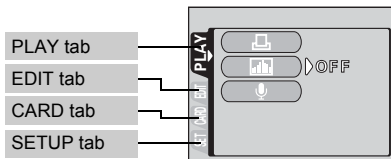

ALL RESET	Selects whether to keep the current camera settings when you turn off the power.	P.135
	Selects a language for on-screen display.	P.26
PW ON/OFF SETUP	Sets the picture that is displayed when the power is turned on and off.	P.152
REC VIEW	Selects whether to display pictures on the monitor while saving them to a card.	P.150
SLEEP	Sets the sleep timer.	P.151
MY MODE SETUP	Customizes settings which are activated in the  mode.	P.143
FILE NAME	Changes how file names are assigned.	P.154
PIXEL MAPPING	Checks the CCD and image processing functions for errors.	P.155
	Adjusts the brightness of the viewfinder or monitor.	P.149
	Sets the date and time.	P.28
m/ft	Sets the measurement unit (m/ft) used during manual focus.	P.156
VIDEO OUT	Selects NTSC or PAL according to your TV's video signal type. TV video signal types differ depending on the region.	P.157
SHORT CUT	Assigns frequently used functions as shortcut menus.	P.140
CUSTOM BUTTON	Assigns a frequently used function to the camera's custom button.	P.137
	Turns off the beep sound for button operations and warnings.	P.152

● Playback mode



PLAY tab ¹		
	Stores the necessary information on the card to allow you to print the pictures taken.	P.158
	Displays a histogram showing the luminance distribution.	P.111
	Adds sound to a still picture already taken.	P.127





¹ The PLAY tab is not displayed during movie playback.

EDIT tab ²		
	Makes the file size smaller and saves it as a new file.	P.128
	Crops part of a picture and saves it as a new file.	P.129

² The EDIT tab is not displayed during movie playback.

CARD tab		
CARD SETUP	Erases all image data stored on the card or format the card.	P.134, 146

SETUP tab		
ALL RESET	Selects whether to keep the current camera settings when you turn off the power.	P.135
	Selects a language for on-screen display.	P.26
PW ON/OFF SETUP	Sets the picture that is displayed when the power is turned on and off.	P.152

SCREEN SETUP	Registers a stored picture for use as the picture displayed when the power is turned on and off.	P.153
	Adjusts the brightness of the viewfinder or monitor.	P.149
	Sets the date and time.	P.28
VIDEO OUT	Selects NTSC or PAL according to your TV's video signal type. TV video signal types differ depending on the region.	P.157
	Selects the number of frames in the index display.	P.117
	Turns off the beep sound for button operations and warnings.	P.152

2

Using the menus

3 Shooting basics

Shooting modes

The shooting modes include modes where the optimal settings for the situation are automatically selected, and modes where you can select the settings best suited to the shooting conditions and the effect you wish to achieve.

You can change the shooting mode before and after turning the camera on.

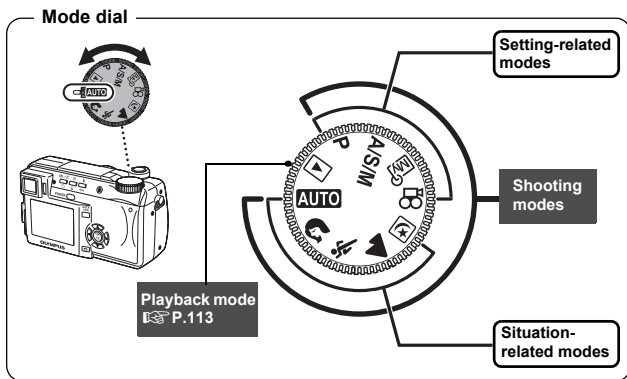

Situation-related modes

AUTO Full-auto shooting

Allows you to take still pictures using no special functions or manual adjustments. The camera sets the optimal focusing and exposure. This is the simplest of all shooting modes.

Portrait shooting

Suitable for taking a portrait-style shot of a person. This mode features an in-focus subject against a blurred background. The camera automatically sets the optimal shooting conditions.

Sports shooting

Suitable for capturing fast-moving action (such as sports) without blur. Even a fast-moving subject will be clear and sharp, as if it is not moving, enabling you to capture facial expressions and detailed activity. The camera automatically sets the optimal shooting conditions.

Landscape shooting

Suitable for taking pictures of landscapes and other outdoor scenes. Both the foreground and the background are in focus. Since blues and greens are vividly reproduced in this mode, it is excellent for shooting natural scenery. The camera automatically sets the optimal shooting conditions.

Night Scene shooting

Suitable for shooting pictures in the evening or at night. The camera sets a slower shutter speed than is used in normal shooting. For example, if you take a picture of a street at night in **AUTO** mode, the lack of brightness will result in a dark picture with the background underexposed and without details. In the Night Scene shooting mode, the true appearance of the street is captured. The camera automatically selects the optimal settings for this type of shooting condition. Since the shutter speed is slow, make sure you stabilize the camera by using a tripod.

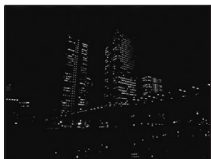

Setting-related modes

P Program shooting

Allows you to take still pictures. The camera sets the aperture and shutter speed. Other functions, such as flash modes and drive modes, can be adjusted manually.

A/S/M Aperture priority/Shutter priority/Manual shooting

When the mode dial is set to **A/S/M**, the following items can be set with the menus.  "A/S/M mode" (P.65).

A Aperture priority shooting

Allows you to set the aperture manually. The camera sets the shutter speed automatically. By decreasing the aperture value (F-number), the camera will focus within a smaller range, producing a picture with a blurred background. Increasing the value forces the camera to focus over a wider range in the forward and backward directions, resulting in increased "depth of field", in which both the subject and the background are in focus.

 "Aperture priority shooting" (P.66)



Aperture (F-number) is decreased.



Aperture (F-number) is increased.

S Shutter priority shooting

Allows you to set the shutter speed manually. The camera sets the aperture automatically. Set the shutter speed according to the subject and the type of effect you want.

 "Shutter priority shooting" (P.67)



Setting the shutter speed higher lets you capture fast-moving action without blur. The subject will be clear and sharp, as if it is not moving.



Setting the shutter speed lower blurs a moving subject, giving the impression of movement.

3

Shooting basics

M Manual shooting

Allows you to set the aperture and shutter speed manually. To check the exposure, refer to the exposure differential. This mode gives you more creative control, allowing you to make the settings you need to get the type of picture you want, regardless of optimum exposure.

"Manual shooting" (P.68)

My Mode

Allows you to save your favorite settings as your own personal mode and use these customized settings when taking pictures. Current settings can also be saved for retrieving by this mode. "MY MODE SETUP" (P.143)

"Using My Mode" (P.69)

Movie record

Allows you to record movies. The camera sets the aperture and shutter speed automatically. Even if the subject moves during recording or the distance to the subject changes, correct focusing and exposure are maintained continuously. If is set to ON, sound is recorded at the same time.

"Recording movies" (P.52)



Note

- The available settings vary depending on the mode. "Modes and Shooting Functions" (P.203)

Taking still pictures

You can take still pictures using either the monitor or the viewfinder.



- 1 Set the mode dial to **AUTO** **A/S/M P** and press the power switch.

"Power on/off" (P.24)

- The monitor turns on.

To shoot using the viewfinder, press to turn the viewfinder on.

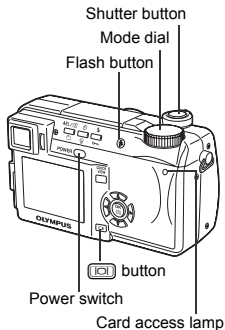

- 2 Decide the composition of the picture.





AF target mark

3

Shooting basics

3 Press the shutter button gently (halfway) to adjust the focus.

- When the focus and exposure are locked, the green lamp lights (focus lock).
- The AF target mark moves to the focused position.
- The shutter speed and aperture value automatically set by the camera are displayed (except in **M** mode).
-  blinks to warn of camera movement. Press the flash button to open the flash. (P.57)
- When  lights after the flash has popped up, the flash is ready to fire. The flash fires automatically when the shutter button is pressed all the way.

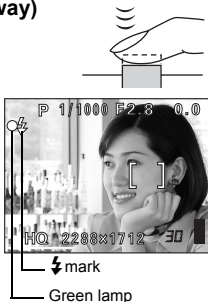

4 Press the shutter button all the way (fully).

- The camera takes the picture.
- The card access lamp blinks while the picture is stored on the card.



TIPS

The subject cannot be focused on.

 "If correct focus cannot be obtained" (P.50)

The green lamp blinks.

→ You are too close to the subject. Take the picture at least 7 cm/2.8" (wide-angle) (1.2 m/3.9 ft. (telephoto)) away from the subject. If you use the super macro mode, you can take pictures as close as 3 cm/1.2" from the subject. (P.83)

→ Depending on the subject, the focus and exposure may not be locked.  "Subjects that are difficult to focus on" (P.51)



 blinks when the shutter button is pressed halfway.

→ The flash is charging. Wait until the lamp goes off.

To check the picture you have just taken immediately

→ Set Rec View to ON.  "REC VIEW" (P.150)

To record sound with the picture

- You can record sound when taking still pictures. Set  to ON.
 “Recording sound with still pictures” (P.94) You can also add sound to a picture that has already been taken.  “Recording sound” (P.127)

The monitor or viewfinder turns off automatically

- If the camera is not used for over 3 minutes, the monitor and viewfinder turn off automatically. Operate the shutter button or zoom lever to turn the viewfinder or monitor on.  “SLEEP - Sleep Timer” (P.151)



To adjust the brightness of the monitor or viewfinder

- Go to “Monitor brightness Adjustment” and adjust the brightness.
 “Monitor/viewfinder brightness adjustment” (P.149)

The monitor or viewfinder is hard to see

- Bright light, such as direct sunlight, may cause vertical lines (smears) to appear on the image in the monitor or viewfinder. This does not affect recorded pictures.

To check the area the camera is focusing on

- If you press  while pressing the shutter button halfway, the area you are focusing on is enlarged. Pressing  once more returns the size to normal. This function is not available in the digital zoom range.
 “DIGITAL ZOOM - Using the digital zoom” (P.56)



Note

- Press the shutter button gently using the ball of your finger. If it is pressed hard, the camera may move and pictures may come out blurred.
- Recorded pictures will be saved on the card regardless of whether the camera is turned off or the batteries are replaced or removed.
- Never open the battery compartment/card cover, remove the battery or disconnect the AC adapter while the card access lamp is blinking. Doing so could destroy stored pictures and prevent storage of pictures you have just taken.
- When taking pictures against strong backlight, the area of the picture in shadow may appear colored.

If correct focus cannot be obtained

When the subject cannot be focused on, you can focus the camera on another point at roughly the same distance (focus lock) and take the picture as explained below.

Using the Focus Lock function

Mode dial

AUTO



A/S/M

P

- 1 Position the AF target mark on the subject you want to focus on.**

- When shooting a hard-to-focus subject or a fast-moving subject, point the camera at an object about the same distance away as the subject.



AF target mark

- 2 Press the shutter button halfway until the green lamp lights.**

- When the focus and exposure are locked, the green lamp lights.
- The AF target mark moves to the focused position.
- When the green lamp blinks, the focus and exposure are not locked. Release your finger from the shutter button, re-position your subject and press the shutter button halfway again.

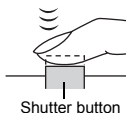

Shutter button

- 3 Keeping the shutter button pressed halfway, recompose your shot.**



4 Press the shutter button fully.

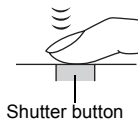

TIPS
The frame in which you focus on a subject is different from the frame in which you lock the exposure.

☞ “AE LOCK – Locking the exposure” (P.80)

Fix the focus position.

☞ “AF LOCK – Locking the focus” (P.73)

Focus on the subject in the center of the frame.

☞ “AF MODE – Changing the focus range” (P.70)

Subjects that are difficult to focus on

Under certain types of conditions, the auto focus may not work properly. If this happens, focus on an object with high contrast at the same distance as the intended subject (focus lock), recompose your shot and then take the picture. If the subject has no vertical lines, hold the camera vertically and focus the camera using the focus lock function by pressing the shutter button halfway, then return the camera to the horizontal position while keeping the button pressed halfway and take the picture.

If the subject still cannot be focused on, use the manual focus. ☞ “Manual focus” (P.75)

The green lamp blinks.
 The subject cannot be brought into focus.



Subject with low contrast



Subject with an extremely bright area in the center of the frame

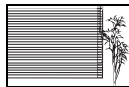

Subject without vertical lines

The green lamp lights, but the subject cannot be brought into focus.



Subjects at different distances



Fast-moving subject



The subject to be focused on is not in the center of the frame.

Recording movies



This function allows you to record movies. If  is set to ON, sound is recorded at the same time.

Mode dial



1 Set the mode dial to and press the power switch.

 "Power on/off" (P.24)

- The monitor turns on.
- The available recording time on the card that you are using is displayed.

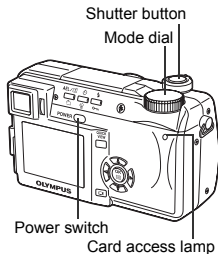

2 Decide the composition of the picture.

- You can use the zoom lever to enlarge your subject.



3 Press the shutter button fully to start recording.

- You can adjust the zoom during movie recording.
- The card access lamp blinks while the movie is stored on the card.
- During movie recording,  lights red.







Time remaining

4 Press the shutter button again to stop recording.

- When the remaining recording time has been used up, recording stops automatically.
- When there is space in the card memory, the remaining recording time ( P.99) is displayed, and the camera is ready to shoot.



Note

- Depending on the card, the remaining recording time may drop rapidly during recording. Try using the card again after formatting it with your camera.  "CARD SETUP – Formatting cards" (P.146)
- When  is set to ON, the position of the optical zoom cannot be changed during movie recording. To use the zoom during recording, set DIGITAL ZOOM to ON.  "DIGITAL ZOOM - Using the digital zoom" (P.56)
- In  mode, the flash and manual focus (MF) cannot be used.
- This camera cannot play back sound.

Notes for recording movies over a long time

- Recording will continue until the card is full unless stopped by pressing the shutter button.
- A long recorded movie cannot be edited. (P.121)
- If a single movie recording uses up all of the card's memory, create space on the card by deleting the movie or downloading it to a PC.

Zoom

In addition to the optical zoom, this camera is equipped with a super zoom and digital zoom for taking telephoto and wide-angle shots. You can increase the zoom magnification by combining the super zoom or digital zoom with the optical zoom. The super zoom and digital zoom cannot be used at the same time. Camera movement is likely to occur at higher magnifications. Stabilize the camera with a tripod, etc. to avoid camera movement.

The characteristics and maximum magnification of each zoom are shown below.

- Optical zoom** Use for normal zoom shooting.
Max. magnification: 10× (equivalent to 38 mm to 380 mm on a 35 mm camera)
- Super zoom** Use to extend the optical zoom up to 14× magnification. However, the resolution is automatically fixed at 1600 × 1200.
Max. magnification: 14×
- Digital zoom** Use to extend the maximum optical zoom. However, pictures taken with the digital zoom may appear grainy.
Max. magnification: Approx. 40×
(Digital zoom magnification during movie recording is 2.5×)

Using the optical zoom

Mode dial



1 Push or pull the zoom lever.

Zoom lever



Wide-angle: Push the zoom lever toward W to zoom out.





Telephoto: Pull the zoom lever toward T to zoom in.

SUPER ZOOM – Using the super zoom

Mode dial



- 1** In the top menu, select **MODE MENU** → **CAMERA** → **SUPER ZOOM** → **ON**, and press .

 “How to use the menus” (P.33)

- When ON is selected, the record mode is automatically set to 1600 × 1200.
- Press  again to exit the menu.

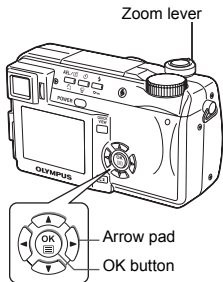

- 2** Pull the zoom lever toward **T** until the optical zoom reaches its limit.

- When 10× magnification is reached, zoom adjustment stops. To zoom in further, keep pulling the zoom lever toward T.

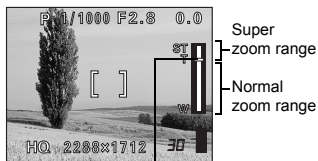

The cursor turns orange when inside the super zoom field.

- 3** Push the zoom lever toward **W** to zoom out.

- When the zoom reaches 10× magnification, zoom adjustment stops. To zoom out further, keep pushing the zoom lever toward W.





- Setting DIGITAL ZOOM to ON or changing the record mode setting automatically disables the super zoom.

DIGITAL ZOOM - Using the digital zoom

Mode dial



- In the top menu, select **MODE MENU** → **CAMERA** → **DIGITAL ZOOM** → **ON**, and press .

 “How to use the menus” (P.33)

- Press  again to exit the menu.

Zoom lever

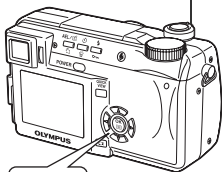

Mode dial



- In the top menu, select **DIGITAL ZOOM** → **ON**, and press .

- Pull the zoom lever toward **T**.

- The white area of the zoom indicator indicates the optical zoom. If the digital zoom is set to ON, a red area appears on the zoom indicator. When you reach the limit of the optical zoom, the digital zoom is enabled.



The cursor moves up and down on the zoom indicator according to the zoom magnification.

The cursor turns orange when inside the digital zoom field.



Note

- Pictures taken with the digital zoom may appear grainy.

4 Flash

Flash shooting



Select the flash mode best suited to the light conditions and the effect you want to achieve. You can also adjust the amount of light emitted using the flash intensity control.

Mode dial

AUTO



A/S/M

P

1 Press the flash button. (①)

- The flash pops up. (②)

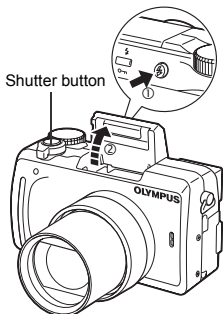

2 Set the flash mode by repeatedly pressing

- The flash mode changes in the sequence shown below (when all modes are available).

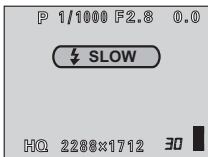
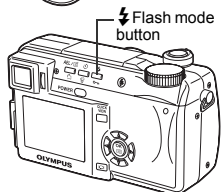
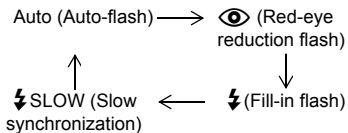

- If no operation is performed for about 3 seconds, the flash mode is set and the mode selector screen is automatically exited.
- To prevent the flash from firing, press down on the top of the flash to retract it.

4

Flash

3 Press the shutter button halfway.

- In conditions where the flash will fire,  lights.

4 Press the shutter button fully to take the picture.

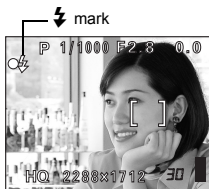









Flash working range

W (max.) : Approx. 0.3 m to 4.5 m (1.0 ft. to 14.8 ft.)

T (max.) : Approx. 1.2 m to 3.5 m (3.9 ft. to 11.5 ft.)

Function restrictions according to mode

Flash mode	Mode			Mv+	A/S/M			P
	AUTO				A	S	M	
Auto	✓	✓	✓	✓	✓	–	✓	
	✓	✓	✓	✓	✓	–	✓	
	–	✓	✓	✓	✓	–	✓	
 SLOW1	–	✓	✓	✓	✓	✓	✓	
 SLOW2	–	✓	✓	✓	✓	✓	✓	
  SLOW1	–	✓	✓	✓	✓	–	✓	
	✓	✓	✓	✓	✓	✓	✓	

✓: Available, –: Not available, : Factory default setting

* The factory default settings and available modes vary depending on the selected mode.

**TIPS** - - - - -

The ⚡ (flash charge) indication blinks.

→ The flash is charging. Wait until ⚡ goes off.

Camera movement warning (Auto-flash, red-eye reduction flash, fill-in flash)

→ When ⚡ (camera movement warning) lights, the shutter speed locks at its current level. This helps prevent camera shake problems (shutter speeds that are too slow can cause blur). However, if the zoom magnification is increased, the camera will increase the locked shutter speed accordingly.

Zoom position	Shutter speed
W (max.)	1/30 sec.
T (max.)	1/320 sec.



Note

- The flash does not fire in the following situations:
In the movie record mode, during auto bracketing, during super-macro shooting, when FUNCTION is set to WHITE BOARD/BLACK BOARD, and during Panorama shooting
- The flash may not give you the optimum result in macro mode, especially with wide-angle shooting. Check the resulting picture on the monitor.
- If a conversion lens is attached to the camera, do not use the flash.

●Auto-flash (No indication)

The flash fires automatically in low light or backlight conditions.

To shoot a subject with backlight, position the AF target mark over the subject.

●Red-eye reduction flash (👁)

The light from the flash may make the subject's eyes appear red in the picture. The red-eye reduction flash mode significantly reduces this phenomenon by emitting pre-flashes before firing the regular flash. This helps accustom the subject's eyes to the bright light and minimizes the red-eye phenomenon.



The subject's eyes appear red.

4

Flash



Note

- After the pre-flashes, it takes about 1 second before the shutter is released. Hold the camera firmly to avoid camera movement.
- Effectiveness may be limited if the subject is not looking directly at the pre-flashes, or if the shooting range is too far. Individual physical characteristics may also limit effectiveness.

●Fill-in flash (⚡)

The flash fires regardless of the available light. This mode is useful for eliminating shadows on the subject's face (such as shadows from tree leaves), in a backlight situation, or for correcting the color shift produced by artificial lighting (especially fluorescent light).



Note

- The fill-in flash may not have the desired effect under excessively bright light.

● Flash off (🚫)

The flash does not fire even in low light conditions. Use this mode in situations where flash photography is not desired or is prohibited. You can also use this mode when you want to shoot a natural-looking twilight or night scene.



Note

- Since a slow shutter speed is automatically selected in low light situations when in the flash off mode, the use of a tripod is recommended to prevent your pictures from being blurred by camera movement.

● Slow Synchronization (⚡ SLOW1 ⚡ SLOW2 📷 ⚡ SLOW1)

The slow synchronization flash is designed for slow shutter speeds. Normally, when shooting with a flash, shutter speeds cannot go below a certain level to prevent camera movement. But when shooting a night scene background, fast shutter speeds can make the background too dark. Slow synchronization flash allows both a slow shutter speed for the background and a flash for the subject. Since the shutter speed is slow, make sure you stabilize the camera by using a tripod. Otherwise, camera movement may cause the picture to be blurred.

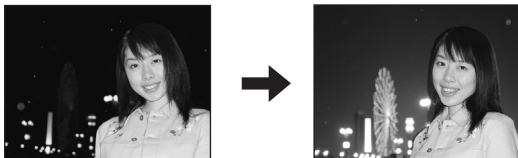

1st curtain (front curtain) ⚡ SLOW1

Usually, regardless of the shutter speed, the flash fires right after the shutter fully opens. This is called 1st curtain. Unless you change it, this is how the flash always fires. The slow synchronization factory default setting is ⚡ SLOW1.

2nd curtain (rear curtain) ⚡ SLOW2

With 2nd curtain, the flash fires just before the shutter closes. Changing the flash timing can create interesting effects in your picture, such as expressing the movement of a car by showing the tail-lights streaming backwards. The slower the shutter speed, the better the effects turn out.

The slowest possible shutter speed depends on the shooting mode:

M mode : 15 sec.

P, A, S, [] mode : 4 sec.

When the shutter speed is set to 4 sec.

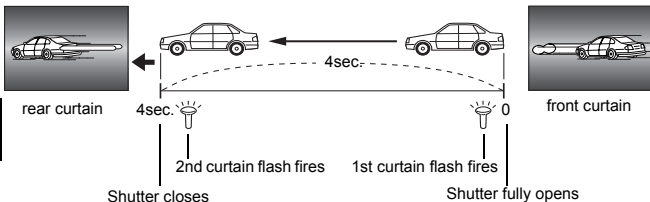

4

Flash







1st curtain with red-eye reduction 👁 ⚡ SLOW1

This mode is for when you want to use slow synchronization, yet also reduce the red-eye phenomenon. For instance, when shooting a person against a brightly lit night background. A normal flash might make the person's eyes red, but 1st curtain with red-eye reduction lets you capture the background correctly and reduce the red-eye phenomenon at the same time. 2nd curtain with red-eye reduction is not available.

Using the slow synchronization flash SLOW

Mode dial



- 1 In the top menu, select **MODE MENU** → **CAMERA** →  **SLOW** →  **SLOW1**,   **SLOW**,  **SLOW2**, and press .

 “How to use the menus” (P.33)

- Press  again to exit the menu.

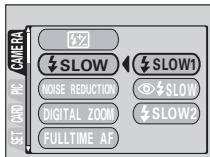

4

Flash

Flash intensity control



You can adjust the amount of light emitted by the flash.

In some situations, you may get better results by adjusting the light emission. Examples include small subjects, distant backgrounds, or situations when increased contrast is desired. You can adjust the exposure in the range of ± 2.0 in $1/3$ EV steps.

Mode dial



- 1 In the top menu, select **MODE MENU** → **CAMERA** → , and press .

"How to use the menus" (P.33)

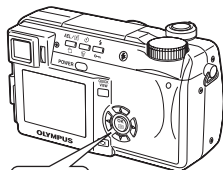

Arrow pad
OK button

- 2 Press to adjust the exposure, then press .

: Light emission is increased by $1/3$ EV each time you press the button.

(EV : Exposure Value)

: Light emission is decreased by $1/3$ EV each time you press the button.

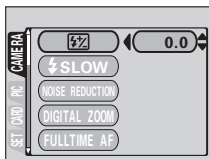

- Press again to exit the menu.



Note

- The flash adjustment effect may not be sufficient if the shutter speed is too fast.

5 Advanced shooting

A/S/M mode

A/S/M

Select the shooting mode to be used when the mode dial is set to **A/S/M**.

Mode dial

A/S/M

- 1 In the top menu, select **MODE MENU** → **CAMERA** → **A/S/M** → **A**, **S** or **M**, and press .

 “How to use the menus” (P.33)

- Press  again to exit the menu.

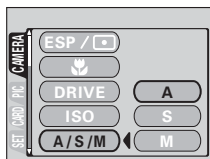
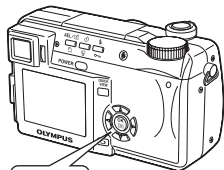

5

Advanced shooting

Mode dial

A/S/M

1 Select A mode.

Press the "A/S/M mode" (P.65)

2 Press to set the aperture value.

 : The aperture value increases.

 : The aperture value decreases.

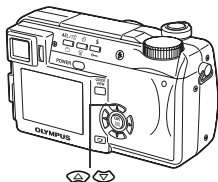

If the aperture value is displayed in red, the aperture setting is unsuitable for the conditions. Take the following steps. (When the aperture value is displayed in green, the setting will provide optimum exposure.)

5

Advanced shooting

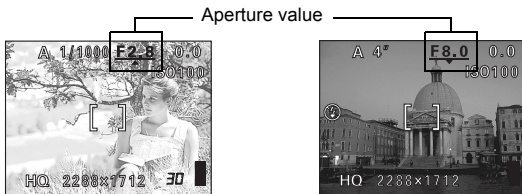

▲ appears : The image is overexposed.

Press  to increase the aperture value.

Aperture range : Toward W : f2.8 to f8.0

Toward T : f3.7 to f8.0

▼ appears : The image is underexposed.

Press  to decrease the aperture value.



Note

- When the flash is set to the auto-flash mode, the shutter speed is fixed at 1/30 sec. in the maximum wide angle, or 1/320 sec. in the maximum telephoto, and will not go slower.

Mode dial

A/S/M

1 Select S mode.

Press "A/S/M mode" (P.65)

2 Press to set the shutter speed.

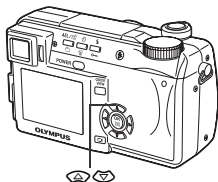

 : Sets a faster shutter speed.

 : Sets a slower shutter speed.





If the shutter speed is displayed in red, the setting is unsuitable for the conditions. Take the following steps. (When the shutter speed is displayed in green, the setting will provide optimum exposure.)



 appears : The image is overexposed.
Press  to set a faster shutter speed.



 appears : The image is underexposed.
Press  to set a slower shutter speed.

Shutter speed range: 1" to 1/1000



Note

- Shutter speeds that can be set differ according to the flash setting.

Mode dial

A/S/M

1 Select M mode.

"A/S/M mode" (P.65)

2 Use the arrow pad to set the aperture value and shutter speed.

- : The aperture value increases.
- : The aperture value decreases.
- : Sets a faster shutter speed.
- : Sets a slower shutter speed.

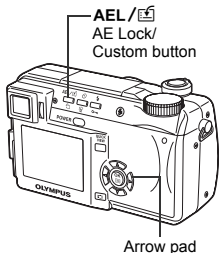

- When the shutter button is halfway pressed, the difference (ranging from -3.0 to +3.0 EV) between the exposure determined by the currently selected aperture and shutter speed compared to the exposure level considered optimal by the camera is displayed.
- If the exposure differential appears in red, it indicates that the exposure differential is less than -3.0 EV or more than +3.0 EV.
- When you press **AEL** / , the screen on the right appears with the bar indicating current exposure settings.

Exposure differential



Aperture value : f2.8 to f8.0 (W)

f3.7 to f8.0 (T)

Shutter speed : 15" to 1/1000



Note

- To avoid camera movement, you are recommended to use a tripod when taking pictures requiring a slow shutter speed.

When you use mode, the settings you selected with the menus in My Mode are activated.

Saving the shooting mode or function settings you want to use in advance lets you shoot with your favorite settings straightaway. You can also save the settings you are currently using. You can create and save up to 4 different patterns. “MY MODE SETUP” (P.143)

Mode dial



- 1 In the top menu, select **MODE MENU** → **CAMERA** → 1/2/3/4 → **MY MODE 1 to MY MODE4**, and press .

“How to use the menus” (P.33)

- Press again to exit the menu.
- Only the settings in MY MODE 1 have already been saved. You cannot select MY MODE 2 to MY MODE 4 if no settings have been saved in them.

“MY MODE SETUP” (P.143)



Arrow pad
OK button



Note

- Although the settings you are using can be saved, the zoom saved may not be the same as the one being used.

Focusing applications

AF MODE – Changing the focus range

This function allows you to select the focus range of your subject.

- iESP** Focus selection is based on the entire picture on the screen. Even when the subject is not in the center of the screen, focusing is possible.
- SPOT** Focus selection is based on the subject within the AF target mark.

Mode dial



- 1** In the top menu, select **MODE MENU** → **CAMERA** → **AF MODE** → **iESP** or **SPOT**, and press .
☞ “How to use the menu” (P.33)

- Press again to exit the menu.

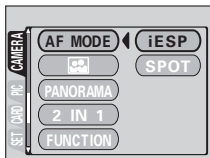
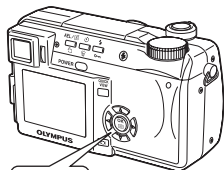

Note

- In **AUTO** and mode, the AF MODE is fixed at iESP and cannot be changed.

FULLTIME AF – A reliable time-saving way to focus

FULLTIME AF keeps the subject in front of the lens in focus at all times, without having to press the shutter button halfway. When ON is selected, the focusing time is reduced, letting you take successive snapshots.



- In the top menu, select **MODE MENU** → **CAMERA** → **FULLTIME AF** → **ON**, and press .

“How to use the menus” (P.33)

- Press again to exit the menu.

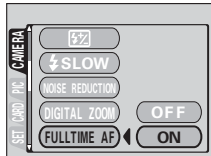
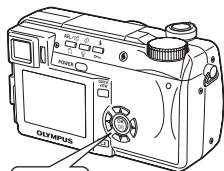

5

Advanced shooting



Note

- Battery consumption increases when FULLTIME AF is used.

AF AREA – Changing the position of the AF target mark

You can select the area you want to focus on by changing the position of the AF target mark.

Mode dial



1 Set the AF MODE to SPOT.

☞ “AF MODE – Changing the focus range” (P.70)

2 In the top menu, select MODE MENU → CAMERA → AF AREA, and press .

☞ “How to use the menus” (P.33)

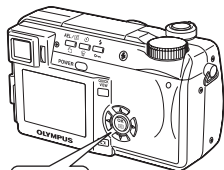

Arrow pad

OK button

3 Use the arrow pad to move the AF target mark to the area you want to focus on.

- The AF target mark at the center of the screen can be moved vertically or horizontally.

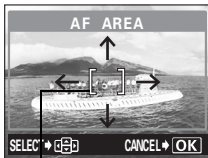

AF target mark

4 Take the picture.

- To restore the AF target mark to its original position (at the center), press .
- Press again to exit AF target mark selection mode.



Note

- AF AREA is not available when the digital zoom is set to ON.
- The location of the AF target mark cannot be saved.

AF LOCK – Locking the focus

Registering the AF lock function on the **AEL** /  in advance enables easy locking of the focus.



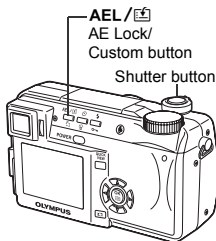

1 Register the AF lock function on **AEL** / .

 “Setting the custom button” (P.138)



2 Position the AF target mark on the subject you want to focus on and press **AEL** / .

- The focus is locked and the AF LOCK mark is displayed.
- To reset the AF LOCK, press **AEL** /  again to cancel the AF LOCK. Each time you press **AEL** / , AF lock is alternately engaged and canceled.

When **AEL** /  is pressed



When focus is locked



AF LOCK mark

3 Press the shutter button fully.

**TIPS****How to save the locked focus after shooting (AF MEMORY)**

- Hold down **AEL** / for more than 1 second. The AF MEMORY mark appears. When the mark appears, the locked focus is memorized. To cancel AF MEMORY, press **AEL** / again.

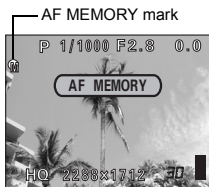
**AF LOCK was canceled.**

- Do not operate any of the buttons or the mode dial after performing AF LOCK. AF LOCK will be canceled.
- The camera had emerged from sleep mode or the power was turned off.



Note

- The focus may be compromised by operating the zoom after setting the AF LOCK. Complete zoom operations before setting the AF LOCK.
- AF LOCK is not available when a menu is displayed on the screen. Exit the menu. "How to use the menus" (P.33)

Manual focus

If auto focus is unable to focus on a subject, use manual focus.



- 1** Hold down  for more than 1 second.



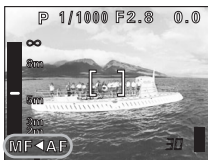

- 2** When the focus distance selection screen appears on the monitor, press  to select MF.

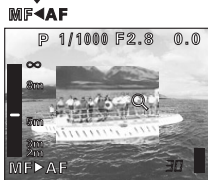

- 3** Press   to set the focus position.

- During operation, the area you are focusing on is enlarged. This lets you check whether the focus is in the right position.
- The distance indicator on the left of the monitor is for reference only.
- When the indicator is moved to less than 2 m (6.6 ft.), the display automatically switches to the 7 cm (2.8") to 2 m (6.6 ft.) display.





- 4** Hold down  for more than 1 second to save the setting.
- MF is displayed in red on the monitor.

5 Take the picture.

- The focus is locked at the distance you have set.

● To cancel manual focus

- 1 Hold down  for more than 1 second to display the focus distance selection screen.
- 2 Press  to select AF, then press .
 - Manual focus is canceled.



5





TIPS - - - - -

How to shoot while keeping the same focus distance at all times

→ The focus can be fixed at the same distance as when you perform focus lock.

- 1 Position the AF target mark on a subject at the desired distance and press the shutter button halfway.
- 2 Keeping the shutter button half-pressed, press .
 - The distance indicator is displayed.
 - MF is selected and the focus is locked at the same distance as when you performed focus lock.

Even if you move the cursor to the top of the distance indicator, focusing is not possible at ∞.

→ Adjust the cursor position by pressing   while watching the monitor.



Note

- If the zoom lever is pressed after performing manual focus, the saved focus distance may be changed. Perform setting again.



There are three ways of measuring the brightness of a subject.

- ESP metering** Meters the center of the subject and the surrounding area separately.
- Spot metering** Exposure is determined by metering within the AF target area. In this mode, a subject can be shot with optimal exposure regardless of the background light. P.77
- Multi-metering** Meters the brightness of the subject at up to 8 different points to set the optimal exposure based on the average brightness. This method is useful with a high contrast subject. P.78

Spot metering

Mode dial



1 In the top menu, select ESP/ →

and press .

- In the top menu, the setting can be made in the same way as selecting MODE MENU → CAMERA → ESP/ → .

"How to use the menus" (P.33)

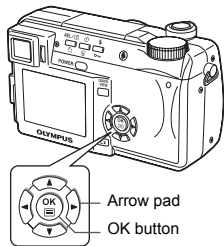

MULTI METERING

Mode dial





- 1** When using the camera in the **A/S/M** mode, multi-metering is not available in the **M** mode. Set to any mode except **M**.

☞ "A/S/M mode" (P.65)

- If a function other than AE lock is registered on **AEL** / , set AE lock to the button.

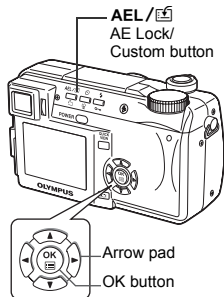
☞ "Setting the custom button" (P.138)



- 2** In the top menu, select **ESP** /  → **MULTI**, and press .

- In the top menu, the setting can be made in the same way as selecting **MODE MENU** → **CAMERA** → **ESP** /  → **MULTI**.



☞ "How to use the menus" (P.33)

- Press  again to exit the menu.

- 3** Position the **AF** target mark on the area you want to meter and press **AEL** / . The brightness is metered at up to 8 different points.

- Multi-metering bar appears.
- Brightness meter readings are ignored after the 9th reading.

- To perform metering again, press

AEL /  for more than 1 second to display . Press **AEL** /  again to cancel the metering values.







Ex: When metering 2 points (pressing **AEL**/ twice)

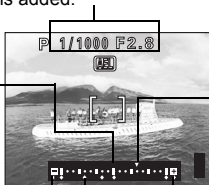

The aperture and shutter speed as calculated from the average values obtained by metering at 2 points. These values are recalculated every time another metering point is added.

The average for the 2 metering points. The average is always shown at the center of the bar.



Indicates how much the present exposure you are metering differs from the average exposure value. The present exposure can be fixed by pressing the shutter button halfway. (The present exposure is not added to the average value unless you press **AEL**/.)



The reading when **AEL**/ was pressed. The number of  indicates the number of times you have pressed the button. The distance  is from the center of the bar indicates the difference between the metered and average readings.

When  moves more than ± 3 from the center of the bar (the average reading), red  appear.



TIPS - - - - -

To save the locked multi-metering exposure after shooting (AE memory)

→ After metering in step 3, hold down **AEL**/ for more than 1 second. **MEMO** appears. While **MEMO** is displayed, the exposure is saved. Press **AEL**/ again to cancel the AE memory.

The multi-metering exposure is canceled.

→ If you operate any of the buttons or the mode dial after metering in step 4, the multi-metering exposure is canceled.

This function is suitable for situations when optimal exposure is difficult to achieve, such as when there is excessive contrast between the subject and the surroundings.

For example, when the sky takes up much of the frame, shooting with automatic exposure sometimes results in a dark subject. Then press **AEL** /  to lock the metered value (exposure) temporarily. Next, compose your shot again with the sky in the frame and take the picture.



5

Advanced shooting

Mode dial



- 1** When using the camera in the **A/S/M** mode, **AE lock is not available in the M mode. Set to any mode except M.**

 “A/S/M mode” (P.65)

- If a function other than AE lock is registered on **AEL** / , set AE lock to the button.

 “Setting the custom button” (P.138)

- 2** Compose the picture where you want to lock the metered value (exposure), then press **AEL** / .

- The exposure is memorized.
- If you want to lock a different exposure, press **AEL** /  again to cancel AE lock. Each time you press **AEL** / , AE lock is alternately engaged and canceled.

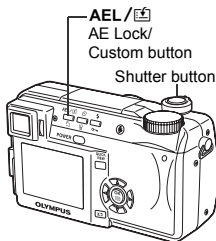

During AE lock, **AEL** is displayed.

3 Position the AF target mark on the subject you want to focus on and press the shutter button halfway.

- The green lamp lights.
- AE lock cannot be canceled while the shutter button is pressed halfway.

During AE lock, AEL is displayed.





4 Press the shutter button fully.

- AE lock is automatically canceled after one shot.



TIPS

To save the locked metered value (exposure) after shooting (AE memory)



→ After step 2 or 3, hold down **AEL**/ for more than 1 second. **MEMO** appears. While **MEMO** is displayed, the exposure is saved. Press **AEL**/ again to cancel the AE memory.

AE lock was canceled.

- Do not operate any of the buttons or the mode dial after performing AE lock. Doing so will cancel AE lock.
- The camera had emerged from sleep mode or the power was turned off.





Note

- AE lock is not available when multi-metering is enabled. Turn multi-metering off.  “MULTI METERING” (P.78)
- AE lock is not available when a menu is displayed on the screen. Exit the menu.  “How to use the menus” (P.33)

Macro mode shooting



Focusing is usually slow when you get close to a subject (W: 7 cm/2.8" to 60 cm/2.0 ft., T: 1.2 m/3.9 ft. to 2 m/6.6 ft.). However, in the  mode focusing is performed quickly. When the optical zoom lever is at the maximum wide position and you are as close as 7 cm/2.8" to your subject, you can fill the entire frame with your subject.

If the center of the frame (within the AF target mark) is metered when you are close to the subject and you shoot with the optimal exposure, the picture will turn out well.  "Spot metering" (P.77)



Normal shooting



With the macro mode



5

Mode dial



Advanced shooting

- 1 In the top menu, select  → , and press .

- In the top menu, the setting can be made in the same way as selecting MODE MENU → CAMERA →  → .

 "How to use the menu" (P.33)

- You cannot select  in manual focus mode. Set to AF.

 "Manual focus" (P.75)

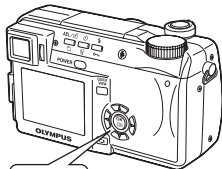

Super macro mode shooting



This mode lets you shoot from as close as 3 cm/1.2" to your subject. Subjects measuring up to approximately 4 × 3 cm (1.6" × 1.2") can be captured on the monitor.

In the **sM** mode, normal shooting is also possible, but the position of the zoom is fixed automatically and cannot be changed.

Mode dial



1 In the top menu, select → **sM**, and press .

- In the top menu, the setting can be made in the same way as selecting MODE MENU → CAMERA → → **sM**.
- "How to use the menu" (P.33)
- Press again to exit the menu.



TIPS

The subject is in shadow

→ When taking pictures close to the subject, shadows may become conspicuous, and the auto focus may not be able to maintain correct focus. If this happens, use the manual focus. ➤ "Manual focus" (P.75)



Note

- During super macro shooting, the flash is not available.

Self-timer shooting



This function lets you take pictures using the self-timer. Fix the camera securely on a tripod for self-timer shooting. This function is useful for taking pictures where you want to be included in the photograph.

Mode dial

AUTO



A/S/M

P

1 Select by repeatedly pressing .

- If no operation is performed for about 3 seconds, the selected mode is set and the mode selector screen is automatically exited.

Self-timer button

Shutter button

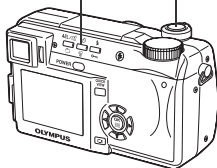

P 1/1000 F2.8 0.0



HQ 2288x1712 30

2 Press the shutter button fully to take the picture.

- Pressing the shutter button halfway locks the focus and exposure.
- The self-timer lamp lights for approximately 10 seconds, then starts blinking. After blinking for approximately 2 seconds, the picture is taken.
- To stop shooting while in mode, press the shutter button fully again.
- To cancel the self-timer, press .
- The self-timer mode is automatically canceled after one shot.

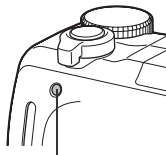

Self-timer lamp



Note

- If sequential shooting is attempted in self-timer mode, the camera shoots max. 5 frames regardless of the setting.



There are 4 sequential shooting modes: sequential shooting, high speed sequential shooting, AF sequential shooting and auto bracketing. Sequential shooting modes can be selected from the DRIVE mode menu. Sequential shooting cannot be performed when the record mode is set to TIFF.

Drive mode

Shoots 1 frame at a time when the shutter button is pressed. (Normal shooting mode, single-frame shooting)



Focus, exposure and white balance are locked at the first frame. Approx. 7 frames at approx. 1.6 frames/sec. (in HQ mode)



Pictures can be taken at a faster speed than normal sequential shooting. The sequential shooting speed varies depending on the record mode setting. Approx. 2 frames at approx. 2.1 frames/sec.



Focus is individually locked for each frame. The AF sequential shooting speed is slower than for normal sequential shooting.



"Auto bracketing" (P.86)

Sequential shooting, high speed sequential shooting and AF sequential shooting



Mode dial



- 1 In the top menu, select **MODE MENU** → **CAMERA** → **DRIVE** → , or , and press .
 "How to use the menus" (P.33)

Mode dial



- In the top menu, select **DRIVE** → , or , and press .
- Press again to exit the menu.

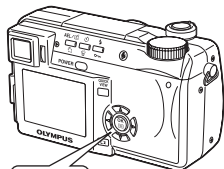

Arrow pad

OK button

2 Take the picture.

- Press the shutter button fully and keep it pressed. The camera will take pictures in sequence until you release the button.

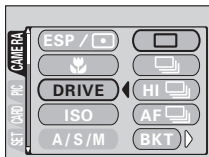

Auto bracketing

BKT

Under some conditions, you may obtain better results shooting with exposure compensation than by using the exposure setting considered optimal by the camera.

When auto bracketing is set, the exposure is changed automatically for each frame when you start shooting. The exposure differential and number of frames can be selected in the menus. The focus and white balance are locked at the first frame.

Ex: When **BKT** is set to $\pm 1.0 \times 3$

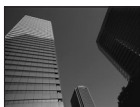

-1.0



0.0



+1.0

Mode dial



A/S/M

P

- 1 In the top menu, select **MODE MENU** → **CAMERA** → **DRIVE** → **BKT**, and press

"How to use the menus" (P.33)

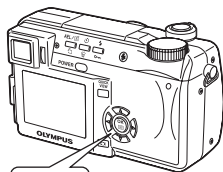

Arrow pad

OK button

- 2 Select the exposure differential.**
Press to select ± 0.3 , ± 0.7 or ± 1.0 , then press .

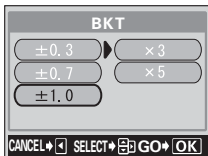

- 3 Select the number of shots.** Press to select $\times 3$ or $\times 5$, then press .
- Press repeatedly until the menu disappears.
- 4 Take the picture.**
- Press the shutter button fully and keep it pressed to shoot the preset number of pictures. You can stop shooting at any time by releasing the shutter button.



Note

- Sequential shooting (, **HI** , **AF** , **BKT**) is not possible in the following situations:
 - When the TIFF or SHQ record mode is set to ENLARGE SIZE
 - When NOISE REDUCTION is set to ON.
- Auto bracketing is not possible in **M** mode.
- The flash does not fire in **BKT** mode.
- In modes other than **S** and **M**, since the shutter speed is set to max. 1/30 sec., exposure is decreased when shooting a dark subject.
- In **BKT** mode other than **S** mode, if the shutter speed is set to longer than 1/30 sec. when the exposure differential is 0, the shutter speed is fixed at 1/30 sec. and the picture is taken in **BKT** mode.
- If the battery power is low and the battery check blinks during sequential shooting, shooting stops and the camera starts saving the pictures you have taken. Whether or not all of the shots are saved depends on how much battery power remains.
- If there is not enough space available on the card for the number of frames you have set during auto bracketing, you cannot continue shooting.



Self-portrait shooting



Enables you to take a picture of yourself while holding the camera. Point the lens towards yourself and the focus will be locked on you. The camera automatically sets the optimal shooting conditions. The zoom is fixed in the wide position and cannot be changed.

Mode dial



- 1 In the top menu, select **MODE MENU** → **CAMERA** → , and press .

 "How to use the menus" (P.33)

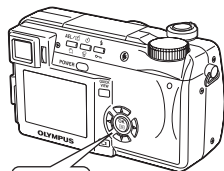

- The self-portrait mode is set.



Arrow pad
OK button

5

- 2 Take the picture.

- Press  to exit self-portrait shooting.
- Press  again to exit the menu.

PANORAMA - Panorama shooting

You can take advantage of panorama shooting with Olympus xD-Picture Card. Panorama shooting lets you connect pictures with overlapping edges into a single panoramic picture, using the CAMELIA Master software.

Mode dial



- 1 In the top menu, select **MODE MENU** → **CAMERA** → **PANORAMA**, and press

"How to use the menus" (P.33)

- The PANORAMA mode is set.

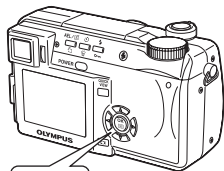

Arrow pad
OK button

- 2 Use the arrow pad to choose at which edge you want to connect the pictures.

- : The next picture is connected at the right edge
- : The next picture is connected at the left edge
- : The next picture is connected at the top
- : The next picture is connected at the bottom

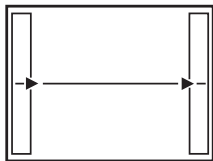

Connects pictures from left to right

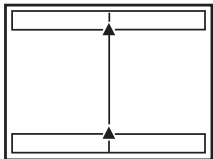

Connects pictures from bottom to top

5

Advanced shooting

3 Make sure that the edge of the pictures overlap, then take pictures.

- Focus, exposure and white balance are set by the first picture. Do not select an extremely bright subject (such as the sun) for the first picture.
- You cannot adjust the zoom after the first picture.
- Panorama shooting is possible for up to 10 pictures.

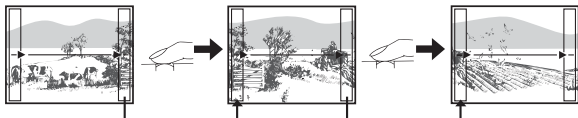

The part of the previous picture where it will be joined to the next picture does not remain in the frame on the edge of the screen. You have to remember what the part in the frame looked like and take the next picture so it overlaps. Compose your shots so that the right edge of the previous picture overlaps with the left edge of the next picture if you are connecting pictures from left to right (or vice versa if you are connecting pictures from right to left).

- When you have taken 10 pictures, a warning mark appears.



4 Press to finish panorama shooting.

- The frame on the screen disappears and the camera returns to the normal shooting mode.



Note

- The panorama mode is only available with Olympus CAMEDIA-brand cards.
- During panorama shooting, the flash and sequential shooting are not available.
- Images are saved in JPEG format when panorama shooting is done in the TIFF mode. The size of the image does not change.
- If the mode dial is operated during panorama shooting, the camera cancels the panorama mode and returns to normal shooting.
- The camera itself cannot connect panorama pictures. The CAMEDIA Master software is necessary to connect the pictures.

This function allows you to combine two pictures taken in succession and store them as a single picture. You can combine two different subjects in one picture.



Picture when played back



- In the top menu, select **MODE MENU** → **CAMERA** → **2 IN 1**, and press .

"How to use the menus" (P.33)

- The 2 IN 1 picture mode is set.



Arrow pad

OK button

- Take the first shot.

- The subject will be positioned on the left in the combined picture.

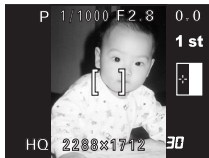

- Take the second shot.

- The subject will be positioned on the right in the combined picture.
- The **BUSY** bar is displayed during processing. After the image is saved, the camera returns to the mode menu.



Image when shot



Note

- During 2 IN 1 picture shooting, the panorama, sequential shooting and self-portrait modes are not available.
- To cancel the 2 IN 1 picture mode after the first shot has been taken, press . The first shot will not be saved.
- Operating the mode dial will exit 2 IN 1 picture mode.
- If the camera enters sleep mode after the first shot, 2 IN 1 picture mode will be canceled.

FUNCTION - Adding special effects to pictures

This feature lets you add special effects to your pictures during shooting. 4 effects are available.

BLACK & WHITE Takes pictures in black and white.

SEPIA Gives pictures a sepia tone.

WHITE BOARD Pictures are in black and white, with black letters on a white background emphasized to make them easier to read.

BLACK BOARD Pictures are in black and white, with white letters on a black background emphasized to make them easier to read.

Mode dial



1 In the top menu, select **MODE MENU** → **CAMERA** → **FUNCTION**, then select a mode and press .

"How to use the menus" (P.33)

- WHITE BOARD and BLACK BOARD are not available in mode.
- Press again to exit the menu.

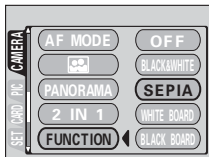
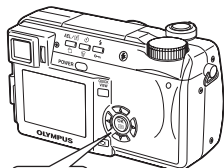

TIPS

Letters do not show clearly with WHITE BOARD or BLACK BOARD.
→ Use exposure compensation. "Exposure compensation" (P.102)



Note

- When WHITE/BLACK BOARD is selected, the flash is automatically set to off.
- WB, and SATURATION cannot be used in Function shooting.

5

Advanced shooting

Recording sound with still pictures



Sound can be recorded when taking still pictures. Recording starts about 0.5 seconds after the shutter is released and lasts about 4 seconds. When this function is enabled, sound is recorded automatically every time you take a picture.

Mode dial



- 1 In the top menu, select **MODE MENU** → **CAMERA** → → **ON**, and press .

“How to use the menus” (P.33)

- Press again to exit the menu.

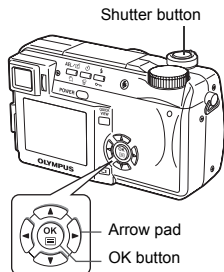

- 2 When recording starts, turn the camera microphone towards the source of the sound you want to record.

- The **BUSY** bar is displayed during recording.

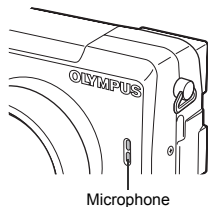



TIPS



- appears on all still pictures and movies that have recorded sound.
- Sound can be added later to still pictures. Recorded sound can also be changed. “Recording sound” (P.127)



Note

- If the camera is more than 1 m (3.3 ft.) away from the source of the sound, sound may not be recorded clearly.
- Pictures cannot be taken during sound recording.
- Sound recording is not possible in the following cases:
 - the record mode is set to TIFF/the drive mode is set to sequential shooting ( , **HI**  , **AF**  , **BKT**)
- Sound recording may also pick up camera noises, such as button operations, shutter movement, etc.
- This camera cannot play back sound.
- Sound recording may not be possible if there is insufficient space in the card memory.



Recording sound with movies



Sound can be recorded while shooting a movie.

Mode dial





- 1 In the top menu, select MODE MENU → CAMERA →  → ON, and press .**

 "How to use the menu" (P.33)

- 2 Recording starts at the same time as shooting.**



Note

- When  is set to ON, the optical zoom position is locked during movie recording. If you wish to use the zoom during movie recording, set DIGITAL ZOOM to ON. If  is set to OFF, you can use both the optical zoom and digital zoom during movie recording.
- If the camera is more than 1 m (3.3 ft.) away from the source of the sound, sound may not be recorded clearly.
- This camera cannot play back sound.

5

Advanced shooting

6 Adjusting the image quality and exposure

Record mode



You can select a record mode in which to take pictures or shoot movies. Choose the best record mode for your purpose (printing, editing on a PC, website editing, etc.). For information on the image size for each record mode and the number of remaining pictures and remaining recording time for the card, see the table on P.98.

Normal image mode

← Image becomes clearer

Application	Compression		Un-compressed	Low compression	High compression
	Resolution				
Select for the print size	2288 × 1712	TIFF		SHQ	HQ
	2048 × 1536				
	1600 × 1200			SQ1 HIGH	SQ1 NORMAL
	1280 × 960				
	1024 × 768				
For small sized prints and website	640 × 480			SQ2 HIGH	SQ2 NORMAL

Number of pixels increases ↑

6

● Resolution

The number of pixels (horizontal × vertical) used when saving an image. If the image will be printed, higher resolutions (larger numbers) are recommended so that the image will be clearer. However, higher resolutions make the file size (amount of data) larger, so the number of pictures that can be saved will be fewer.

● Compression

In record modes other than TIFF, image data are compressed. The higher the compression, the less clear the image will be.

● Resolution and picture size on a computer screen

When a picture is transferred to a computer, the size of the picture on the computer screen varies depending on the computer's monitor setting. For instance, a picture taken in 1024 × 768 resolution is the same size as the screen if you set the picture to 1× when the monitor setting is 1024 × 768. However, if the monitor setting is over 1024 × 768 (such as 1280 × 1024), the picture only takes up part of the screen.

Special record modes

Record mode	Features	Resolution
ENLARGE SIZE (SHQ, HQ)	Increases the resolution. This is useful for printing large-sized prints.	3200 × 2400
3:2 (TIFF, SHQ, HQ)	This is useful for ordering prints from a photo lab.	2288 × 1520

3:2 Resolution

The image aspect ratio is normally 4:3. If the aspect ratio is changed to 3:2, the image can be printed at a photo lab without losing the image borders. The 3:2 aspect ratio setting is not available in **AUTO** or  mode.





Monitor display when **3:2** is set

ENLARGE SIZE

When ENLARGE SIZE is selected, the actual 4 million pixels used by this camera can be increased to the equivalent of approx. 8 million pixels (3200 × 2400). This allows you to make quality prints in larger sizes, such as A3 (297 mm × 420 mm/11.7" × 16.5"). However, file sizes also become larger. ENLARGE SIZE is not available in the **AUTO** or  mode.



Note

- If the SHQ record mode is set to ENLARGE SIZE, sequential shooting modes (, **HI** , **AF** , **BKT**) are not available.

● Record modes and the number of storable still pictures/ remaining recording time

The number of storable still pictures and remaining recording time is also displayed on the monitor when a card is in the camera.



Number of storable still pictures

Still picture record mode

Record mode	Resolution		Compression	File format	Memory capacity in no. of shots			
					16MB			
					With sound	Without sound		
TIFF	2288 × 1712		Uncompressed	TIFF	—	1		
	3:2	2288 × 1520			—	1		
	2048 × 1536				—	1		
	1600 × 1200				—	2		
	1280 × 960				—	4		
	1024 × 768				—	6		
SHQ	2288 × 1712		Low compression	JPEG	5	5		
	3:2	2288 × 1520			6	6		
	ENLARGE SIZE 3200 × 2400				2	2		
HQ	2288 × 1712		High compression	JPEG	15	16		
	3:2	2288 × 1520			17	18		
	ENLARGE SIZE 3200 × 2400				8	8		
SQ1	2048 × 1536	HIGH	*	JPEG	8	8		
		NORMAL			19	20		
	1600 × 1200	HIGH			11	11		
		NORMAL			30	32		
1280 × 960	HIGH	16			17			
	NORMAL	45			49			
SQ2	1024 × 768	HIGH			*	JPEG	25	26
		NORMAL					66	76
	640 × 480	HIGH	58	66				
		NORMAL	124	165				

* HIGH uses low compression/NORMAL uses high compression

Movie Record Modes

Record mode	Resolution	Seconds of remaining recording time (sec.)	
		16MB	
		With sound	Without sound
SHQ	640 × 480 (15 frames/sec.)	17 sec.	17 sec.
HQ	320 × 240 (15 frames/sec.)	46 sec.	48 sec.
SQ	160 × 120 (15 frames/sec.)	186 sec.	211 sec.





Note



- The number of storable still pictures and remaining recording time listed in the table are approximate.
- The number of storable still pictures may change according to the subject or factors like whether print reservations have been made or not. In certain instances, the number of remaining pictures does not change even when you take pictures or stored images are erased.
- If movies are shot with VIDEO OUT set to PAL and the AV cable connected, the movie recording time will differ from the time listed in the Movie Record Modes table.

Selecting a record mode



- 1 In the top menu, select **MODE MENU** → **PICTURE** → , and press .

 "How to use the menus" (P.33)

- If  is displayed on the top menu as a shortcut menu, press the arrow pad in the same direction as the arrow shown next to .

 "SHORT CUT" (P.140)

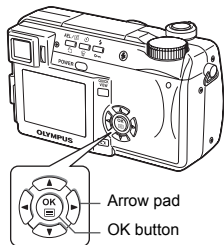

Mode dial

AUTO

In the top menu, press to select , and choose SHQ 2288 × 1712, HQ 2288 × 1712, SQ1 1280 × 960 or SQ2 640 × 480. Go to Step 4.

Mode dial



In the top menu, press to select , then press to select SHQ, HQ or SQ. Go to Step 4.

- 2 Press to select the desired record mode from TIFF, SHQ, HQ, SQ1 and SQ2, then press .

- 3 Press to select the resolution.

If you selected SQ1 or SQ2, press after selecting the resolution, then select HIGH or NORMAL by pressing .

- 4 Press .
 • Press again to exit the menu.

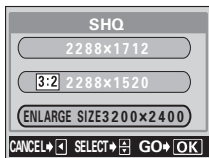

ISO sensitivity

The higher the ISO value, the greater the camera's light sensitivity and the better its ability to shoot in low light conditions. However, higher values also introduce electrical noise into the resulting image, which may give them a grainy appearance.

AUTO

Sensitivity is automatically adjusted according to the light conditions and the subject brightness.

64/100/200/400

With a lower ISO setting, you can shoot clear, sharp images in daylight. With a higher ISO setting, you can use faster shutter speeds with the same amount of light.

Mode dial



- 1 In the top menu, select **MODE MENU** → **CAMERA** → **ISO**, then choose the most suitable **ISO sensitivity and press** .

“How to use the menu” (P.33)

- AUTO is not available in **A/S/M** mode.
- Press again to exit the menu.

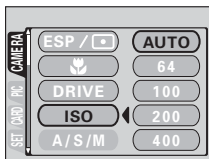
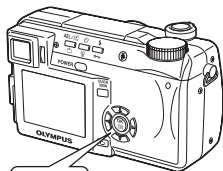

Note

- Higher ISO settings produce more electrical noise.
- When ISO is set to AUTO and you are shooting in dark conditions without a flash, the sensitivity automatically increases, otherwise the shutter speed will be reduced, possibly resulting in camera movement and blurred images.
- If the subject is too far away for the flash illumination to reach when ISO is set to AUTO, the sensitivity is automatically increased.

Exposure compensation



This function allows you to make fine changes to the present exposure setting using the arrow pad. In some situations, you may get better results when the exposure that the camera sets is compensated (adjusted) manually. You can adjust the exposure in the range of ± 2.0 in 1/3 EV steps. When the setting is changed, you can check the result on the monitor or viewfinder.

Mode dial



1 Press to select a setting.

- Adjust toward +: Press to adjust up to +2.0 in 1/3 EV steps.
- Adjust toward -: Press to adjust up to -2.0 in 1/3 EV steps.

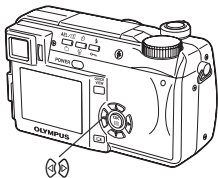

TIPS

- Often bright subjects (such as snow) will turn out darker than their natural colors. Adjusting toward + makes these subjects closer to their real shades. For the same reason, adjust toward - when shooting dark subjects.



Note

- You can set the aperture by pressing in **M** mode. “Manual shooting” (P.68)
- If the flash is used, the image brightness (exposure) may differ from the intended brightness.
- Exposure compensation cannot correct the image if the surroundings of the subject are extremely bright or dark.

Color reproduction differs depending on the light conditions. For instance, when daylight, the setting sun or tungsten lighting are reflected on white paper, the shade of white produced will be slightly different for each. By setting the WB (white balance), you can achieve more natural-looking colors.

Mode dial

- 1 In the top menu, select **MODE MENU** → **PICTURE** → **WB**, and press .

"How to use the menus" (P.33)

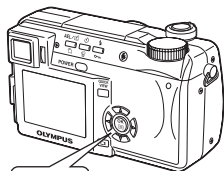
Mode dial

- 1 In the top menu, press to select **WB**.
- 2 Press to select **AUTO**, **PRESET** or according to the shooting conditions.

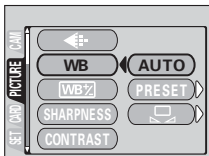

During still picture shooting

AUTO
PRESET



Press . Press again to exit the menu.
Press to display the next selection screen.
 "Preset white balance" (P.104)
Press to display the next selection screen.
 "One-touch white balance" (P.104)

Auto white balance

Automatically adjusts the white balance for any light source.

Preset white balance

Select a preset white balance setting according to the type of light. Press to select one of the following settings, then press .

Press again to exit the menu.

- : For shooting on a sunny day.
- : For shooting on a cloudy day.
- : For shooting under a tungsten light.
- : For shooting under a daylight fluorescent lamp. This type of lamp is used mainly in homes.
- : For shooting under a neutral white fluorescent lamp. This type of lamp is generally used in desk lamps, etc.
- : For shooting under a cool white fluorescent lamp. This type of lamp is generally used in offices, etc.

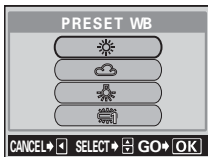

TIPS

- You can also preview different color tones by trying the different PRESET WB settings under the actual light source and checking the result on the monitor.

6

One-touch white balance



This function is useful when you need a more precise white balance than PRESET WB can provide. To set the optimum white balance for the shooting conditions, point the camera at a white object under the light source you want to use and adjust the white balance.

1 Display screen and point the camera at a sheet of white paper.

- Position the paper so that it fills the screen, making sure there are no shadows.



2 Press .

- The white balance is set and the screen returns to the mode menu.
- To cancel one-touch white balance, press .

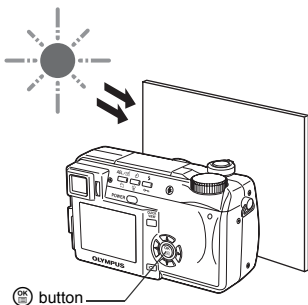

One-touch white balance

3 Press  repeatedly until the menu disappears.

Note

- When setting the white balance by pointing the camera at a sheet of white paper, the correct setting may not be obtained if the light reflected by the paper is too bright or too dark.
- White balance may not be effective under some special light sources.
- After setting a white balance other than AUTO, play back the picture and check the colors on the monitor.
- When the flash is fired with a white balance setting other than AUTO, colors may appear different in the resulting picture from the colors you see on the monitor.

White balance adjustment

WB

This function lets you make fine changes to the current white balance setting.

Mode dial



- 1** In the top menu, select **MODE MENU** → **PICTURE** → **WB**, and press .

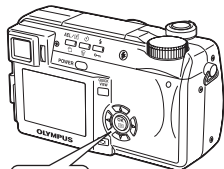

☞ “How to use the menus” (P.33)

- The white balance adjustment indicator appears on the screen.



Arrow pad

OK button

- 2** The color becomes bluer each time you press , and redder each time you press , depending on the original white balance conditions. Press  to save your adjustment.

- The white balance can be adjusted in 7 increments in both red and blue directions.
- After saving the adjustment, press  again to exit the menu.



This function adjusts the sharpness of the image.



- In the top menu, select **MODE MENU** → **PICTURE** → **SHARPNESS**, and press .

"How to use the menus" (P.33)

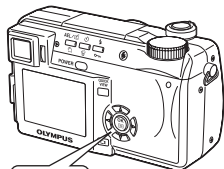

- Press to adjust the sharpness between **+5** and **-5**.

- To increase the sharpness (+) :
Press . The image contours are emphasized, making the image appear sharper and more vivid. Use this setting when you want to print pictures.

- To reduce the sharpness (-) :
Press . The image contours are softened. Use this setting when you want to edit images on a PC.

- When you have finished setting the sharpness, press . Press again to exit the menu.

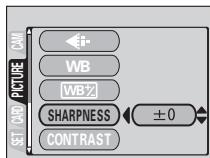

Note

- If you adjust the sharpness too far toward +, noise may become conspicuous in the picture.



This function adjusts the contrast of images. For example, you can make images with marked differences in light and shadow softer, and those with less differences more vivid.

Mode dial



- 1 In the top menu, select **MODE MENU** → **PICTURE** → **CONTRAST**, and press

“How to use the menus” (P.33)

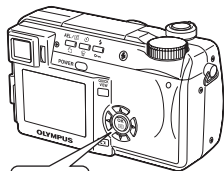

- 2 Press to adjust the contrast between **+5** and **-5**.

- To increase the contrast (+) :

Press . The light and dark areas are defined more clearly, making the image look crisper.

- To reduce the contrast (-) :

Press . The light and dark areas become less defined, giving the image a softer impression. Use this setting when you want to edit images on a PC.

- When you have finished setting the contrast, press . Press again to exit the menu.

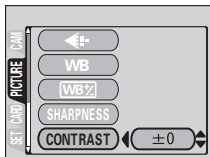

This function adjusts the color depth.

Mode dial



- 1 In the top menu, select **MODE MENU** → **PICTURE** → **SATURATION**, and press

"How to use the menus" (P.33)

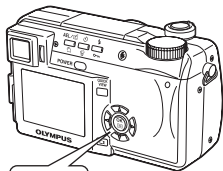

- 2 Press to adjust the saturation between +5 and -5.

- To increase the saturation (+) :
Press . Colors become darker and more intense.
- To reduce the saturation (-) :
Press . Colors become lighter.

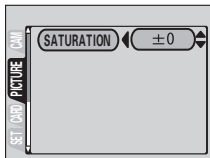

- When you have finished setting the saturation, press . Press again to exit the menu.

This function reduces the noise that is generated during long exposures. When shooting night scenes, shutter speeds become slower and noise tends to appear on images. When noise reduction is set to ON, the camera automatically reduces noise to produce clearer images. However, shooting time is approximately twice as long as usual.

Noise reduction can only be used when the shutter speed is set slower than 1/2 sec.



Noise Reduction: OFF



Noise Reduction: ON

Mode dial



- In the top menu, select **MODE MENU** → **CAMERA** → **NOISE REDUCTION** → **ON** or **OFF**, and press .

“How to use the menus” (P.33)

- Press again to exit the menu.

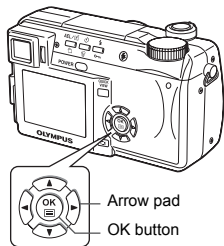

Note

- Noise reduction is always fixed to ON in the mode.
- When noise reduction is set to ON, the camera implements noise-reducing processes after each shot to produce clearer images. However, shooting time is approximately twice as long as usual. During this time, the next shot cannot be taken.
- When noise reduction is set to ON, sequential shooting (, **HI** , **AF** , **BKT**) and 2 IN 1 are not possible.
- This function may not work effectively with some shooting conditions or subjects.
- As the shutter speed is relatively slow, the use of a tripod is recommended.

Histogram display



During shooting and playback of still pictures, you can display a histogram showing the brightness and contrast of your subject in the viewfinder or monitor.

Checking the histogram enables precise exposure control when taking pictures.

During playback, you can display a histogram showing the brightness and contrast of recorded pictures.

The histogram display can be set separately for shooting mode and playback mode.

Ex: When a histogram is displayed in **P** mode

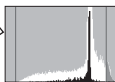

The part indicated in green in the histogram shows the luminance distribution within the AF target mark.

When the image is bright

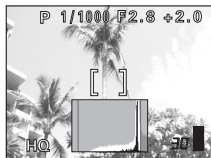

If the peak fills too much of the right frame, the image will appear mostly white.

When the image is dark

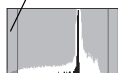
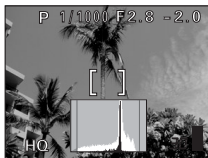

If the peak fills too much of the left frame, the image will appear mostly black.

Mode dial



- 1 In the top menu, select **MODE MENU** → **CAMERA** → → **ON** or **OFF**, and press .

"How to use the menus" (P.33)

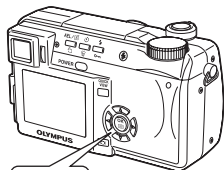

Mode dial



- In the top menu, select **MODE MENU** → **PLAY** → → **ON** or **OFF**, and press .

"How to use the menus" (P.33)

- When ON is selected, the histogram is displayed.
- Press again to exit the menu.

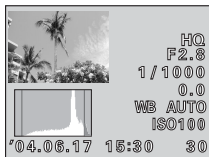

Playback mode



Note

- The histogram is not displayed in the following situations even if histogram display is set to ON.
During **M** mode, panorama shooting, 2 IN 1 shooting, multi-metering and self-portrait
- The histogram displayed during shooting may differ from the histogram displayed during playback.
- A histogram may not appear when you play back pictures shot on another camera.
- A histogram is not displayed in mode.

7 Playback

Viewing still pictures



Mode dial



- 1 Set the mode dial to  and press the power switch.

 "Power on/off" (P.24)

- The monitor turns on and displays the last picture taken. (Single-frame playback)

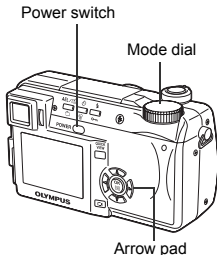

- 2 Use the arrow pad to play back other pictures.

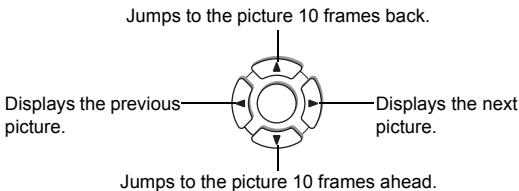

Note

- If the camera is not used for over 3 minutes, the camera enters the sleep mode and the monitor turns off.

QUICK VIEW

This function lets you play back pictures while the camera is in the shooting mode. This is useful when you want to check shooting results and resume shooting quickly.

Functions available in normal playback mode are also available in QUICK VIEW.



1 Press the QUICK VIEW button in the shooting mode.

- The camera immediately enters the playback mode and displays the last picture taken. (Single-frame playback)

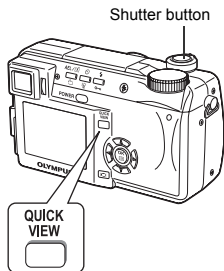

2 Press the QUICK VIEW button again to return to the shooting mode.

- You can also return to the shooting mode when the shutter button is gently pressed.



Pictures displayed on the monitor can be enlarged 1.5, 2, 2.5, 3, 3.5 or 4 times.

Mode dial



1 Select the still picture you want to enlarge.

☞ “Viewing still pictures” (P.113)

- You cannot enlarge pictures with .

2 Pull the zoom lever toward T (Q).

- Each time you pull the zoom lever, the picture is enlarged gradually.
- By using the arrow pad while the enlarged picture is displayed, you can shift the picture in the desired direction, enabling you to view a different portion.
- To return the picture to the original size (1×), push the zoom lever toward W.

Zoom lever

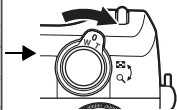
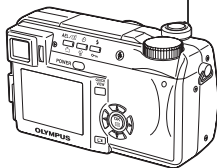

7

Playback



Note

- Pictures cannot be stored in an enlarged state.



This function lets you show several pictures at the same time on the monitor. The number of pictures shown can be 4, 9 or 16. “Selecting the number of pictures” (P.117)

Mode dial



1 In the single-frame playback mode, push the zoom lever toward W

“Viewing still pictures” (P.113)

- Use the arrow pad to select the picture.

: Moves to the previous frame.

: Moves to the next frame.

: Jumps to the previous index display (the frames before the top left frame).

: Jumps to the next index display (the frames following the bottom right frame).

- To return to the single-frame playback, pull the zoom lever toward T.

Zoom lever

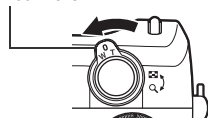

Selecting the number of pictures

This function lets you select the number of pictures in an index display from 4, 9 and 16.

Mode dial



- In the top menu, select **MODE MENU** → **SETUP** → → **4, 9 or 16**, and press .

“How to use the menus” (P.33)

- Press again to exit the menu.

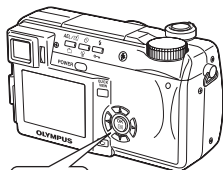

Arrow pad

OK button

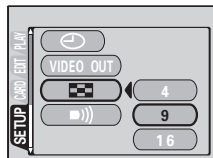

7

Playback

Slideshow



This function displays still pictures stored in the card one after another. Only the first frame of movies is played back.

Mode dial



1 Select a still picture, then press



to display the top menu.

☞ “Viewing still pictures” (P.113)

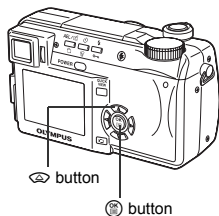

2 Press to start the slideshow.

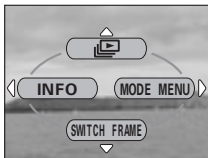

3 Press to stop the slideshow.

- The slideshow will not stop until you cancel it by pressing .



Note

- You are recommended to use the optional AC adapter when running a slideshow for a long period of time. If batteries are used, the camera will enter the sleep mode after about 30 minutes and stop the slideshow automatically.

7

Playback



Mode dial



- 1 Use the arrow pad to display the picture with you want to play back.

“Viewing still pictures” (P.113)

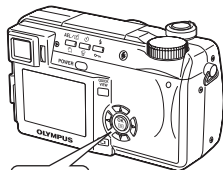

Arrow pad

OK button

- 2 Press .
- 3 Press to select **MOVIE PLAY**.

- 4 Press to select **MOVIE PLAYBACK**, then press .

- The movie is played back. When playback ends, the display automatically returns to the beginning of the movie.

- Fast forward/fast rewind functions are available during playback.

: Fast forward. Each press switches the speed between $\times 1$, $\times 2$ and $\times 20$.

: Fast rewind. Each press switches the speed between $\times 1$, $\times 2$ and $\times 20$.

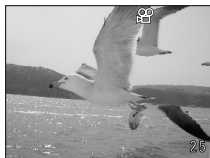

- Press  again after playback ends to display the menu.



PLAYBACK Plays back the entire movie again.

FRAME BY FRAME





Plays back the movie manually one frame at a time.

EXIT Leaves the movie playback mode.



Press   to select PLAYBACK, FRAME BY FRAME or EXIT, then press .

When FRAME BY FRAME is selected

-  : Displays the first frame of the movie.
-  : Displays the last frame of the movie.
-  : Displays the next frame. The movie can be played continuously by holding the button down.
-  : Displays the previous frame. The movie can be played continuously in reverse by holding the button down.
-  : Displays the MOVIE PLAYBACK menu.



TIPS

- Movies can also be played back in the shooting mode using QUICK VIEW.  "QUICK VIEW" (P.114)



Note

- This camera cannot play back sound.
- The card access lamp blinks while the camera is reading the movie from the card. Reading of movies may take considerable time. Do not open the battery compartment/card cover while the card access lamp is blinking, as this may cause not only the data on the card to be damaged, but may also render the card unusable.

Editing movies

This function lets you create indexes as well as edit movies. However, you cannot edit movies of the following lengths:

Movies without sound: Longer than approximately 20 seconds in SHQ mode, 70 seconds in HQ mode, or 300 seconds in SQ mode

Movies with sound: Longer than approximately 20 seconds in SHQ mode, 70 seconds in HQ mode, or 300 seconds in SQ mode

INDEX 9 frames extracted from a movie are displayed as an index to show the movie at a glance. Indexes can be stored on the card as a still picture.

EDIT This function lets you erase parts of the movie that you do not want.

Mode dial



1 Use the arrow pad to select a picture with

"Viewing still pictures" (P.113)

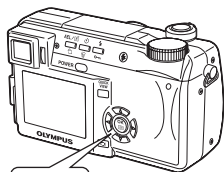

2 In the top menu, select **MOVIE PLAY**, then choose each item.

"How to use the menus" (P.33)

- Select INDEX P.121
- Select EDIT P.123







INDEX - Creating an index

3 Press to select **INDEX**, then press .

- When there is insufficient card memory, a warning screen appears and the display returns to the setting screen.



4 Use the arrow pad to select the first frame of the index and press .



-  : Jumps to the first frame of the movie.
-  : Jumps to the last frame of the movie.
-  : Displays the next frame. The movie can be played continuously by holding the button down.
-  : Displays the previous frame. The movie can be played continuously in reverse by holding the button down.



5 As in Step 4, use the arrow pad to select the last frame of the index and press .



6 Press to select OK, then press .

- The 9 frames extracted from the movie appear as an index display, then the camera returns to the playback mode. The index is stored as a new picture.
- If you want to select different frames, select RESET and press  and repeat the procedure from Step 4.
- To quit the editing function, select CANCEL and press .

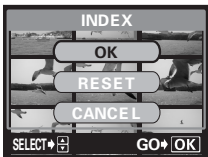

TIPS

- The index is stored as a still picture in a different record mode from the original movie.

Record mode when the movie was shot	Record mode when stored as an index
SHQ	SQ2 (1024 × 768 pixels: HIGH)
HQ	SQ2 (1024 × 768 pixels: HIGH)
SQ	SQ2 (640 × 480 pixels: HIGH)



Note

- The interval between the frames that are automatically picked out varies depending on the length of the movie.
- An index consists of 9 frames.
- You cannot create an index if there is insufficient memory space on the card.

EDIT - Editing a movie

- 3** Press to select EDIT, then press .



- 4** Use the arrow pad to select the first frame of the part you want to keep and press .

: Jumps to the first frame of the movie.

: Jumps to the last frame of the movie.

: Displays the next frame. The movie can be played continuously by holding the button down.

: Displays the previous frame. The movie can be played continuously in reverse by holding the button down.





- 5** As in Step 4, use the arrow pad to select the last frame of the part you want to keep and press .



7

Playback

6 Press to select OK, then press .

- If you want to select different frames, select RESET and press  and repeat the procedure from Step 4.
- To quit the editing function, select CANCEL and press .



7 Press to select NEW FILE or OVERWRITE, then press .

NEW FILE Stores the edited movie as a new movie.

OVERWRITE Stores the edited movie with the same name as the original. The original movie is not stored.



- The edited movie is stored and the screen returns to the playback mode.



Note

- You cannot edit movies with sound which were taken with another digital camera.
- You cannot select NEW FILE if there is insufficient memory space on the card.
- You cannot create an index or edit a movie when the movie is played back setting SWITCH FRAME to .

Playback on a TV

Use the AV cable provided with the camera to play back recorded images on your TV. You can play back both still pictures and movies on your TV. Sounds stored with an image are also played.

Mode dial



- 1 Make sure that the TV and camera are turned off. Connect the A/V OUT jack on the camera to the Video input terminal on the TV using the AV cable.**

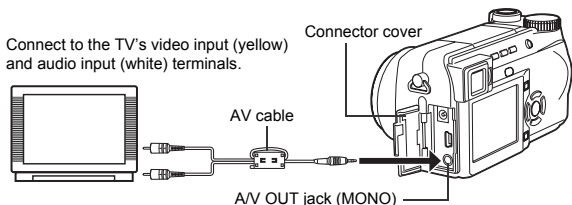

- 2 Turn the TV on and set it to the video input mode.**
 - For details of switching to video input, refer to your TV's instruction manual.
- 3 Set the mode dial to and turn the camera on.**
 - The last picture taken is displayed on the TV. Use the arrow pad to select the picture you want to display.
 - The close-up playback, index display and slideshow functions can also be used on a TV screen.



TIPS

- You are recommended to use the optional AC adapter when using the camera with a TV.



Note

- Make sure that the camera's video output signal type is the same as the TV's video signal type. "VIDEO OUT – Video output selection" (P.157)
- The camera's monitor or viewfinder turns off automatically when the AV cable is connected to the camera.
- Be sure to use the AV cable provided to connect the camera to the TV.
- The picture may appear off-center on the TV screen.

- When pictures are compressed in order to fit the entire picture on the TV screen, a black frame appears around the picture. If the picture is output to a video printer via the TV, the black frame may be printed.

Picture rotation



Pictures taken with the camera held vertically are displayed horizontally. This function lets you turn such pictures 90 degrees counterclockwise or clockwise so that they are displayed vertically.



1 In the single-frame playback mode, press

"Viewing still pictures" (P.113)

- Each pressing rotates the image in the following sequence: 90 degrees counterclockwise, 90 degrees clockwise, and back to the original.

Rotation button

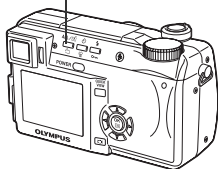

7
Playback

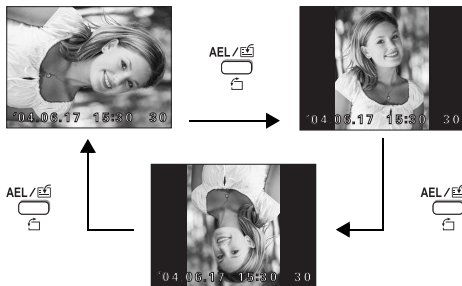

- The following pictures cannot be rotated.
Movies, protected pictures, pictures being played with Pi, pictures that have been edited on a PC, and pictures taken with another camera.
- New picture orientations are saved even when the power is turned off.

Recording sound



Sound can be added to a still picture that you have already taken. (This is known as “after-recording”) You can also re-record over the sound that has already been recorded. Total recording time per picture is approximately 4 seconds.

Mode dial



- 1 Use the arrow pad to select the still picture you want to add sound to.

“Viewing still pictures” (P.113)

- 2 In the top menu, select **MODE MENU** → **PLAY** → .

“How to use the menus” (P.33)

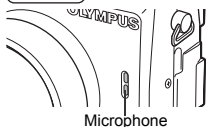
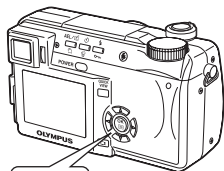

- 3 Press to display **START**.
- 4 Turn the camera microphone toward the sound you want to record and press to start recording.

• The **BUSY** bar is displayed during recording.

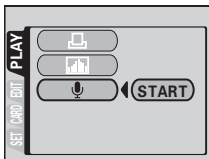

7

Playback





Note

- If the microphone is placed farther than 1 m (3.3 ft.) from the subject, sound may not be recorded properly.
- If you re-record the sound, the original sound is erased.
- You may not be able to record sound when there is insufficient card memory (the “CARD FULL” message is displayed).
- Sound recording may pick up camera noises, such as button operation or shutter movement.
- Once sound is added to a picture, it is not possible to erase only the sound. In this case, make a re-recording with silence.
- This camera cannot play back sound.

Editing still pictures

This function lets you edit still pictures and store them as new pictures. The following editing operations are possible.

Resizing  Changes the picture size to 640 × 480 or 320 × 240 and stores the picture as a new file.

Trimming  Crops part of a picture and saves it as a new file.

Mode dial



- 1 Use the arrow pad to select the still picture you want to edit.
- 2 In the top menu, select **MODE MENU** → **EDIT**, then choose each item.

 “Viewing still pictures” (P.113)

 “How to use the menus” (P.33)



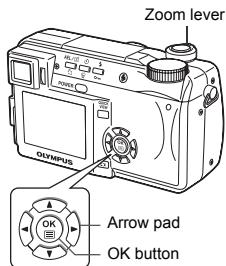

• Select   P.128

• Select   P.129



Resizing



- 3 Select , then press .
- 4 Press   to select the picture size, then press .

- The **BUSY** bar is displayed during resizing. After the image is saved, the camera returns to the playback mode.
- To quit the resizing function, select **CANCEL**, then press .

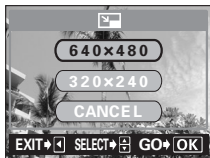

















Note

- Resizing is not possible in the following cases.
 - Movies, pictures that have been edited on a PC, or when there is insufficient memory space on the card.
- If the size of the selected picture is 640 × 480, you cannot select 640 × 480.

Trimming



- 3 Select , then press .
- 4 Press   to select , then press .
- 5 Use the arrow pad and zoom lever to decide the trimming position and size.
 - Press     to move the trimming frame.
 - Use the zoom lever to decide the trimming position size. The trimming frame changes from horizontal to vertical and vice versa when the maximum or minimum size is reached.
- 6 Press .
- 7 Press   to select OK, then press .
 - The **BUSY** bar is displayed during trimming. After the image is saved, the camera returns to the playback mode.
 - The trimmed picture is stored as a separate picture from the original.
 - If you want to trim the picture again, select RESET and press  and repeat the procedure from Step 5.
 - To quit the trimming function, select CANCEL and press .

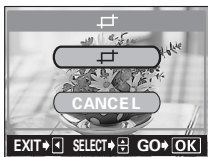

7

Playback



Note

- Trimming is not possible in the following cases.
Movies, when there is insufficient memory space on the card, or when the picture was taken with the record mode set to ENLARGE SIZE
- It may not be possible to trim pictures taken with another camera.
- If a trimmed picture is printed out, it may appear grainy.



You are recommended to protect important pictures to avoid accidentally erasing them. You can play back only protected pictures. “SWITCH FRAME – Playing back only protected pictures” (P.132)
Protected pictures cannot be erased by the single-frame/all-frame erase function.

Mode dial



1 Use the arrow pad to display the picture you want to protect.

“Viewing still pictures” (P.113)

Protect button

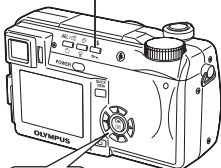

Arrow pad

OK button

2 Press .

- To cancel protection, press again.



Displayed when a picture is protected.

7

Playback



Note

- Protected pictures cannot be erased by the single-frame/all-frame erase function, but they are all erased by formatting.

SWITCH FRAME – Playing back only protected pictures

You can play back only protected pictures.

This can be used to separately manage pictures taken as a travel memo and separate those pictures you want to show to others.

ALL All pictures are played back.

On Only protected pictures are played back.

Mode dial



1 In the top menu, select **SWITCH FRAME** → **On**, and press .

“How to use the menus” (P.33)

- Only protected pictures are played back.
- When **ALL** is selected, all pictures stored in the card are played back.



7

Playback



Note

- Images selected from **On** and played back are protected and cannot be erased. To erase a picture, press **On** to cancel the protection setting, then select **ALL** and erase the desired picture.
- If **On** is pressed during playback of a picture selected from **On**, the protection setting for the displayed picture is canceled and the picture cannot be played back even by selecting **On**.
- If the card is formatted, all of the pictures on the card will be erased.
- Images selected from **On** and played back cannot be rotated.
 “Picture rotation” (P.126)

Erasing pictures



This function erases recorded pictures. Pictures can be erased either one frame at a time or all the pictures in the card.



Note

- You cannot erase protected pictures. Cancel protection before erasing such pictures.
- Pictures played back with cannot be deleted.
 "SWITCH FRAME – Playing back only protected pictures" (P.132)
- Once erased, pictures cannot be restored. Check each picture before erasing to avoid accidentally erasing pictures you want to keep. "Protecting pictures" (P.131)

Single-frame erase



Mode dial



- 1 Use the arrow pad to display the picture you want to erase.
 "Viewing still pictures" (P.113)

Erase button

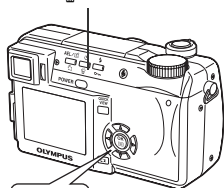

Arrow pad

OK button

7

Playback

- 2 Press .
 - The ERASE screen is displayed.
 - 3 Press to select YES, then press .
- The picture is erased and the menu is closed.



All-frame erase



This function erases all the pictures on the card.

Mode dial



- 1** In the top menu, select **MODE MENU** → **CARD** → **CARD SETUP** and press .

☞ “How to use the menus” (P.33)

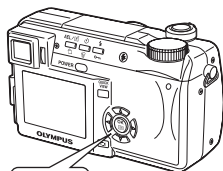



Arrow pad

OK button

- 2** Press   to select  **ALL ERASE**, then press .



- 3** Press   to select **YES**, then press .

• All the pictures are erased.



8 Useful functions

ALL RESET - Saving the camera's settings

This function lets you choose whether or not to save the current camera settings after the power is turned off. The settings affected by ALL RESET are listed on the next page.

The All Reset setting (ON/OFF) applies to all the modes. If ALL RESET is set to OFF in one shooting mode, this setting applies to all the other modes, both shooting and playback.

ON All settings are returned to the factory default settings after the power is turned off. (Factory default settings)

Example: If ALL RESET is set to ON and the record mode is changed to SQ1, the record mode returns to the default factory setting (HQ) when the camera is turned on again.

OFF The settings made before the power is turned off are saved.



- 1 In the top menu, select **MODE MENU** → **SETUP** → **ALL RESET** → **OFF** or **ON**, and press .

"How to use the menus" (P.33)



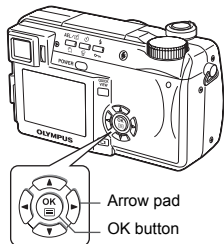









- Press again to exit the menu.



Note

- MY MODE settings and the settings in the SETUP tab in the MODE MENU (ALL RESET,) etc.) are saved even when ALL RESET is set to ON.

● Functions that All Reset ON setting affects

Function	Factory default setting	Ref. Page	Function	Factory default setting	Ref. Page
F No	F2.8	P.66	FULLTIME AF	OFF	P.71
SHUTTER	1/1000	P.67	AF MODE	iESP	P.70
	0.0	P.102	FUNCTION	OFF	P.93
FLASH MODE	AUTO	P.57	INFO	OFF	P.148
	0.0	P.64	 (still pictures)	OFF	P.111
AF/MF	AF	P.75	 (movies)	OFF	P.94
	OFF	P.84	SUPER ZOOM	OFF	P.95
LCD*	ON (lights)	—	 HQ	OFF	P.55
OPTICAL ZOOM	38mm	P.54	White balance	HQ	P.96
ESP/ 	ESP	P.77		AUTO	P.103
	OFF	P.82	SHARPNESS	None	P.106
DRIVE		P.85	CONTRAST	±0	P.107
BKT	±1.0, 3 pictures	P.86	SATURATION	±0	P.108
ISO	AUTO/64	P.101	TIFF, SHQ, HQ	±0	P.109
A/S/M	A	P.65	SQ1	2288 × 1712	P.98
 SLOW	 SLOW1	P.63	SQ2	1280 × 960 NORMAL	P.98
NOISE REDUCTION	OFF	P.110	INFO	640 × 480 NORMAL	P.98
DIGITAL ZOOM	OFF	P.56	INFO	OFF	P.148

* This sets whether the monitor turns on or not when the camera is turned on.









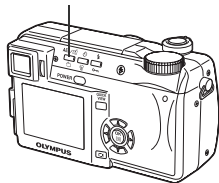













CUSTOM BUTTON



Functions listed in the table below can be assigned to the custom button on the camera. This makes it easy to jump to frequently used functions simply by pressing the custom button without having to select a shortcut menu or MODE MENU from the top menu.

AEL /  AE Lock/Custom button



Available functions	Settings	Ref. Page
AE LOCK (factory default setting)	—	P.80
AF LOCK	—	P.73
	ESP, 	P.77
	OFF,  , 	P.82
DRIVE	 ,  , HI  , AF  , BKT	P.85
ISO	AUTO, 64, 100, 200, 400	P.101
A/S/M	A, S, M	P.65
 SLOW	 SLOW1,   SLOW1,  SLOW2	P.63
NOISE REDUCTION	OFF, ON	P.110
DIGITAL ZOOM	OFF, ON	P.56
FULLTIME AF	OFF, ON	P.71
AF MODE	iESP, SPOT	P.70
FUNCTION	OFF, BLACK & WHITE, SEPIA, WHITE BOARD, BLACK BOARD	P.93
INFO	OFF, ON	P.148
	OFF, ON	P.111
	TIFF, SHQ, HQ, SQ1, SQ2	P.96
WB	AUTO,  ,  ,  ,  ,  , 	P.103
 (still pictures)	OFF, ON	P.94
SUPER ZOOM	OFF, ON	P.55

Setting the custom button

Mode dial



A/S/M P

- 1 In the top menu, select **MODE MENU** → **SETUP** → **CUSTOM BUTTON**, and press

• Press “How to use the menus” (P.33)



Arrow pad

OK button

- 2 Press to select a function, then press .

• Press again to exit the menu.



Using the custom button

Mode dial



1 Press AEL/☒.

- The monitor turns on and the function currently set to the custom button appears.

AEL/☒ AE Lock/Custom button

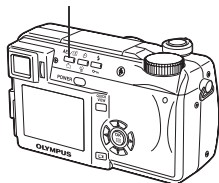

Ex: When DRIVE is set on the custom button

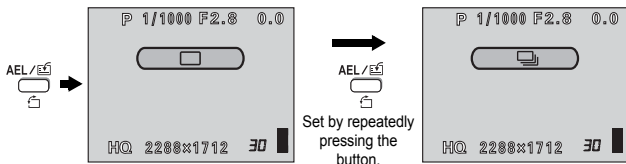

TIPS

When ISO is set to the custom button but you want to use AE lock

- The AE lock function cannot be used when a different function is set to the custom button. Reset AE lock to the custom button by following "Setting the custom button" (P.138).



Note

- You cannot set the custom button separately in each mode.

SHORT CUT

You can set three shortcut menus (A, B, C) on the top menu in a still picture shooting mode (except **AUTO**).

This is useful when you want to go quickly to frequently used functions.

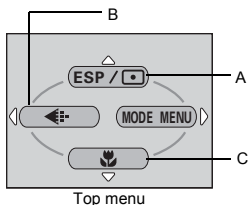

Default setting

A: ESP/[ESP icon]

B: [Left arrow icon]

C: [Flower icon]

Functions that can be set in the shortcut menu	Ref. Page	Functions that can be set in the shortcut menu	Ref. Page
ESP/[ESP icon]	P.77	PANORAMA	P.89
[Flower icon]	P.82	2 IN 1	P.91
DRIVE	P.85	FUNCTION	P.93
ISO	P.101	AF AREA	P.72
A/S/M	P.65	INFO	P.148
[My] 1/2/3/4	P.69	[Histogram icon]	P.111
[Zoom icon]	P.64	[Left arrow icon]	P.96
[Lightning bolt icon] SLOW	P.63	WB	P.103
NOISE REDUCTION	P.110	[WB icon]	P.106
DIGITAL ZOOM	P.56	SHARPNESS	P.107
FULLTIME AF	P.71	CONTRAST	P.108
AF MODE	P.70	SATURATION	P.109
[Camera icon]	P.88	[Microphone icon] (still pictures)	P.94
		SUPER ZOOM	P.55

Setting the shortcut menu

You can set the three shortcut menus designated by A, B and C on the diagram shown right.

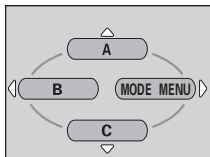

Mode dial



- 1** In the top menu, select **MODE MENU** → **SETUP** → **SHORT CUT**, and press

"How to use the menus" (P.33)

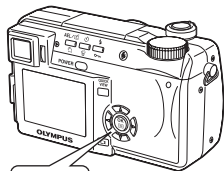

- 2** Press to select A, B or C, then press .

- 3** Press to select a function, then press .

- The shortcut menu is set.
- Press again to exit the menu.

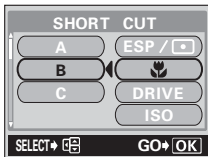
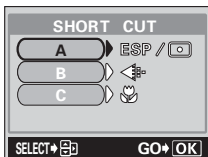

Using the shortcut menu

When you have set a shortcut menu, you can use it to jump to the setting screen for that function.



1 Press to display the top menu.

- The shortcut menu you have set appears on the top menu.

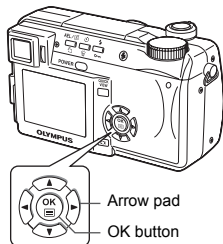

2 Press or to select the shortcut menu.

- The monitor jumps directly to the setting screen for that function.

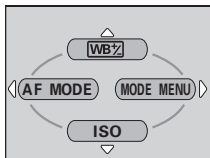

Ex: When **WB** is set in shortcut menu A

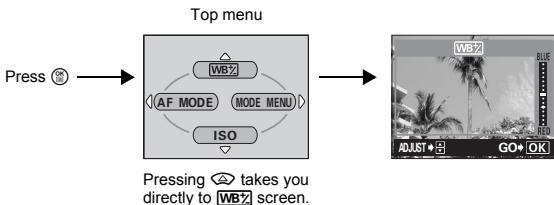

Note

- You cannot set the custom button separately in each mode.

MY MODE SETUP



You can set shooting-related functions in MY MODE. When the camera is in P, A, S or M mode, you can also save the current settings in MY MODE. When the mode dial is set to , your customized settings are activated. You can save up to 4 different settings in MY MODE 1 to 4. Only MY MODE 1 has a factory default setting.ⁱ

● Functions affected by MY MODE SETUP

Functions that can be set in MY MODE	Default setting	Ref. Page	Functions that can be set in MY MODE	Default setting	Ref. Page
P/A/S/M/S-Prg	P	P.43	DIGITAL ZOOM	OFF	P.56
FNo	F 2.8	P.66	FULLTIME AF	OFF	P.71
SHUTTER	1/1000	P.67	AF MODE	iESP	P.70
	0.0	P.102		OFF	P.88
LCD *1	ON	—	PANORAMA	OFF	P.89
ZOOM *2	38mm	—	2 IN 1	OFF	P.91
FLASH MODE	AUTO	P.57	FUNCTION	OFF	P.93
	OFF	P.84	INFO	OFF	P.148
AF/MF	AF	P.75		OFF	P.111
ESP/	ESP	P.77		HQ	P.96
	OFF	P.82	WB	AUTO	P.103
DRIVE		P.85		None	P.106
ISO	AUTO	P.101	SHARPNESS	±0	P.107
	0.0	P.64	CONTRAST	±0	P.108
	SLOW1	P.63	SATURATION	±0	P.109
NOISE REDUCTION	OFF	P.110	(still pictures)	OFF	P.94
			SUPER ZOOM	OFF	P.55

*1 This will set the monitor to ON or OFF when the camera is turned on.

*2 In the mode, available zoom positions are 38mm/50mm/100mm/200mm and 380mm (these numbers are based on the focal length of a 35mm camera).

Mode dial



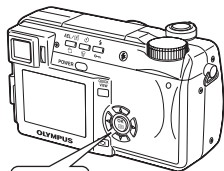

- 1 In the top menu, select **MODE MENU** → **SETUP** → **MY MODE SETUP**, and press .

 "How to use the menus" (P.33)



Arrow pad

OK button

- 2 Press   to select the type of setting, then press .

CURRENT Saves the current camera settings.



RESET Restores the factory default settings.

CUSTOM Saves settings one by one.

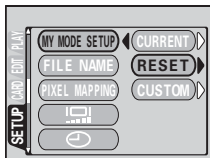
- The MY MODE SETUP screen appears.



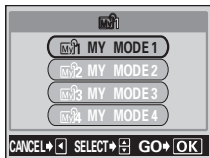

- 3 Select a **MY MODE** number.

- Press   to select MY MODE number from 1 to 4, then press .



●When selecting CURRENT in Step 2

- 4 Press   to select SET, then press .

- The current camera settings are saved in the selected MY MODE.

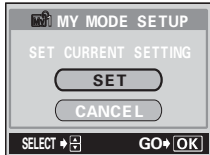

●When selecting RESET in Step 2

4 Press to select ALL RESET, then press .

- The settings in the selected MY MODE are reset.
If no settings are saved, MY MODE settings cannot be selected.

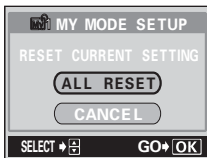

●When selecting CUSTOM in Step 2

4 Press to select the item you want to save in MY MODE, then press .

- For the available items, see "Functions affected by MY MODE SETUP" (P.143).

Press to change the setting, then press .

- The setting is saved.
- You can also change the other custom settings.

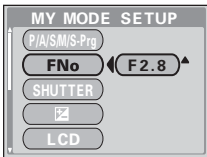
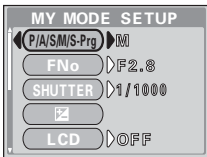

5 When you have made all the settings you want, press .

- The screen displayed in Step 2 appears.
- Press  again to exit the menu.



Note

- Although the settings you are using can be saved, the zoom position you are currently using may not be saved. The zoom position will be the closest of the 5 zoom settings in MY MODE to the position currently being used.

CARD SETUP – Formatting cards



This function lets you format a card. Formatting prepares cards to receive data. Before using non-Olympus cards or cards which have been formatted on a PC, you must format them with this camera.

All existing data, including protected pictures, are erased when the card is formatted. Make sure that you save or transfer important data to a PC before formatting a card.

Mode dial



- 1 In the top menu, select **MODE MENU** → **CARD** → **CARD SETUP**, and press

“How to use the menus” (P.33)

- The **FORMAT** screen is displayed.

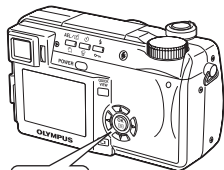

Arrow pad

OK button

Mode dial

AUTO

In the top menu, press to select **CARD SETUP**.

Mode dial



In the top menu, select **MODE MENU** → **CARD** → **CARD SETUP**, and press . Press to select **FORMAT**, then press .

“How to use the menus” (P.33)

8

Useful functions

2 Press to select YES, then press



- The **BUSY** bar is displayed and the card is formatted.

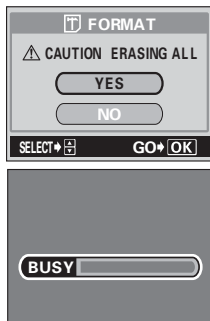

Note

- Never do the following during formatting, as they may cause the card to malfunction.
 Open the battery compartment/card cover. Remove the battery.
 Connect or disconnect the AC adapter.

This function lets you display detailed shooting information on the monitor for approx. 3 seconds in the playback mode. For details of the information displayed, see “Viewfinder and monitor indications” (P.12).

Mode dial

- In the top menu, select **MODE MENU** → **CAMERA** → **INFO** → **ON** or **OFF**, and press .

“How to use the menus” (P.33)

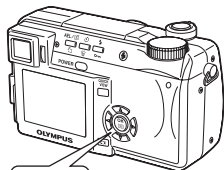

Arrow pad

OK button

Mode dial

Pressing in the top menu displays the full amount of shooting information on the monitor (**ON**).

- To turn INFO off, press to display the top menu and press again.

Ex. Playback mode

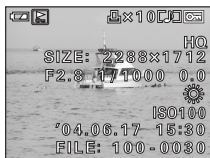

When INFO is ON



When INFO is OFF

Note

- If the picture has been taken with a different camera, setting INFO to ON in mode may still not display all the information.
- If is set, the histogram is displayed regardless of whether INFO is set to ON or OFF.
- If you are using a print service without DPOF, the specified file numbers are displayed when INFO is set to ON in mode.
 “How to print pictures” (P.158)

Monitor/viewfinder brightness adjustment



This function lets you adjust the brightness of the monitor and viewfinder respectively.

Mode dial



- 1 In the top menu, select **MODE MENU** → **SETUP** → , and press





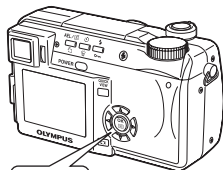



☞ “How to use the menus” (P.33)



Arrow pad

OK button

- 2 Press   to adjust the brightness while looking in the monitor or viewfinder, and when you have set the desired level, press .

- Pressing  brightens the monitor or viewfinder, and pressing  darkens it.
- Press  again to exit the menu.



REC VIEW

You can choose whether or not to display the picture you have just taken on the monitor.

- ON** The picture being recorded to the card is displayed. This is useful for making a brief check of the picture you have just taken. Pressing the shutter button halfway during Rec View lets you resume shooting immediately.
- OFF** The picture being recorded to the card is not displayed. This is useful when you want to prepare for your next shot while the previous picture is being recorded.

Mode dial



- 1** In the top menu, select **MODE MENU** → **SETUP** → **REC VIEW** → **OFF** or **ON**, and press .

 “How to use the menu” (P.33)

- Press  again to exit the menu.

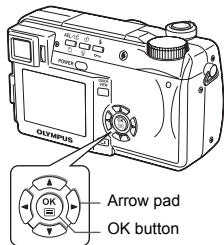

SLEEP - Sleep Timer

The camera automatically enters the sleep mode and stops the operation when the preset time has elapsed with no operations performed. The camera activates again as soon as you touch the shutter button or arrow pad.

Mode dial



- 1 In the top menu, select **MODE MENU** → **SETUP** → **SLEEP** → **30 SEC**, **1 MIN**, **3 MIN**, **5 MIN** or **10 MIN**, and press

"How to use the menus" (P.33)

- Press again to exit the menu.

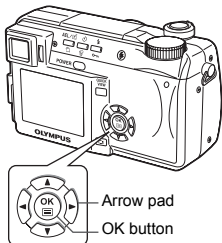

Note

- The sleep mode is not activated when using the AC adapter.
- In mode, the sleep mode is activated after 3 minutes regardless of the setting and the monitor turns off.
- If a slideshow lasts more than 30 minutes, the camera automatically enters the sleep mode and the monitor turns off.



You can turn off the beep sound for button operations and warnings.

Mode dial



- In the top menu, select **MODE MENU** → **SETUP** → **■||)** → **OFF** or **ON**, and press .

"How to use the menus" (P.33)

- Press again to exit the menu.

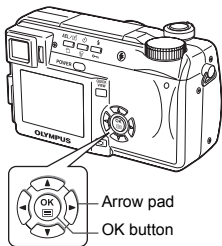

POWER ON/OFF SETUP – Power on/off display setting

You can set your favorite picture to be displayed when the power is turned on and off. It is also possible to register your favorite picture. "SCREEN SETUP" (P.153)

OFF No picture is displayed.

- Factory default setting
- Selects a picture already registered. If there is no picture registered, nothing is displayed when the power is turned on or off.

Mode dial



- In the top menu, select **MODE MENU** → **SETUP** → **PW ON/OFF SETUP** → **OFF**, **1** or **2**, and press .

"How to use the menus" (P.33)

- Press again to exit the menu.

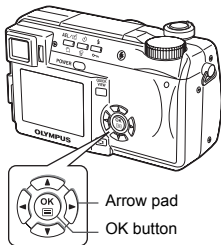

SCREEN SETUP

You can register your favorite picture to be displayed when the power is turned on and off. The desired picture can be registered from the card. Make the POWER ON/OFF SETUP to display the registered picture.

☞ “POWER ON/OFF SETUP – Power on/off display setting” (P.152)

Mode dial



1 In the top menu, select **MODE MENU** → **SETUP** → **SCREEN SETUP**, and press .

☞ “How to use the menus” (P.33)

- If a picture is already registered, the IMAGE EXISTING screen is displayed asking if you want to cancel the currently registered picture and register a new one. To register a new picture, select RESET and press . If you select KEEP, the screen returns to the menu.

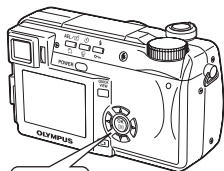

Arrow pad
OK button

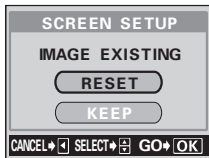

2 Select the picture you want to register using the arrow pad and press .

3 Press to select OK, then press .

- The picture is registered and the screen returns to the menu.
- Press again to exit the menu.

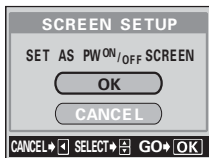

- You cannot register pictures and movie frames that cannot be played back on this camera.

FILE NAME

The camera automatically creates file names and folder names for images to be stored in. Files can be numbered from 0001 to 9999 and folders can be numbered from 100 to 999. Examples are shown below.

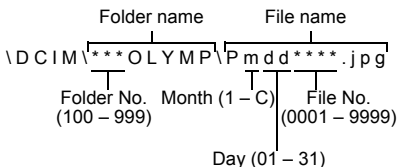

- Month: Jan. - Sep. = 1 - 9, Oct. = A, Nov. = B, Dec. = C

There are two settings from which you can choose: RESET or AUTO. Choose the one that is best for you when transferring images to a PC.

File name settings

RESET The file number and folder number are reset every time a new card is inserted in the camera. The folder number returns to No. 100 and the file number returns to No. 0001. This method is useful when grouping files on separate cards.

AUTO Even if a new card is inserted, the folder number and file number are retained from the previous card, so the same file number is not used on different cards. This helps you to manage multiple cards. This method is useful when you want to manage all your files with sequential numbers.

8

Useful functions

Mode dial



- 1 In the top menu, select **MODE MENU** → **SETUP** → **FILE NAME** → **RESET** or **AUTO**, and press

"How to use the menus" (P.33)

- Press again to exit the menu.

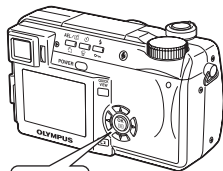



Note

- When the File No. reaches 9999, the file number returns to 0001 and the folder number changes.
- When both the Folder and File No. reach their respective maximum number (999/9999), the number of storable pictures becomes 0 even if the card is not full. No more pictures can be taken. Replace the card with a new one.

PIXEL MAPPING

The Pixel Mapping feature allows the camera to check and adjust the CCD and image processing functions. It is not necessary to operate this function frequently. Approximately once a year is recommended. Wait at least one minute after taking or viewing pictures to allow for proper performance of the Pixel Mapping function.

Mode dial



- 1 In the top menu, select MODE MENU → SETUP → PIXEL MAPPING, and press .**

 "How to use the menus" (P.33)

- START appears.

- 2 Press .**

- The **BUSY** bar is displayed during Pixel Mapping. When Pixel Mapping is finished, the screen returns to the mode menu.

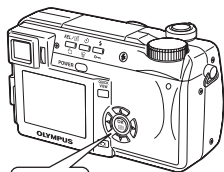

Note

- If you accidentally turn the camera off during Pixel Mapping, start again from Step 1.

The measurement unit can be selected from either meters or feet in the manual focus mode.

- m** At long ranges, the camera measures in meters, and at short ranges in centimeters.
- ft** At long ranges, the camera measures in feet, and at short ranges in inches.

Mode dial



- 1** In the top menu, select **MODE MENU** → **SETUP** → **m/ft** → **m** or **ft**, and press

“How to use the menus” (P.33)

- Press again to exit the menu.

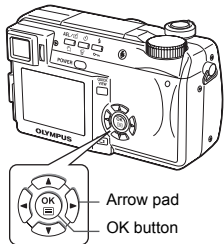



VIDEO OUT – Video output selection

You can select NTSC or PAL according to your TV's video signal type. When playing back pictures while connected to a TV in a foreign country, be sure to set the VIDEO OUT setting accordingly. Select the video signal type before connecting the AV cable. If you select the wrong video signal type, you will not be able to play back the recorded pictures properly on the TV.

Mode dial



- 1 In the top menu, select **MODE MENU** → **SETUP** → **VIDEO OUT** → **NTSC or PAL**, and press .

 "How to use the menus" (P.33)

- Press  again to exit the menu.

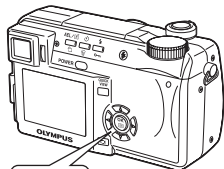

Arrow pad
OK button



TIPS

TV video signal types & main regions

Check the video signal type before connecting the camera.

NTSC Japan, Taiwan, Korea, North America

PAL European countries, China

9 Print setting (DPOF)

How to print pictures



Print reservation allows you to save printing data (the number of prints and the date/time information) with the pictures stored on the card.

With print reservation, you can print out pictures easily either at home using a personal DPOF-compatible printer or at a print shop that supports DPOF. DPOF is a standard format used to record automatic print information from digital cameras. You can print out pictures automatically, at home or in a print shop, by storing such data as which pictures you wish to print and the number of prints on a card.

Pictures taken with print reservation can be printed using the following procedures.

Printing using a DPOF-compatible print shop.

You can print the pictures using the print reservation data.

Printing using a DPOF-compatible printer.

Printing is possible directly from a card containing print reservation data without using a PC. For more details, refer to the printer's instruction manual. A PC card adapter may also be necessary.

**TIPS** - - - - -**Picture size and printing**



The resolution of a computer/printer is generally based on the number of dots (pixels) per square inch. This is called dpi (dots per inch). The higher the dpi value, the better the printed results. Keep in mind, however, that the dpi of the picture does not change. This means that when you print an image with a higher resolution, the size of the printed picture will be smaller. Although you can print magnified images, picture quality will decrease.

If you want to print large, high-quality pictures, set the record mode as high as possible when taking the pictures.

"Record mode" (P.96)



Note

- DPOF reservations set by another device cannot be changed by this camera. Make changes using the original device.
- If a card contains DPOF reservations set by another device, entering reservations using this camera may overwrite the previous reservations.
- If there is not enough space in the card memory, you may not be able to enter the reservation data. CARD FULL will be displayed.
- You can make DPOF print reservations for up to 999 images per card.
- Even if an image appears with the message "PICTURE ERROR", it may be possible to make print reservations. In this case, the print reservation icon () does not appear when the image is displayed for full view.  appears when multiple images are displayed (index display), allowing you to confirm the print reservation.
- Not all functions may be available on all printers, at all print shops, or at all photo labs.
- Some TIFF images cannot be printed.
- Print reservation may take considerable time when saving printing data to a card.

All-frame reservation



Use this feature to print all the pictures stored on the card. Select the desired number of prints and whether you want the date and time included.

Mode dial



1 Play back a still picture.

- ▶ “Viewing still pictures” (P.113)
- You cannot make the print reservation for pictures with



2 In the top menu, select **MODE MENU** → **PLAY** → , and press .

- ▶ “How to use the menus” (P.33)

- If print reservation data is already stored on the card, the  PRINT ORDER SETTING screen appears, giving you the choice of resetting the data or keeping it.

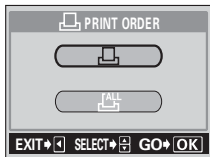

3 Press to select , then press .

4 Press to select × (number of prints) or (date/time), then press .

5 Perform each setting as illustrated.

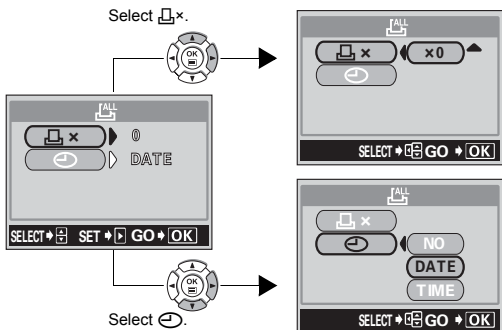

●Set the number of prints

Press to set the number of prints, then press .

: Increases the number.

: Decreases the number.

●Set the date/time printing data

Press to select NO, DATE or TIME, then press .

NO The pictures are printed without the date and time.

DATE All the pictures are printed with the shooting date.

TIME All the pictures are printed with the shooting time.

- After completing all the print reservations, press to return to the menu screen.

Single-frame reservation



Use this feature to print only selected pictures. Display the picture to be printed and select the desired number of prints.

Mode dial



1 Play back a still picture.

- ▶ “Viewing still pictures” (P.113)
- You cannot make the print reservation for pictures with



2 In the top menu, select **MODE MENU** → **PLAY** → , and press .

- ▶ “How to use the menus” (P.33)

- If data is already stored on the card, the PRINT ORDER SETTING screen appears, giving you the choice of resetting the data or keeping it.

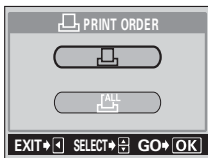

3 Press to select , then press .

4 Select the frame you want to print using the arrow pad and press .



5 Select the appropriate item using the arrow pad.

MORE Sets the number of prints, date/time and trim size. The print reservation data is set and the screen proceeds to Step 6.

SINGLE PRINT Sets single-frame print. The date/time and trimming settings are not available. → Go to Step 9.

CANCEL Cancels the print reservation for the displayed picture. "Resetting print reservation data" (P.167)

END Completes the print reservation. → Go to Step 11.



Single-frame reservation menu

6 Press to select x (number of prints), (date/time) or (trimming), then press .

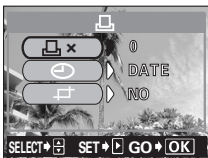

7 Perform each setting.

●Set the number of prints

Press to set the desired number of prints, then press .

: Increases the number.

: Decreases the number.



●Set the date/time printing data

Press to select NO, DATE or TIME, then press .

NO The pictures are printed without the date and time.

DATE All the selected pictures are printed with the shooting date.

TIME All the selected pictures are printed with the shooting time.

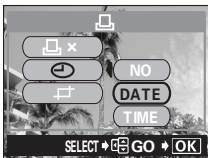

● Trim the picture

☞ “Trimming” (P.165)

- 8** After setting the number of prints and date/time printing data and trimming the picture, press  to complete the print reservations and return to the screen in Step 4.

- The  icon appears on the displayed picture.
- Repeat Steps 4 to 8 to make print reservations for other images.

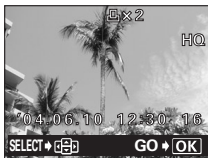



- 9** Press  to display the single-frame reservation menu.

- 10** Press  to select END.

- The  PRINT ORDER screen appears.



- 11** Press  again to display the  PRINT ORDER SETTING screen, then press  once more to complete the print reservations.



This function enables you to crop part of a recorded picture and print out the enlarged section only.

Mode dial



- 1 Press on the single-frame reservation screen to select (trimming) and press .

"Single-frame reservation" (P.162)

- If trimming has already been set, the screen appears. Press to select RESET, then press .



- 2 Use the arrow pad and zoom lever to decide the trimming position and size.

- Press to move the trimming frame.
- Use the zoom lever to decide the trimming size. The trimming frame changes from horizontal to vertical and vice versa when the maximum or minimum size is reached.

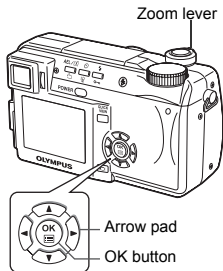

- 3 Press .



4 Press to select OK, then press .

OK Saves the current trimming size and returns to the single-frame reservation screen.



RESET Sets a new trimming size.
→ Go to Step 2.

CANCEL Cancels the current trimming setting and returns to the single-frame reservation screen.



5 Press to complete the print reservations and return to the picture selection screen. Press again.

6 Press to select END.

- The  PRINT ORDER screen appears.
- Press  repeatedly until the playback screen appears.



Note

- The size of the printed picture varies depending on the printer settings. If the trimmed picture size is small, printing magnification increases accordingly, resulting in a printed picture with lower resolution.
- For best results with trimmed pictures, you are recommended to use the TIFF, SHQ or HQ mode.
- The original picture is not trimmed. If your printer does not have the trimming function, the picture will be printed untrimmed.
- Do not rotate pictures that have been trimmed, otherwise the cropped area will change.
- If images recorded in 3:2 are trimmed, the ratio is fixed at 4:3.

Resetting print reservation data



This function allows you to reset the print reservation data for pictures stored on the card.

You can reset all the print reservation data or just for selected pictures.



● To reset the print reservation data for all the pictures

Mode dial



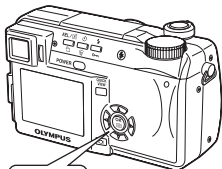

- 1 In the top menu, select **MODE MENU** → **PLAY** → , and press .
 “How to use the menus” (P.33)



- 2 Press  to select **RESET**, then press .

 - If there is no print reservation data stored on the card, the  **PRINT ORDER SETTING** screen does not appear.



- 3 Press  to return to the mode menu.
 - Press  again to exit the menu.



● To reset the print reservation data for a selected picture

Mode dial



- 1** In the top menu, select **MODE MENU** → **PLAY** → , and press .

 "How to use the menus" (P.33)

- 2** Press   to select **KEEP**, then press .

- If there is no print reservation data stored on the card, the  **PRINT ORDER SETTING** screen does not appear.



- 3** Press   to select , then press .

- 4** Select the frame for which you want to reset the print reservation using the arrow pad and press .

- The single-frame reservation menu is displayed.



- 5** Press  to select **CANCEL**.



- The print reservation data is canceled and the screen returns to Step 4.

- 6** If you are finished resetting print reservation data, press .

- The single-frame reservation menu is displayed.



- 7** Press .



- Press  repeatedly until the menu screen appears. Press  again to exit the menu.

10 Direct printing (PictBridge)

Using the direct printing function

By connecting the camera to a PictBridge-compatible printer with the USB cable, you can print out recorded pictures directly. With the camera connected to the printer, select the pictures you want to print and the number of prints on the camera's monitor. It is also possible to print out pictures using the print reservation data.  "Print setting (DPOF)" (P.158)
To find out if your printer is compatible with PictBridge, refer to the printer's instruction manual.

What is PictBridge? ... It is the standard for connecting digital cameras and printers of different makers and printing out pictures directly.

 **STANDARD** ... All printers that support PictBridge have standard print settings. Selecting  STANDARD on the settings screens ( P.174 to 180), images are printed according to this settings. See the instruction manual for your printer for its standard settings or inquire with the printer manufacturers.



TIPS

- For details of printing paper types, ink cassettes, etc., refer to the printer's instruction manual.



Note

- You are recommended to use the optional AC adapter when printing pictures. If you use the battery, make sure that it is fully charged. If the camera stops operating while communicating with the printer, the printer may malfunction or image data may be lost.
- Images recorded in movie mode cannot be printed.
- The camera will not enter sleep mode when connected to the USB cable.

Connecting the camera to a printer

Use the USB cable provided to connect the camera to a PictBridge-compatible printer.

- 1 Turn the printer on and plug the printer end of the USB cable into the printer's USB port.

- For details of how to turn the printer on and the position of the USB port, refer to the printer's instruction manual.

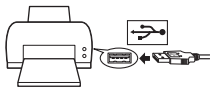



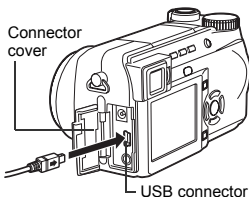

- 2 Set the camera's mode dial to  and plug the USB cable into the camera's USB connector.

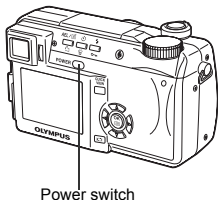

- 3 Press the power switch to turn the camera on.

- The monitor turns on and the selection screen for the USB connection is displayed.



- 4 Press   to select PRINT, then press .

- ONE MOMENT is displayed and the camera and printer are connected. The PRINT MODE SELECT screen is displayed on the monitor. Make the print settings on the camera's monitor.  Go to "Printing pictures" (P.171).

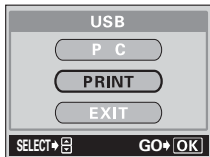

Note

- When the USB mode is set to PC, the PRINT MODE SELECT screen is not displayed. Remove the USB cable, and repeat the procedure from Step 1.

Printing pictures

When the camera is connected to a PictBridge-compatible printer, the PRINT MODE SELECT screen is displayed on the monitor. Use this screen to select the print mode. You can choose from the following print modes.

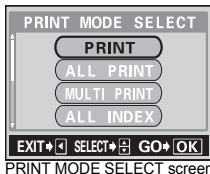

- PRINT** Prints the selected picture.
☞ "PRINT mode/MULTI PRINT mode" (P.174)
- ALL PRINT** Prints all the pictures stored on the card.
☞ "ALL PRINT mode" (P.178)
- MULTI PRINT** Prints one picture in multiple layout format.
☞ "PRINT mode/MULTI PRINT mode" (P.174)
- ALL INDEX** Prints an index of all the pictures stored on the card.
☞ "ALL INDEX mode/PRINT ORDER mode" (P.180)
- PRINT ORDER** Prints the pictures according to the print reservation data on the card. If no print reservations (P.158) have been made, this option is not available.
☞ "ALL INDEX mode/PRINT ORDER mode" (P.180)

Print modes and each setting

- Available printing modes, paper sizes etc., vary depending on the printer you use. Please consult with the services of your printer's manufacture or to the printer manual.

Easy printing

The method described below is the easiest way to print out pictures. The selected picture is printed without the date, time or file name.

- In the PRINT MODE SELECT screen (P.171), press to select PRINT, then press .**
 - The PRINT PAPER screen is displayed.

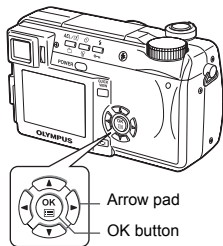

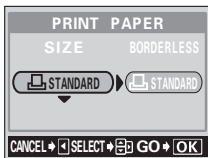

- Press to select the paper size, then press .**
 - When the PRINT PAPER screen is not displayed, SIZE, BORDERLESS and PICS/SHEET are set to STANDARD.
 - Go to Step 4.

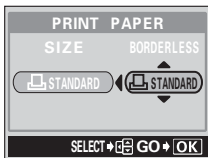

- Use to select framed or unframed, then press .**
 - OFF** The image is printed inside a blank frame.
 - ON** The image is printed filling the entire page.



4 Use   or the control dial to select the image you want to print and press .

- The PRINT screen is displayed.



5 Press   to select OK, then press .

- Printing starts.
- To cancel printing, select CANCEL and press . The PRINT MODE SELECT screen is displayed.
- When printing is finished, the screen returns to Step 4. Repeat Steps 4 and 5 and print all the pictures you want to print.

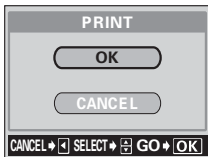

PRINT mode/MULTI PRINT mode

- 1** In the PRINT MODE SELECT screen, press to select PRINT or MULTI PRINT, then press .

- The PRINT PAPER screen is displayed.

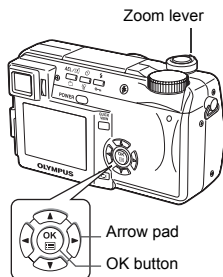

- 2** Press to select the paper size, then press .

- **PRINT** mode: Go to Step 3.
- **MULTI PRINT** mode: Go to Step 4.
- When the PRINT PAPER screen is not displayed, SIZE, BORDERLESS and PICS/SHEET are set to STANDARD. Go to step 5.

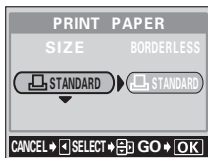

- 3** Use to select framed or unframed, then press . Go to step 5.

OFF () The image is printed inside a blank frame.

ON () The image is printed filling the entire page.

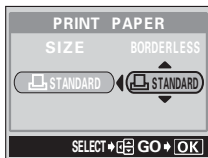

4 Press to select PICS/SHEET, then press .

- PICS/SHEET depends on the paper size set in Step 2 and the capabilities of your printer.

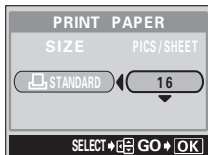

5 Press to select the picture you want to print.

- Turn the zoom lever toward W to display the pictures in index format. You can also select the pictures you want to print from the index.





6 Select the print reservation method.

SINGLE PRINT Makes a single-frame print reservation for the selected picture according to standard settings.

MORE Sets the number of prints of the selected picture in the print reservation data. You can also add the date or file name, and trim the picture.

●Set a SINGLE PRINT reservation







Press .

- Press  when the picture with  is displayed to cancel the reservation.

Print reservation mark is displayed.



● Set MORE print reservations

- ① Press .
 - Print information setting screen is displayed.
- ② Press   to select the item you want to set, then press .
 - Press   to select the item, then press .

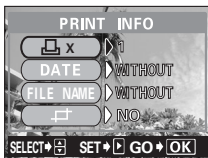

Sets the number of prints. You can select up to 10 prints.



If you select WITH, pictures are printed with the date and time.





If you select WITH, pictures are printed with the file name.



Crops part of a recorded picture so that only the enlarged section is printed.  "Trim the picture" (P.182)

- DATE and FILE NAME are not available in MULTI PRINT mode.

- ③ **When you have finished all the settings for MORE, press .**

- The screen displayed in Step 5 appears.
- To print more than one picture in PRINT and/or MULTI PRINT mode, repeat Steps 5 and 6 and make single and/or multiple print reservations for all the pictures you want to print.
-  is displayed in MULTI PRINT mode.

The settings you have made are displayed.

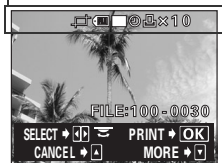

- 7 Press .

- The PRINT screen is displayed.

8 Print the pictures.

- Press to select OK or CANCEL, then press .

OK Printing starts.
CANCEL The settings are canceled and the monitor returns to the PRINT MODE SELECT screen.

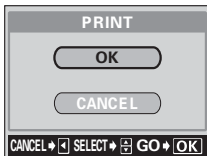

- When printing is finished, the monitor returns to the PRINT MODE SELECT screen.

"Exiting direct printing" (P.184)

● To cancel printing

Pressing during print data transfer displays the screen for selecting whether to continue or cancel printing. To cancel printing, press to select CANCEL, then press .

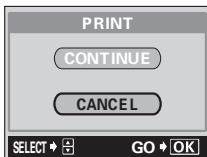

ALL PRINT mode

- 1** In the PRINT MODE SELECT screen, press to select ALL PRINT, then press .

- The PRINT PAPER screen is displayed.

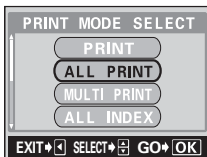

- 2** Press to select the paper size, then press .

- When the PRINT PAPER screen is not displayed, SIZE and BORDERLESS are set to STANDARD. Go to Step 4.

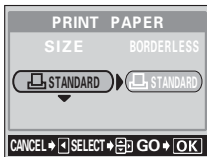

- 3** Use to select framed or unframed, then press .

OFF () The image is printed inside a blank frame.

ON () The image is printed filling the entire page.

- Print information settings screen is displayed.



- 4** Press to select the item you want to set, then press .

- Press to select the item, then press .

- If PRINT INFO cannot be set with your printer, go to Step 6.

- Only one print of each image can be made at a time.

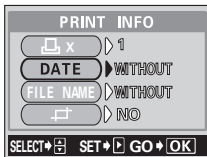

DATE ()

If you select WITH, pictures are printed with the date and time.



FILE NAME ()

If you select WITH, pictures are printed with the file name.

5 Press .

- The PRINT screen is displayed.

6 Print the pictures.

- Press   to select OK or CANCEL, then press .

OK Printing starts.





CANCEL The settings are canceled and the monitor returns to the PRINT MODE SELECT screen.



- When printing is finished, the monitor returns to the PRINT MODE SELECT screen.

 "Exiting direct printing" (P.184)

● To cancel printing

Pressing  during print data transfer displays the screen for selecting whether to continue or cancel printing. To cancel printing, press   to select CANCEL, then press .

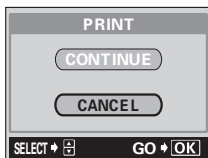

ALL INDEX mode/PRINT ORDER mode

- 1** In the PRINT MODE SELECT screen, press to select ALL INDEX or PRINT ORDER, then press .

- The PRINT PAPER screen is displayed.

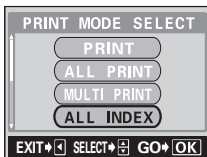

- 2** Press to select the paper size, then press .

- When the PRINT PAPER screen is not displayed, SIZE and BORDERLESS are set to STANDARD. Go to Step 4.



- 3** Use to select framed or unframed, then press .

OFF () The image is printed inside a blank frame.

ON () The image is printed filling the entire page.

- The print screen is displayed.
- BORDERLESS is not available in ALL INDEX mode. Press and go to Step 4.

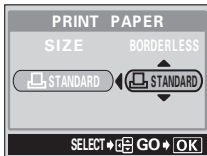

- 4** Print the pictures.

- Press to select OK or CANCEL, then press .

OK Printing starts.





CANCEL The settings are canceled and the monitor returns to the PRINT MODE SELECT screen.



- When printing is finished, the monitor returns to the PRINT MODE SELECT screen.

"Exiting direct printing" (P.184)

●To cancel printing

Pressing  during print data transfer displays the screen for selecting whether to continue or cancel printing. To cancel printing, press   to select CANCEL, then press .

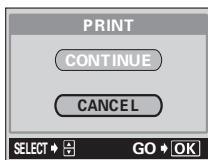

Trim the picture

To set the trim by MORE in PRINT or MULTI PRINT mode, follow the procedure below.

1 Use the arrow pad and zoom lever to select the trimming position and size.

- Press to move the trimming frame.
- Use the zoom lever to decide the trimming size. The trimming frame changes from horizontal to vertical and vice versa when the maximum or minimum size is reached.
- If trimming has already been set, the screen appears. Press to select RESET, then press .

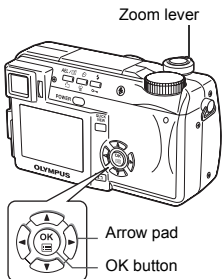

2 Press .



3 Press to select OK, then press .

- OK** Saves the current trimming size.
- RESET** Sets a new trimming size.
→ Repeat the procedure from Step 1.
- CANCEL** Cancels the current trimming setting.



- Press to complete trimming setting and return to the PRINT INFO screen.



Note

- The size of the printed picture varies depending on the printer settings. If the trimmed picture size is small, printing magnification increases accordingly, resulting in a printed picture with lower resolution.
- For the best results in enlarged prints, you are recommended to use the TIFF, SHQ or HQ mode.

Exiting direct printing

When you have finished printing, disconnect the camera from the printer.

- 1 In the **PRINT MODE SELECT** screen, select .

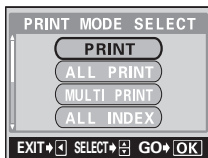

- The message is displayed.

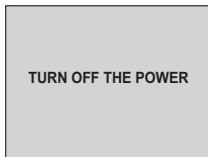

- 2 Press the power switch to turn the camera off.



Power switch

- 3 Remove the USB cable from the camera.

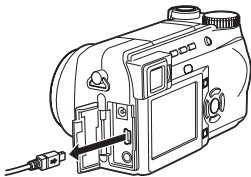



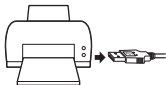

- 4 Remove the USB cable from the printer.



If an error code is displayed

If an error code appears on the camera's monitor during direct print setting or printing, see the following table.

For more details, refer to the printer's instruction manual.

Monitor indication	Possible cause	Corrective action
 NO CONNECTION	The camera is not connected to the printer correctly.	Disconnect the camera and connect it again correctly.
 NO PAPER	There is no paper in the printer.	Load some paper in the printer.
 NO INK	The printer has run out of ink.	Replace the ink cartridge in the printer.
 JAMMED	The paper is jammed.	Remove the jammed paper.
SETTINGS CHANGED	The printer's paper cassette has been removed or the printer has been manipulated while making settings on the camera.	Do not manipulate the printer while making settings on the camera.
 PRINT ERROR	There is a problem with the printer and/or camera.	Turn off camera and printer. Check the printer and remedy any problems before turning the power on again.











TIPS

- If an error code other than those shown above is displayed, refer to "Error codes" (P.186).

11 Miscellaneous

Error codes



Monitor indication	Possible cause	Corrective action
 NO CARD	The card is not inserted, or it cannot be recognized.	Insert a card or insert a different card. If the problem persists, format the card. If the card cannot be formatted, it cannot be used.
 CARD ERROR	There is a problem with the card.	Use a different card. Insert a new card.
 WRITE-PROTECT	Writing to the card is prohibited.	The recorded image has been protected (read-only) on a PC. Download the image to a PC and cancel the read-only setting.
 CARD FULL	The card is full. No more pictures, movies or information such as print reservations can be recorded.	Replace the card or erase unwanted pictures. Before erasing, download important images to a PC.
 NO PICTURE	There are no pictures on the card.	The card contains no pictures. Record pictures.
 PICTURE ERROR	There is a problem with the selected picture and it cannot be played back on this camera.	Use image processing software to view the picture on a PC. If that cannot be done, the image file is damaged.
 CARD-COVER OPEN	The card cover is open.	Close the card cover.
	The card is not formatted.	Format the card. All data on the card is deleted.



Troubleshooting

● Preparatory operations

Possible cause	Corrective action	Ref. page
The camera does not turn on or function buttons do not respond.		
The power is off.	Press the power switch to turn the camera on.	P.24
The battery is exhausted.	Charge the battery.	P.18
The battery is temporarily unable to function because of the cold.	Warm the battery by putting it in your pocket for a while.	—
The camera is in the sleep mode.	Operate the camera (press the shutter button or turn the zoom lever).	P.24
The camera is connected to a PC.	The camera will not operate while it is connected to a PC.	—

● Shooting

Possible cause	Corrective action	Ref. page
No picture is taken when the shutter button is pressed.		
The battery is exhausted.	Charge the battery.	P.18
The camera is in the playback mode.	Set the mode dial to any position except  .	P.47
The flash has not finished charging.	Remove your finger from the shutter button, and wait until the  (flash standby) indication stops blinking. Press the shutter button again.	P.57
The card is full.	Erase unwanted pictures or insert a new card. Before erasing, download important images to a PC.	P.133
The battery ran out of power during shooting or while the images were being written to the card. (Monitor turns off, or the battery check indicator blinks.)	Charge the battery. (Wait until the card access lamp turns off when flashing.)	P.18
The memory gauge is full.	Wait until there is room in the memory gauge.	P.15
There is a problem with the card.	Refer to "Error codes".	P.186
The viewfinder does not turn on.		
The monitor is turned on.	Press  to turn the viewfinder on.	P.47

Possible cause	Corrective action	Ref. page
The monitor does not turn on.		
The viewfinder is turned on.	Press  to turn the monitor on.	P.47
The viewfinder or monitor is hard to see.		
The diopter is not adjusted properly.	Adjust the diopter so that the AF target mark is clearly visible.	P.30
There is condensation* inside the camera.	Wait until the camera dries before turning it on again.	—
The brightness of the viewfinder or monitor is not adjusted properly.	Select  in the mode menu tab and adjust the brightness.	P.149
The monitor is exposed to direct sunlight.	Position the monitor in the down position or block the sunlight with your hand.	—
Vertical lines appear in the viewfinder or on the monitor screen during shooting.	Aiming the camera at a bright subject in sunlight may cause vertical lines to appear on the screen. This is not a malfunction.	—
The date recorded with the image data is wrong.		
The date/time is not set.	Set the date/time. The clock adjustment is not factory-preset.	P.28
The camera has been left with the battery removed.	If the camera is left for one day with the battery removed, the date/time setting is canceled. Set the date/time again.	P.20, 28
The settings are returned to the factory default settings when the camera is turned off.		
ALL RESET is set to ON.	Select the SETUP tab in the mode menu and set ALL RESET to OFF.	P.135
The picture is out of focus.		
The subject was too close.	Move further away from the subject. To take pictures closer than 7 cm (2.8") with the zoom in the maximum WIDE position, use the super macro mode.	P.82, 83
Auto focus is not possible.	Use manual focus or focus lock to focus on the subject and then shoot.	P.50, 68
There is condensation* on the lens.	Turn the camera off and wait until it dries before turning it on again.	—





* Condensation: When it is cold outside, the water vapor in the air is rapidly cooled and turns to droplets of water. Condensation occurs when the camera is suddenly taken from a cold place into a warm room.

Possible cause	Corrective action	Ref. page
The monitor goes off.		
The camera is in the sleep mode.	Operate the camera (press the shutter button or turn the zoom lever).	P.24
The power is turned off with the monitor off.	If ALL RESET in the mode menu is set to OFF, the camera settings before the power was turned off remain unchanged. Turn on the monitor, and turn off the power.	P.47, 135
The flash does not fire.		
The flash is closed.	Press the flash button to make the flash pop up.	P.57
The subject is illuminated.	If you want the flash to fire on a brightly illuminated subject, set the flash to fill-in mode.	P.57
Auto bracketing is set.	The flash does not fire in the auto bracketing mode. Set another mode in the DRIVE menu.	P.86
The camera is in the movie mode.	The flash does not fire in the movie mode. Set a different shooting mode.	P.52
FUNCTION is set to BLACK/WHITE BOARD.	The flash does not fire in the BLACK/WHITE BOARD mode.	P.93
Super macro mode is set.	The flash does not fire in the super macro mode. Cancel the super macro mode.	P.83
Panorama mode is set.	The flash does not fire in the panorama mode. Cancel the panorama mode.	P.89
The battery run time is brief.		
You are using the camera in a cold environment.	Battery performance deteriorates in low temperatures. Keep the camera warm by putting it inside your coat or clothing.	—
The remaining battery power is not indicated correctly.	When battery consumption fluctuates considerably, the camera may turn off without displaying the battery warning indicator. Charge the battery.	P.15, 18

●Playback of recorded images

Possible cause	Corrective action	Ref. page
The picture is out of focus.		
A subject unsuited to AF was taken.	Use manual focus or focus lock to focus on the subject and then shoot.	P.50, 68
The camera moved when the shutter button was pressed.	Hold the camera correctly and press the shutter button gently.	P.31
The flash was closed in a lighting condition requiring use of the flash.	Press the flash button to make the flash pop up. Camera movement occurs easily with slower shutter speeds. Use a tripod, or set the flash to AUTO.	P.57
The lens was dirty.	Clean the lens. Use a commercially available blower brush and then wipe with a lens cleaner to remove dust. Mold may form on the lens surface if the lens is left dirty.	P.206
The picture is too bright.		
The flash was set to the fill-in flash mode.	Select a flash mode other than fill-in flash.	P.57
The center of the subject is too dark.	If the center of the subject is too dark, the surrounding area emerges as too bright. Adjust the exposure compensation toward minus (-).	P.102
The ISO is at a high setting.	Set the ISO to AUTO or to a low sensitivity: 64	P.101
The aperture value is small in A (M) mode.	Increase the aperture value or set the camera to P mode.	P.66
The shutter speed setting is too slow in S (M) mode.	Increase the shutter speed or set the camera to P mode.	P.67

Possible cause	Corrective action	Ref. page
The picture is too dark.		
The flash was blocked by your finger.	Hold the camera correctly, keeping your fingers away from the flash.	P.31
The subject was out of the working range of the flash.	Shoot within the flash working range.	P.57
The flash was closed.	Press the flash button to make the flash pop up.	P.57
The subject was too small and was backlit.	Set the flash to fill-in mode, or use the spot metering mode.	P.57, 77
The sequential shooting mode was used.	Higher shutter speeds are used when the sequential shooting mode is selected, which may result in pictures that are darker than usual. Set <input type="checkbox"/> in the sequential shooting menu.	P.85
The center of the subject is too bright.	If the center of the subject is too bright, the image as a whole emerges darker. Adjust the exposure compensation toward plus (+).	P.102
The aperture value setting is too high in A (M) mode.	Decrease the aperture value or set the camera to P mode.	P.66
The shutter speed setting is too fast in S (M) mode.	Reduce the shutter speed or set the camera to P mode.	P.67
The colors of pictures look unnatural.		
Indoor lighting affected the picture's colors.	Set the white balance according to the lighting.	P.103
No white in the picture.	Include something white in the picture, or shoot using the fill-in flash mode.	P.57
The white balance setting is wrong.	Adjust the white balance according to the light source.	P.103
Part of the picture is too dark.		
The lens was partly blocked by your finger or the strap.	Hold the camera correctly, keeping your fingers and the strap away from the lens.	P.31







Possible cause	Corrective action	Ref. page
Halation produces unnatural colors in the picture.		
This may be caused by excessively bright ultraviolet light on the subject, such as sunlight shining through the leaves of trees, window frames in bright light at night, reflection of metal in direct sunlight, etc.	<ul style="list-style-type: none"> Use a UV filter. As this may upset the overall color balance, it should only be used in the conditions described on the left. Process the picture using a graphics application (Photoshop, Paint Shop Pro, etc.). For example, after picking up unnatural colors with a syringe tool, etc. you can select color areas, and try color conversion or saturation adjustment. For details, refer to the manual for the graphics application you are using. 	—
Pictures you have taken do not appear on the monitor.		
The power is off.	Set the mode dial to  before pressing the power switch to turn the camera on.	P.113
The camera is in the shooting mode.	Press the QUICK VIEW button or set the mode dial to  .	P.113, 114
There are no pictures on the card.	NO PICTURE appears on the monitor. Record pictures.	—
There is a problem with the card.	Refer to "Error codes".	P.186
The camera is connected to a TV.	The monitor does not function when the AV cable is connected to the camera.	P.125
Single-frame erase and all-frame erase cannot be performed.		
The pictures are protected.	Display pictures with  and press  to cancel protection.	P.131
No picture is displayed on the TV when connected to the camera.		
The video output signal is incorrect.	Set the video output signal according to the region where used.	P.157
The TV video signal setting is incorrect.	Set the TV to the video input mode.	P.125
The viewfinder or monitor is hard to see.		
The brightness of the viewfinder or monitor is not adjusted properly.	Select  in the mode menu and adjust the brightness.	P.149
The monitor is exposed to direct sunlight.	Position the monitor in the down position or block the sunlight with your hand.	—

● When the camera is connected to a PC or printer.

Possible cause	Corrective action	Ref. page
The printer fails to connect.		
PC was selected on the monitor after connecting to the printer with a USB cable.	Remove the USB cable, and start again from step 1 of "Connecting the camera to a printer".	P.170
The printer does not support PictBridge.	Refer to the printer's instruction manual or contact the manufacturer.	—
The camera is not recognized by the PC.		
The USB driver has not been installed.	It is necessary to install the USB driver for Windows 98/98SE. For installation instructions, see "DIGITAL CAMERA-PC CONNECTION OPERATION MANUAL" on the CD-ROM.	—
The camera has not been turned on.	Press the power switch to turn the camera on.	P.24

List of menus

● **AUTO** mode





Top menu	Setting	Ref. Page
DRIVE	 ,  , HI  , AF 	P.85
	SHQ 2288 × 1712, HQ 2288 × 1712, SQ1 1280 × 960, SQ2 640 × 480	P.96
		P.28
CARD SETUP	YES, NO	P.146

A/S/M/Pmode

Top menu	Tab	Function	Setting	Ref. Page
MODE MENU	CAMERA	ESP/	ESP, , MULTI	P.77
			OFF, ,	P.82
		DRIVE* ¹	, , AF , BKT* ⁵	P.85
		ISO	AUTO, 64, 100, 200, 400	P.101
		A/S/M* ²	A/S/M	P.65
		1/2/3/4* ³	MY MODE 1 – MY MODE 4	P.69
			-2.0 – +2.0	P.64
		SLOW	SLOW1, SLOW, SLOW2	P.63
		NOISE REDUCTION* ⁴	OFF, ON	P.110
		DIGITAL ZOOM* ⁶	OFF, ON	P.56
		FULLTIME AF	OFF, ON	P.71
		AF MODE	iESP, SPOT	P.70
		* ⁵		P.88
		PANORAMA* ⁶		P.89
		2 IN 1		P.91
		FUNCTION	OFF, BLACK & WHITE, SEPIA, WHITE BOARD, BLACK BOARD	P.93
		AF AREA		P.72
		INFO	OFF, ON	P.148
		* ⁷	OFF, ON	P.111
		(still pictures)	OFF, ON	P.94
	SUPER ZOOM	OFF, ON	P.55	
	PICTURE		TIFF, SHQ, HQ, SQ1, SQ2	P.96
		WB	AUTO, PRESET, 	P.103
			RED 7 – BLUE 7	P.106
		SHARPNESS	-5 – +5	P.107
		CONTRAST	-5 – +5	P.108
	CARD	SATURATION	-5 – +5	P.109
		CARD SETUP	YES, NO	P.146

To the next page

A/S/M/Pmode (cont.)

Top menu	Tab	Function	Setting	Ref. Page
MODE MENU	— SETUP	ALL RESET* ⁸	OFF, ON	P.135
			ENGLISH, FRANCAIS, DEUTSCH, ESPAÑOL, ITALIANO, РУССКИЙ, PORTUGUES	P.26
		PW ON/OFF SETUP	OFF, 1, 2	P.152
		REC VIEW	OFF, ON	P.150
		SLEEP	30 SEC, 1 MIN, 3 MIN, 5 MIN, 10 MIN	P.151
		MY MODE SETUP	CURRENT, RESET, CUSTOM	P.143
		FILE NAME	RESET, AUTO	P.154
		PIXEL MAPPING		P.155
				P.149
				P.28
		m/ft	m, ft	P.156
		VIDEO OUT	NTSC, PAL	P.157
		SHORT CUT	A, B, C	P.140
		CUSTOM BUTTON		P.137
			OFF, ON	P.152
(DRIVE)			Functions set as shortcuts	
(←⋮)				
(WB)				

*1 Not available in  mode.

*2 Only available in **A/S/M** modes.

*3 Only available in  mode.

*4 Not available in     modes.















*5 Not available in    **A/S/M** modes.

*6 Not available in **A/S/M** mode.













*7 Not available in **M** mode.

*8 Not available in  mode.







 mode

Top menu	Tab	Function	Setting	Ref. Page	
MODE MENU	CAMERA	ESP/ 	ESP,  , MULTI	P.77	
			OFF,  , 	P.82	
		ISO	AUTO, 64, 100, 200, 400	P.101	
		FULLTIME AF	OFF, ON	P.71	
			OFF, ON	P.83	
		FUNCTION	OFF, BLACK & WHITE, SEPIA	P.93	
			OFF, ON	P.95	
		PICTURE		-7 - +7	P.106
			SHARPNESS	-5 - +5	P.107
			CONTRAST	-5 - +5	P.108
	SATURATION		-5 - +5	P.109	
	CARD	CARD SETUP	YES, NO	P.146	
	SETUP	ALL RESET	OFF, ON	P.135	
			ENGLISH, FRANCAIS, DEUTSCH, ESPAÑOL, ITALIANO, РУССКИЙ, PORTUGUES	P.26	
		PW ON/OFF SETUP	OFF, 1, 2	P.152	
		FILE NAME	RESET, AUTO	P.154	
		PIXEL MAPPING		P.155	
				P.149	
				P.28	
		VIDEO OUT	NTSC, PAL	P.157	
			OFF, ON	P.152	
		DIGITAL ZOOM	OFF, ON	P.56	
		SHQ, HQ, SQ	P.96		
WB	AUTO, PRESET, 	P.103			

●  mode (still pictures)

Top menu	Tab	Function	Setting	Ref. Page	
MODE MENU	PLAY			P.158	
			OFF, ON	P.111	
			START	P.127	
	EDIT			640 × 480, 320 × 240, CANCEL	P.128
				NEW FILE, CANCEL	P.129
	CARD	CARD SETUP		ALL ERASE, FORMAT	P.134, 146
	SETUP	ALL RESET		OFF, ON	P.135
				ENGLISH, FRANCAIS, DEUTSCH, ESPAÑOL, ITALIANO, РУССКИЙ, PORTUGUES	P.26
		PW ON/OFF SETUP		OFF, 1, 2	P.152
		SCREEN SETUP			P.153
					P.149
					P.28
		VIDEO OUT		NTSC, PAL	P.157
				4, 9, 16	P.117
			OFF, ON	P.152	
				P.118	
INFO				P.148	
SWITCH FRAME		ALL, 		P.132	

















●  mode (movies)









Top menu	Tab	Function	Setting	Ref. Page	
MODE MENU	CARD	CARD SETUP	ALL ERASE, FORMAT	P.134, 146	
		SETUP	ALL RESET	OFF, ON	P.135
			ENGLISH, FRANCAIS, DEUTSCH, ESPAÑOL, ITALIANO, РУССКИЙ, PORTUGUES	P.26	
	PW ON/OFF SETUP		OFF, 1, 2	P.152	
				P.149	
				P.28	
	VIDEO OUT		NTSC, PAL	P.157	
			4, 9, 16	P.117	
			OFF, ON	P.152	
	MOVIE PLAY		MOVIE PLAYBACK	PLAYBACK, FRAME BY FRAME, EXIT	P.119
			INDEX	OK, RESET, CANCEL	P.121
EDIT			OK, RESET, CANCEL	P.123	
INFO				P.148	
SWITCH FRAME			ALL, 	P.132	

List of factory default settings







The functions are set as follows when the camera leaves the factory.

●Shooting mode





F No	F2.8
SHUTTER	1/1000
ZOOM	38mm
LCD	ON
	0.0
FLASH	AUTO (S, M:  SLOW1,  : )
AF/MF	AF
	OFF
	ESP
	OFF
DRIVE	
BKT	±1.0 EV, 3
ISO	AUTO (A, S, M: 64)
A/S/M	A
 1/2/3/4	MY MODE 1
	0.0
 SLOW	 SLOW1
NOISE REDUCTION	OFF ( : fixed on ON)
DIGITAL ZOOM	OFF
FULLTIME AF	OFF ( : ON)
AF MODE	iESP
	OFF
PANORAMA	OFF
2 IN 1	OFF
FUNCTION	OFF
AF AREA	CENTER
INFO	OFF
	OFF

 (still pictures)	OFF
 (movies)	OFF
SUPER ZOOM	OFF
	HQ (2288 × 1712,  : 320 × 240)
TIFF	2288 × 1712
SHQ	2288 × 1712
HQ	2288 × 1712
SQ1	1280 × 960 NORMAL
SQ2	640 × 480 NORMAL
WB	AUTO
	None
SHARPNESS	±0
CONTRAST	±0
SATURATION	±0
REC VIEW	ON
SLEEP	3 MIN
FILE NAME	RESET
m/ft	m
SHORT CUT	A: ESP/  , B:  C: 
CUSTOM BUTTON	AE LOCK

● Playback mode

SWITCH FRAME	ALL
INFO	OFF
	OFF
	OFF
	0°
	OFF
	9
	OFF



















● Others

ALL RESET	ON
	ENGLISH
PW ON/OFF SETUP	1
	NORMAL
	Y-M-D 2004.01.01 00:00
VIDEO OUT	NTSC or PAL*
	ON









* Settings differ according to the region where the camera is sold.

Modes and Shooting Functions

In **My** mode, available functions vary depending on the modes set in the MY MODE SETUP menu.

Mode Function		AUTO	   	A/S/M			P	
				A	S	M		
A/S/M		—	—	✓			—	—
Zoom		—	—	✓			—	—
DIGITAL ZOOM		—	—	✓			—	—
SUPER ZOOM		—	—	✓			—	—
AF MODE		—	—	✓			—	—
FULLTIME AF		—	—	✓			—	—
AF AREA		—	—	✓			—	—
Manual focus		—	—	✓			—	—
FLASH MODE	AUTO	—	✓	—	—	✓	—	—
		—	✓	—	—	✓	—	—
		—	✓	—	—	✓	—	—
	 SLOW1	—	—	✓			—	—
	  SLOW	—	✓	—	—	✓	—	—
	 SLOW2	—	—	✓			—	—
	 	—	—	✓			—	—
	—	—	✓			—	—	
 SLOW	—	—	✓			—	—	
	—	—	✓ ⁺¹			—	—	
AEL		—	—	✓			—	—
AF LOCK		—	—	✓			—	—
		—	—	✓			—	—
		—	—	✓			—	—

Mode Function		AUTO	A/S/M			P	
HI AF			✓*2				—
BKT		—	✓*2		—	✓	—
		—	✓*3		—	✓	—
PANORAMA		—	✓		—	✓	—
2 IN 1		—	✓				—
FUNCTION	BLACK&WHITE	—	✓				
	SEPIA	—	✓				
	WHITE BOARD	—	✓				—
	BLACK BOARD	—	✓				—
		—	✓				—
(movie)			—				✓
			✓				
ISO		—	✓				
		—	✓		—	✓	
WB		—	✓				
		—	✓				
SHARPNESS		—	✓				
CONTRAST		—	✓				
SATURATION		—	✓				
NOISE REDUCTION			—		✓		—
INFO		—	✓				—
		—	✓		—	✓	—
ALL RESET		—	✓*4				
		—	✓				
PW ON/OFF SETUP		—	✓				
REC VIEW		—	✓				—
SLEEP		—	✓				
MY MODE SETUP		—	✓				—

Function \ Mode	AUTO	   	A/S/M			P	
			A	S	M		
FILE NAME	—		✓				
PIXEL MAPPING	—		✓				
	—		✓				
			✓				
m/ft	—		✓				—
VIDEO OUT	—		✓				
SHORT CUT	—		✓				—
CUSTOM BUTTON	—		✓				—
	—		✓				

✓ : Available — : Not available

*1 Cannot be selected in **M**  mode.

*2 Cannot be selected in  mode.

*3 Can be selected only in  mode.

*4 Cannot be selected in  mode.

Camera maintenance

● After use

Turn off the camera and fit the lens cap on the lens.

If you do not intend to use the camera for a long period, remove the battery.

● Cleaning the camera

1 Turn off the camera. (👉 P.24)

2 Remove the battery. (👉 P.20) (If you are using an AC adapter, unplug the AC adapter from the camera first before removing the plug from the AC outlet.)

3 Exterior:

→ Wipe gently with a soft cloth. If the camera is very dirty, soak the cloth in mild soapy water and wring well. Wipe the camera with the damp cloth and then dry it with a dry cloth. If you have used the camera at the beach, use a cloth soaked in clean water and well wrung.

Viewfinder and monitor:

→ Wipe gently with a soft cloth.

Lens

→ Blow dust off the lens with a commercially available blower, then wipe gently with a lens cleaner.

Card

→ Wipe gently with a soft, dry cloth.

● Storage

- When storing the camera for extended periods, remove the battery and card, and keep in a cool, dry place that is ventilated well.
- Periodically, replace the battery, and test camera functions.



Note

- Do not use strong solvents such as benzene or alcohol, or chemically treated cloth.
- Cleaning should be done only after the battery has been removed or the AC adapter has been disconnected.
- Mold may form on the lens surface if the lens is left dirty.
- Avoid leaving the camera in places where chemical products are handled since this may result in corrosion.

Specifications

Product type	: Digital camera (for shooting and displaying)
Recording system	
Still picture	: Digital recording, TIFF (non-compression), JPEG (in accordance with Design rule for Camera File system (DCF))
Applicable standards	: Exif 2.2, Digital Print Order Format (DPOF), PRINT Image Matching II, PictBridge
Sound with still pictures	: Wave format
Movie	: QuickTime Motion JPEG support
Memory	: xD-Picture Card (16-512 MB)
Resolution	: 3200 × 2400 pixels (ENLARGE SIZE: SHQ, HQ) 2288 × 1712 pixels (TIFF, SHQ, HQ) 2288 × 1520 pixels (3:2 TIFF, SHQ, HQ) 2048 × 1536 pixels (TIFF, SQ1) 1600 × 1200 pixels (TIFF, SQ1) 1280 × 960 pixels (TIFF, SQ1) 1024 × 768 pixels (TIFF, SQ2) 640 × 480 pixels (TIFF, SQ2)
No. of storable pictures	
when using a 16 MB card (Without sound)	: Approx. 1 frame (TIFF : 2288 × 1712) Approx. 5 frames (SHQ : 2288 × 1712) Approx. 16 frames (HQ : 2288 × 1712) Approx. 49 frames (SQ1 : 1280 × 960 NORMAL) Approx. 165 frames (SQ2 : 640 × 480 NORMAL)
No. of effective pixels	: 4,000,000 pixels
Image pickup device	: 1/2.5" CCD solid-state image pickup, 4,110,000 pixels (gross)
Lens	: Olympus lens 6.3 mm to 63 mm, f2.8 to f3.7, 11 elements in 7 groups (equivalent to 38 mm to 380 mm lens on 35 mm camera)
Photometric system	: ESP metering, spot metering system
Aperture	: f2.8 to f8.0
Shutter speed	: 15 to 1/1000 sec.
Shooting range	: 0.6 m (2 ft.) to ∞ (W), 2 m (6.6 ft.) to ∞ (T) (NORMAL) 0.07 m (0.2 ft.) to ∞ (W), 1.2 m (4 ft.) to ∞ (T) (macro mode)
Viewfinder	: 0.44" TFT color LCD display, 240,000 pixels

Monitor	: 1.8" TFT color LCD display, 118,000 pixels
Auto focus	: TTL system autofocus Contrast detection system
Outer connector	: DC-IN jack, USB connector (mini-B), A/V OUT jack
Automatic calendar system	: 2000 up to 2099
Operating environment	
Temperature	: 0°C to 40°C (32°F to 104°F) (operation) -20°C to 60°C (-4°F to 140°F) (storage)
Humidity	: 30% to 90% (operation)/10% to 90% (storage)
Power supply	: Only an Olympus LI-10B lithium-ion battery AC adapter specified by Olympus (optional)
Dimensions	: 104.5 mm (W) × 60 mm (H) × 68.5 mm (D) (4.1" × 2.4" × 2.7") (excluding protrusions)
Weight	: 280 g (0.62 lb.) (without battery and card)

SPECIFICATIONS ARE SUBJECT TO CHANGE WITHOUT ANY NOTICE OR OBLIGATION ON THE PART OF THE MANUFACTURER.

Glossary of terms

A (Aperture Priority) Mode

You set the aperture yourself and the camera automatically varies the shutter speed so that the picture is taken with the best exposure.

AE (Automatic Exposure)

The camera's built-in exposure meter automatically sets the exposure. The 3 AE modes available on this camera are **P** mode, in which the camera selects both the aperture and shutter speed, **A** mode, in which the user selects the aperture and the camera sets the shutter speed, and **S** mode, in which the user selects the shutter speed and the camera sets the aperture. In **M** mode, the user selects both the aperture and the shutter speed.

Aperture

The adjustable lens opening which controls the amount of light that enters the camera. The larger the aperture, the shorter the depth of field and the fuzzier the background. The smaller the aperture, the greater the depth of field and the sharper the background. Larger aperture values indicate smaller apertures, and smaller aperture values indicate larger apertures.

CCD (Charge-Coupled Device)

This converts light passing through the lens into electrical signals. On this camera, light is picked up and converted into RGB signals to build a single image.

Contrast Detection Method

This is used to measure the distance to the subject. The camera determines if the image is focused by the level of contrast in the subject.

Conventional Photograph

This refers to recording images using silver halide (the method for recording images in conventional, non-digital photography). This system is in contrast to still video and digital photography.

DCF (Design rule for Camera File system)

A standard for image files by the Japan Electronics and Information Technology Industries Association (JEITA).

DPOF (Digital Print Order Format)

This is for saving desired print settings on digital cameras. By entering which images to print and the number of copies of each, the user can easily have the desired images printed by a printer or print lab that supports the DPOF format.

Eclipsing (Vignetting)

This refers to when an object obscures part of the field of view so that the whole subject is not photographed. Vignetting also refers to when the image seen through the viewfinder does not exactly match the image shot through the objective lens, so the photographed image includes objects not seen through the viewfinder. In addition, vignetting can occur when an incorrect lens hood is used, causing shadowing to appear in the corners of the image.

ESP (Electro-Selective Pattern) Light Metering/Digital ESP Light Metering

This determines the exposure by metering and calculating the light levels in the center and other areas of the image separately.

EV (Exposure Value)

A system for measuring exposure. EV0 is when the aperture is at F1 and the shutter speed is 1 second. The EV then increases by 1 each time the aperture increases by one F stop or the shutter speed increases by one increment. EV can also be used to indicate brightness and ISO settings.

Exposure

The amount of light used to capture an image. The exposure is determined by the time the shutter is open (shutter speed) and the amount of light that passes through the lens (aperture).

ISO

A method for indicating film speed by the International Organization for Standardization (ISO) (e.g. "ISO100"). Higher ISO values indicate greater sensitivity to light, so images can be exposed even in low-light conditions.

JPEG (Joint Photographic Experts Group)

A compression format for color still images. Photographs (images) shot using this camera are recorded onto the card in JPEG format when the Record mode is set to SHQ, HQ, SQ1 or SQ2. By downloading these images to a personal computer, users can edit them using graphics application software or view the images using an Internet web browser.

M (Manual) Mode

The user sets both the aperture and shutter speed.

NTSC (National Television Systems Committee) / PAL (Phase Alternating Line)

Television formats. NTSC is mainly used in Japan, North America and Korea. PAL is mainly used in Europe and China.

P (Program) Mode

Also called Program AE mode. The camera automatically sets the best shutter speed and aperture for the shot.

PictBridge

A standard for connecting digital cameras and printers of different makers and printing out pictures directly.

Pixels

A pixel is the smallest unit (dot) used to make up an image. Clear large-sized printed images require millions of pixels.

Resolution

The size of an image expressed by the number of pixels that make up the image. For instance, a picture taken in 640 × 480 resolution is the same size as the screen when the monitor setting is 640 × 480. However, if the monitor setting is 1024 × 768, the picture only takes up part of the screen.

S (Shutter Priority) Mode

Also called Shutter Priority AE mode. The user selects the shutter speed and the camera automatically varies the aperture so that the picture is taken with the best exposure.

Sleep Mode

A mode designed to save battery life. The camera automatically enters the sleep mode if you do not operate it for a certain time. To get out of the sleep mode, use any button on the camera (shutter button, arrow pad, etc.).

TIFF (Tagged Image File Format)

A format used for saving highly detailed black and white or color image data. TIFF image files can be handled by software programs for scanners and graphics applications. This camera uses an uncompressed image file format.











TFT (Thin-Film Transistor) Color Monitor



















A transistor color monitor constructed using thin-film technology.

TTL (Through the Taking Lens) System

To help adjust exposure, a light receptor built into the camera directly measures the light passing through the lens.

Index



- On** 131
1st curtain **SLOW1** 61
1st curtain with red-eye reduction
 SLOW1 62
2 IN 1 2 IN 1 91
2nd curtain **SLOW2** 62
3:2 97
- A**
- A/S/M** 65, 209, 210
A/V OUT jack 10, 125
AC adapter 23
AE 209
AE lock **AEL** 80
AE Lock/custom button **AEL**/ 11, 78, 80, 139
AE memory **MEMO** 81
AF 50, 76
AF AREA 72
AF LOCK 73
AF MEMORY 74
AF MODE 70
AF sequential
 shooting **AF**  85
AF target mark 47, 72
ALL ERASE 134
ALL RESET 135
All-frame erase  134
All-frame reservation 160
Aperture priority
 shooting **A** 45, 66
Aperture value 66
Arrow pad 11, 33, 113
Auto bracketing **BKT** 86
Auto white balance 103
Auto-flash 60
AV cable 125
- B**
- Battery 18
- Battery check 15
Battery compartment/card
 cover 11, 20
Beep sound  152
BKT 86
BLACK & WHITE 93
BLACK BOARD 93
- C**
- Camera movement warning 48
Card 19
Card access lamp 11, 47
Card check 25
CARD SETUP 146
CCD 209
Charger 18
Close-up playback  115
Cloudy day  104
Compression 96
Connector cover 10, 23, 125, 170
CONTRAST  108
Creating an index 121
CUSTOM BUTTON  137
- D**
- Date and time  28
DC-IN jack 10, 23
DCF 209
DIGITAL ZOOM 56
Diopter adjustment dial 11, 30
Direct printing 169
DPOF 158, 209
DRIVE 85
- E**
- Editing a movie 121
ENLARGE SIZE 97
Erase button 11, 133
Erasing pictures  133
Error codes 186

- ESP metering 77, 209
- EV 210
- Exposure 80
- Exposure compensation  102
- Exposure differential 68
- F**
- FILE NAME 154
- File No. 14
- Fill-in flash  60
- Flash 10, 57
- Flash button 11, 57
- Flash charge 59
- Flash intensity control  64
- Flash mode 57
- Flash mode button  11, 57
- Flash off  61
- Flash stand-by 48
- Fluorescent lamp  104
- Focus 48, 50
- Focus lock 50
- FORMAT  146
- FRAME BY FRAME 120
- Full-auto shooting **AUTO** 43
- FULLTIME AF 71
- Fully pressed 48
- FUNCTION 93
- G**
- Green lamp 48
- H**
- Halfway pressed 48
- HIGH 96
- High speed sequential
shooting **HI**  85
- Histogram display  111
- HQ. 98
- I**
- iESP 70
- Index display  116
- Information display **INFO** 148
- ISO sensitivity 101, 210
- J**
- JPEG 98, 210
- L**
- Landscape shooting  44
- Language  26
- Lens 10
- Lens cap 17
- Lens cap string 17
- Lithium ion battery 18
- M**
- Macro mode shooting  82
- Manual focus 75
- Manual shooting **M** 46, 68
- Measurement Unit **m/ft.** 156
- Memory gauge 15
- Metering  77
- Microphone 10, 94, 95, 127
- Mode 43
- Mode dial 10, 43
- MODE MENU 38
- Monitor 11, 12, 47, 113, 149
- Monitor brightness
adjustment  149
- Monitor button  11, 47
- Movies  46, 52, 119
- MOVIE PLAY 119
- MOVIE PLAYBACK 119
- Multi-metering 78
- MY MODE SETUP 143
- My Mode  46, 69
- MY MODE 69





N

- Night Scene shooting  44
- NOISE REDUCTION **NR** 110
- NORMAL (Record mode) 98
- Number of remaining pictures . . . 98
- NTSC 157, 210

O

- OK/Menu button  11, 32
- One-touch white balance  . . 104
- Optical zoom 54

P

- PAL 157, 210
- PANORAMA 89
- PictBridge 169, 210
- Picture rotation  126
- PIXEL MAPPING 155
- Playback mode 14, 37, 113
- Playback on TV 125
- Portrait shooting  43
- Power switch 11, 24
- Preset white balance 104
- Print setting  158
- Program shooting **P** 45
- Protect 131
- Protect button  11, 131
- PW ON/OFF SETUP 152





Q

- QUICK VIEW 114
- QUICK VIEW button 114











R



- REC VIEW 150
- Record mode  96
- Recording movies 46, 52
- Recording sound  94, 95, 127

Recording sound with still



- pictures  94
- Recording sound with movies  . . . 95
- Red-eye reduction flash  60
- Resizing  128
- Resolution 96, 210
- Rotation button  11, 126

S

- SATURATION **RGB** 109
- SCREEN SETUP 153
- Self-portrait shooting  88
- Self-timer  84
- Self-timer button  11, 84
- Self-timer lamp 10, 84
- SEPIA 93
- Sequential shooting  85
- SHARPNESS  107
- Shooting mode 12, 35, 38, 43
- SHORT CUT 140
- Shortcut Menus 35
- SHQ 98
- Shutter button 10, 47
- Shutter priority shooting **S** . . . 45, 67
- Shutter speed 67
- Single-frame erase  133
- Single-frame playback 113, 114
- Single-frame reservation 162
- Single-frame shooting 85
- SLEEP 151
- Sleep mode 151
- Slideshow  118
- Slow synchronization
 -  **SLOW** 61, 63
- Sports shooting  44
- Spot (AF mode) 70
- Spot metering  77
- SQ 98
- Standard 169
- Startup/Shutdown screen 25

Strap	17
Strap eyelet	10, 17
Sunny day 	104
Super macro mode	
shooting 	83
SUPER ZOOM	55
SWITCH FRAME	132

T

Taking still pictures	47
TIFF	98
Time remaining	52
Top menu	32
Trimming 	165, 182
Tripod socket	11
Tungsten light 	104

U

USB cable	170
USB connector	10, 170

V

VIDEO OUT	157
Viewfinder	11, 12, 30, 47, 149
Viewing still pictures 	113

W

White balance WB	103
White balance adjustment	
	106
WHITE BOARD	93

X

xD-Picture Card	19
-----------------	----

Z

Zoom lever	10, 54, 115, 116
------------	------------------

OLYMPUS®

<http://www.olympus.com/>

OLYMPUS CORPORATION

Shinjuku Monolith, 3-1 Nishi-Shinjuku 2-chome, Shinjuku-ku, Tokyo, Japan

OLYMPUS AMERICA INC.

Two Corporate Center Drive, Melville, NY 11747-3157, U.S.A. Tel. 631-844-5000

Technical Support (USA)

24/7 online automated help: <http://www.olympusamerica.com/support>

Phone customer support: Tel. 1-888-553-4448 (Toll-free)

Our phone customer support is available from 8 am to 10 pm

(Monday to Friday) ET

E-Mail: distec@olympus.com

Olympus software updates can be obtained at: <http://www.olympus.com/digital>

Olympus Europa GmbH

Premises/Goods delivery: Wendenstrasse 14-18, 20097 Hamburg, Germany

Tel: +49 40-23 77 3-0 / Fax: +49 40-23 07 61

Letters: Postfach 10 49 08, 20034 Hamburg, Germany

European Technical Customer Support:

Please visit our homepage <http://www.olympus-europa.com>

or call our TOLL FREE NUMBER* : **00800 - 67 10 83 00**

for Austria, Belgium, Denmark, Finland, France, Germany, Italy, Luxembourg,
Netherlands, Norway, Portugal, Spain, Sweden, Switzerland, United Kingdom

* Please note some (mobile) phone services/provider do not permit access or
request an additional prefix to +800 numbers.

For all not listed European Countries and in case that you can't get connected
to the above mentioned number please make use of the following

CHARGED NUMBERS: **+49 180 5 - 67 10 83** or **+49 40 - 237 73 899**

Our Technical Customer Support is available from 9 am to 6 pm MET (Monday to Friday)

CAMEDIA

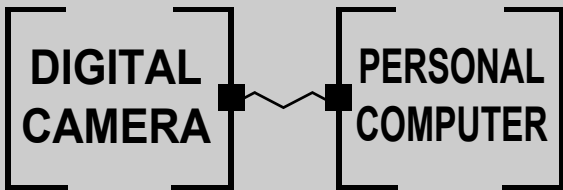

DIGITAL CAMERA — PC CONNECTION
OPERATION MANUAL

How to use your PC to get the most from images taken with your digital camera.

- Thank you for purchasing an Olympus digital camera.
- This manual provides instructions on how to install the USB driver. To ensure correct installation, refer only to these installation procedures.

Introduction

This manual explains in detail how to connect your Olympus digital camera to a computer. Read it carefully and keep it in a safe place for future reference.

About this manual

- The information contained in this manual may be subject to change without notice. For the latest information on the product, please consult your local Olympus representative.
- The information contained in this manual has been compiled by taking all possible measures to ensure its accuracy. However, if you find any errors or incomplete information, please contact your local Olympus representative.
- It is prohibited by copyright laws to duplicate in part or in whole the information contained in this manual, except for personal use. Reproduction without permission of the copyright owner is prohibited.
- The PC screens shown in this manual may differ slightly from the actual displays on some PC models.

Trademarks

- Microsoft and Windows are registered trademarks of Microsoft Corporation.
- Macintosh is a trademark of Apple Computer Inc.
- All other company and product names are registered trademarks and/or trademarks of their respective owners.

INDEX

Flowchart 4

Identifying the OS 6

Windows (98/Me/2000/XP) 8

Windows

Macintosh (OS 9/X). 23

Macintosh

**Downloading image files using other OS
(For other OS users). 31**

Flowchart

By connecting the camera to a computer with the provided USB cable, images on a card can be transferred to the computer. Some OS's (operating systems) may need a special setup before connecting to the camera for the first time. Follow the chart below.

For details, see the Olympus Corporate Site or phone customer support.

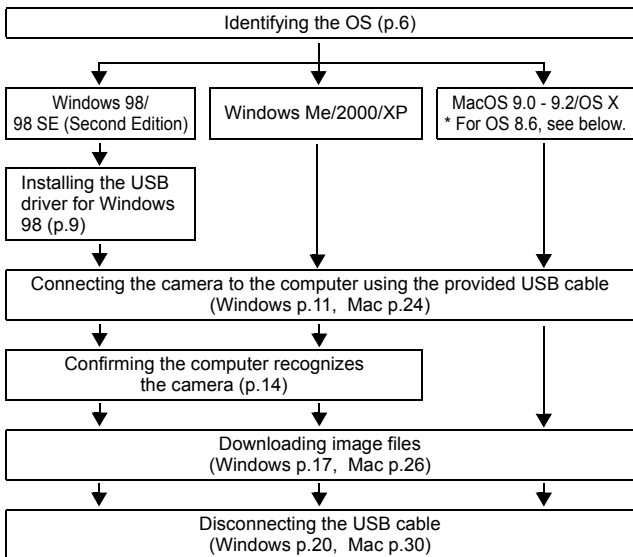

* Even if your computer has a USB connector, data transfer may not function correctly if you are using one of the operating systems listed below or if you have an add-on USB connector (extension card, etc.).

- Windows 95/NT 4.0
- Windows 98/98 SE upgrade from Windows 95
- Mac OS 8.6 or lower (except Mac OS 8.6 equipped with USB MASS Storage Support 1.3.5 installed at the factory)
- Data transfer is not guaranteed on a home-built PC system or PCs with no factory installed OS.



- When connecting the camera to the computer, make sure that there is sufficient remaining battery power. When connected (transmitting) to the computer, the camera does not enter the sleep mode nor will the camera's power turn off automatically. Depending on the camera model, when the battery power runs out or the internal temperature rises, the camera may stop operating automatically. This could cause the computer to malfunction, and any image data (file) being transmitted may be lost. Be careful when downloading files for a long period of time. Use the AC adapter (optional) when downloading files.
- If you connect or disconnect the AC adapter when the camera is connected to the computer and is running on battery power, it may result in the loss of image data on the card or cause a malfunction in the computer. Before connecting or disconnecting the AC adapter, disconnect the camera from the computer and make sure that the camera is turned off.
- To avoid computer malfunctions, do not turn off the camera when the camera is connected to a computer.
- If the camera is connected to the computer via a USB hub, operation may not be stable if there are any compatibility problems between the computer and the hub. In such cases, do not use the hub and connect the camera directly to the computer.



- You can view images using: graphics applications that support the JPEG file format (Paint Shop Pro, Photoshop, etc.); Internet browsers (Netscape Communicator, Microsoft Internet Explorer, etc.); CAMEDIA Master software; or other software. For details on using commercial graphics applications, refer to their instruction manuals.
- QuickTime is needed for playing back movies. QuickTime is included on the provided software CD.
- If you want to process images, make sure to download them to your computer first. Depending on the software, image files may be destroyed if the images are processed (rotated, etc.) while they are on the card.

Identifying the OS

Identify the OS on your computer before connecting the camera. How to identify the OS depends on the computer.

● Windows

1 Double-click the “My Computer” icon on your desktop.

When the “My computer” icon is not on your desktop, click “Control Panel” from the “Start” menu.

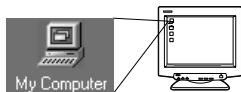

2 Double-click the “Control Panel” icon.



3 Double-click the “System” icon.



The way the file icons inside the folder appear may vary depending on your version of Windows. If you don't see the icon you are looking for, click on “view all Control Panel options” on the left of the window.

4 A System Properties window will appear. Note and record the “System:” information.

Confirm that your system is Windows 98, 98 SE, Me, 2000 Professional or Windows XP, then press “OK” to close the window.

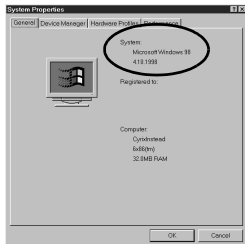

If your OS is Windows 98/98 SE, proceed to “Installing the USB driver for Windows 98” (👉 p.9).

Users running Windows Me/2000/XP 👉 p.11

Users running other OS 👉 p.31

● Mac OS (Macintosh)

Select “About This Computer” from the Apple menu on the menu bar.

A window appears with the name of the computer’s OS.

Confirm that the OS is OS 9.0-9.2 or OS X.

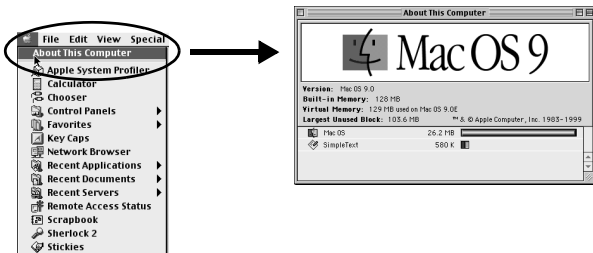

Users running Mac OS 9/X 👉 p.23

Users running other OS 👉 p.31

Windows

Using Windows 98/Me/2000/XP

Make sure that:

- Your computer is turned on and Windows is running.
- If you are running any applications, quit them all.
- You are recommended to power the camera using the optional AC adapter. If the battery power runs out while the computer is accessing the card in the camera, the camera will turn off in the middle of the operation and this could destroy image files (data). If you are using batteries, make sure that there is sufficient remaining battery power.

Installing the USB driver for Windows 98 (When using Windows 98/98 SE)	9
Connecting the camera to the computer	11
Confirming the computer recognizes the camera	14
Confirming the USB driver is installed	15
Downloading images to your computer.....	17
Disconnecting the camera from your computer	20

Installing the USB driver for Windows 98 (When using Windows 98/98 SE)

If your OS is Windows 98/98 SE, you must install the USB driver. Follow the instructions below to install the USB driver in your computer. Once it is fully installed, you do not need to repeat the procedure again.

If your OS is Windows Me/2000/XP, you do not need to install the USB driver. Proceed to “Connecting the camera to the computer” (👉 p.11).

- 1** Insert the provided software CD into your CD-ROM drive.

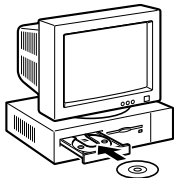

- 2** The Olympus Windows Installer should automatically launch. Click “USB Driver”.

If the USB driver is already installed in your computer, this option will not appear.

- This option will not appear if you are using Windows Me/2000/XP.



If the installer is not automatically launched, select “Run..” on the “Start” menu and then execute “(drive letter):/ Information.exe”.



The drive letter of the CD-ROM varies depending on the computer.
To identify the drive letter, double-click “My Computer” on the desktop.

- 3** Click “Continue”. The installation of the USB driver will start.



- 4** Click “OK” to restart your computer and the installation is complete.



- 5** When the computer has restarted, installation is complete. If the Olympus Windows Installer screen appears, click “Close” and remove the CD-ROM from the CD-ROM drive.

Connecting the camera to the computer

Users running Windows 98/98SE need to install the USB drive before connecting the camera to your computer for the first time. (🖱️ p.9)

- 1** Some camera models have a “USB” setting in the menu. Make sure that “PC” is selected before connecting. This is not required if your camera does not have this setting. For details on how to operate the menu, refer to your camera's reference manual.

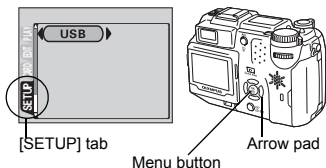

- 2** Insert the marked end of the provided USB cable into the USB port on your computer as shown below.

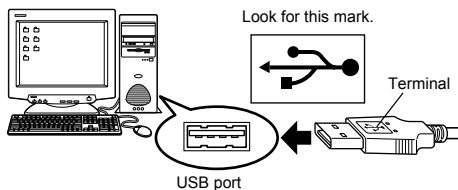



The location of the USB port varies depending on the computer. For details, refer to your computer's manual.

- 3** After making sure that the camera is turned off, connect the end of the USB cable to the USB connector on the camera.

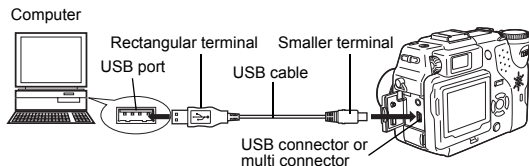
The location of the USB connector or multi connector varies depending on the camera model. Refer to the camera manual for details.



4 Turn the camera on in (playback) mode.

- Most cameras with a lens barrier turn on automatically in Step 3, with the exception of some models which require you to press the  (monitor) button or  button.

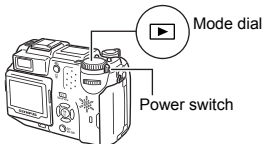
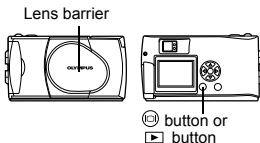

5 When the screen shown right appears on the monitor in Step 4, use the arrow pad to select "PC" and press the OK button.

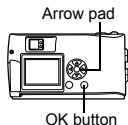
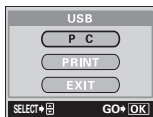

6 The computer recognizes the camera as a new device.

- Depending on the camera model, when you connect the camera to the computer, the lamp on the right of the viewfinder or the self-timer lamp may light.

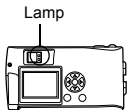

When you connect the camera to the computer for the first time, the computer automatically recognizes the camera. Click "OK" when the message saying that the installation is completed appears. The computer recognizes the camera as a "Removable Disk".

● **Windows XP**

You can download image files from the camera easily. Select "Copy pictures to folder on my computer using Microsoft Scanner and Camera Wizard", then follow the on-screen instructions. You may also select "take no action" to bypass the Microsoft Scanner and Camera Wizard. You may then use a more advanced image viewing/editing program such as Olympus CAMEDIA Master software. For detailed instructions on downloading, refer to the CAMEDIA Master software user's guide.



Caution

When the camera is connected to the computer, none of the camera buttons are functional.

Confirming the computer recognizes the camera

- 1 Double-click the “My Computer” icon on the desktop.**
For users running Windows XP, click “My Computer” from the “Start” menu.

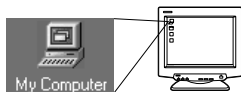

- 2 Make sure the “Removable Disk” icon appears in the window.**

There may already be other “Removable Disk” icons for other devices, such as a removable media drive or USB SmartMedia Reader/Writer. In this case, the digital camera is recognized as another “Removable Disk”.

If you cannot find the icon, the camera and computer are not connected properly. Turn the camera off, disconnect the camera from the computer and connect again, or proceed to “Confirming the USB driver is installed” (p.15) to make sure that the USB driver is fully installed.

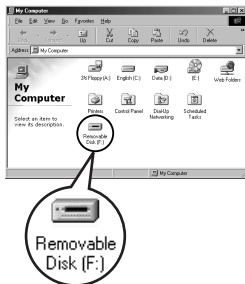

Confirming the USB driver is installed

If the computer does not recognize the camera as a Removable Disk, follow the procedure below to check whether the USB driver has been fully installed.

- 1** Open “My Computer” and double-click the “Control Panel” icon. For users running Windows XP, open “Control Panel” from the “Start” menu.



- 2** Double-click the “System” icon.

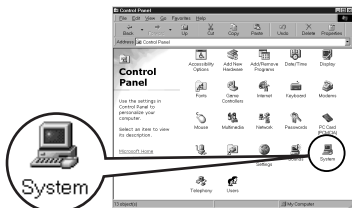

- 3** The System window will appear. Click the “Device Manager” tab.

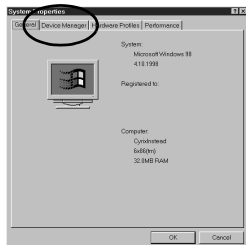

4 Confirm that “OLYMPUS Digital Camera” is in the “Universal Serial Bus Controller” category.

If you cannot find the “OLYMPUS Digital Camera”, turn the camera off, disconnect the camera from the computer and start again.

Users running Windows 98/98 SE start again from “Confirming the USB driver is installed”, and Users running Windows Me/2000/XP start from “Connecting the camera to the computer”.

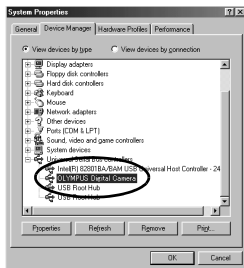

Note

If the USB driver was successfully installed, you can find the following in the “Device Manager”.

- the name of the camera you have connected listed under “Disk drives”
- “OLYMPUS Digital Camera” listed as one of the items in the “Universal Serial Bus Controller” category

Downloading images to your computer

1 Double-click the “My Computer” icon on the desktop.

For users running Windows XP, click “Control Panel” from the “Start” menu.

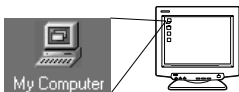

2 Double-click the “Removable Disk” icon.

A new “Removable Disk” icon appears when the camera is connected to the computer, as the digital camera is recognized as a “Removable Disk”.

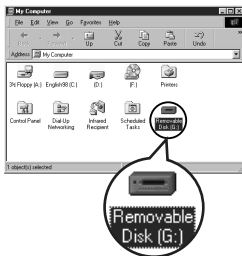

If an error message appears when you double-click the icon, there may be a problem with one of the following:

- ① the camera's power source (the AC adapter is not properly connected or the battery power is low)
Make sure that the AC adapter is correctly connected or that the batteries are not running low.
- ② the card (there is no card in the camera or there is a problem with the card)
Check that you can play back pictures stored on the card on the monitor of your digital camera.

3 Double-click the “Dcim” folder.

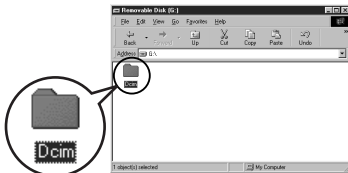

4 Double-click the “100olymp” folder.

Image files (JPEG files) with file names such as “P1010001.jpg” are displayed.

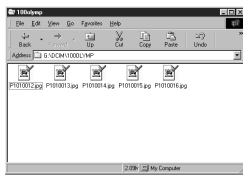

Note

- The camera automatically assigns folder names and file names according to the following rules.

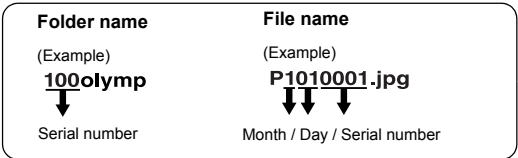

- Serial numbers of image files run from 0001 to 9999.
- Serial numbers of folders run from 100 to 999.
- When file number 9999 is reached, a new folder is created and assigned the next number.
- Months January through September are expressed by the numbers 1 through 9, October by the letter A, November by B and December by C.

5 Double-click the “My Documents” icon on the desktop.

If you cannot find the icon on the desktop, select “Explorer” on the Start menu and double-click the “My Documents” icon.

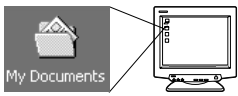

The “My Documents” window is displayed.



- 6** Drag & drop the image you want to save in the computer (in this case, P1010012.jpg) to the “My Documents” window.

The image is saved in the computer (in My Documents folder).

- To select all files, choose Edit > Select all.

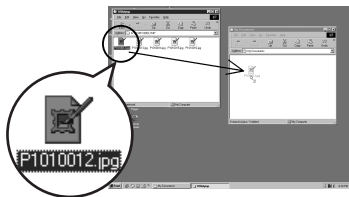

Note

When the image file has been downloaded to the computer, you can view images by double-clicking the image files downloaded to your computer. The files will be opened in the default image viewer of the operating system. If you want to view the image a different size or process it, you will need to open the image with software that supports JPEG or TIFF images files, such as Paint Shop Pro, Photoshop or CAMEDIA Master software.



Caution

The lamp on the right of the viewfinder or the card access lamp blinks while the image is being copied. Never open the card cover on the camera, load or remove the batteries, or connect or disconnect the AC adapter while the lamp is blinking as the image files may be destroyed.

Disconnecting the camera from your computer

If your OS is Windows Me/2000, proceed to “Windows Me/2000/XP” (p.21).

● Windows 98

- 1** Make sure that the lamp on the right of the viewfinder or the self-timer lamp (which on some models light while the camera is connected to the computer) or the card access lamp is not blinking. The lamps and their location vary depending on the model. Refer to your camera's reference manual.

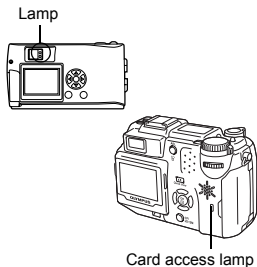

- 2** Double-click the “My Computer” icon and right-click the “Removable Disk” to display the menu.
- 3** Click “Eject” on the menu.



- 4** Make sure that the lamp on the right of the viewfinder or the self-timer lamp (which on some models light while the camera is connected to the computer) or the card access lamp is not blinking.

Depending on the camera model, the green lamp may light or lamps that were lit while the camera was connected to the computer may go off. If the lamp is not flashing, then the cable can be removed.

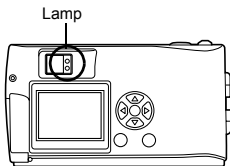

- 5** Remove the USB cable from the camera.

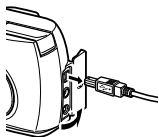

- 6** Remove the USB cable from your computer.

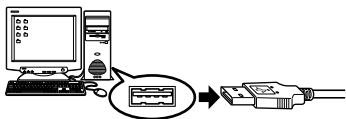

● Windows Me/2000/XP

- 1** Make sure that the lamp on the right of the viewfinder or the self-timer lamp (which on some models light while the camera is connected to the computer) or the card access lamp is not blinking.

The lamps and their location vary depending on the model. Refer to your camera's reference manual.

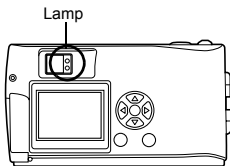

- 2** Click the  “Unplug or Eject Hardware” icon on the task bar.

The message saying that the drive has been stopped appears.

- 3** Click on the message.

The “Unplug or Eject Hardware” window appears.

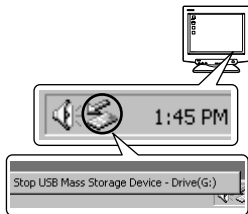

- 4** When a message appears, click “OK”.



- 5** Remove the USB cable from the camera.

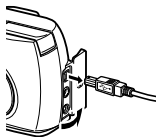

- 6** Remove the USB cable from your computer.

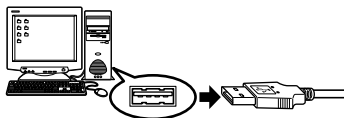

Caution

If the window returns the following message when you click “Unplug or Eject Hardware”, first make sure that no image data is being downloaded from the camera, and then remove the USB cable.



Macintosh

Using Mac OS (9/X)

Make sure that:

- Your computer is turned on and Mac OS is running.
- If you are running any applications, quit them all.
- You are recommended to power the camera using the optional AC adapter. If the battery power runs out while the computer is accessing the card in the camera, the camera will turn off in the middle of the operation and this could destroy image files (data). If you are using batteries, make sure that there is sufficient remaining battery power.

If you are running Mac OS X, the connection to the computer and downloading the image data are verified. Restrictions such as the following may occur due to the OS.

- The image file properties are not displayed correctly.
- Images in the camera cannot be opened without first downloading them. etc.

For more details, visit the Olympus web site.

Connecting the camera to the computer	24
Downloading images to your computer.....	26
Disconnecting the camera from your computer	30

Connecting the camera to the computer

- 1** Some camera models have a “USB” setting in the menu. Make sure that “PC” is selected before connecting. This is not required if your camera does not have this setting. For details on how to operate the menu, refer to your camera's reference manual.

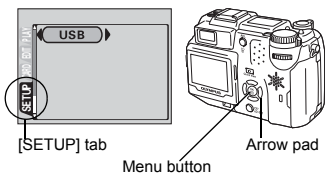

- 2** Insert the marked end of the USB cable into the USB port on your computer as shown below.

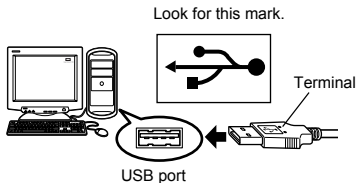

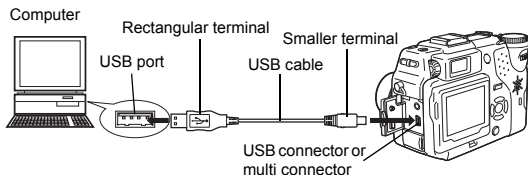

The location of the USB port varies depending on the computer. For details, refer to your computer's manual.

- 3** After making sure that the camera is turned off, connect the end of the USB cable to the USB connector on the camera. The location of the USB connector or multi connector varies depending on the camera model. Refer to the camera manual for details.



4 Turn the camera on in (playback) mode.

- Most cameras with a lens barrier turn on automatically in Step 3, with the exception of some models which require you to press the  (monitor) button or  button.

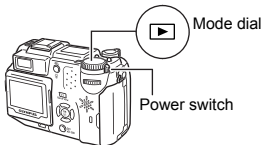
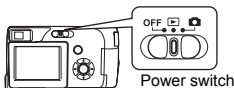
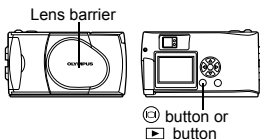

5 When the screen shown right appears on the monitor in Step 4, use the arrow pad to select “PC” and press the OK button.

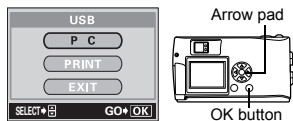

6 The computer recognizes the camera as a new device.

- Depending on the camera model, when you connect the camera to the computer, the lamp on the right of the viewfinder or the self-timer lamp may light.

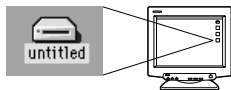

The computer recognizes the camera automatically and an “Untitled” icon appears on the desktop. If you cannot find this icon, turn off the camera and connect again.

● Mac OS X

When the computer has recognized the camera, the Apple Image Capture software automatically launches.  p.29



When the camera is connected to the computer, none of the camera buttons are functional.

Downloading images to your computer

● Mac OS 9

You can download images from the camera and save them in your computer (in this case, in the Hard Disk).

- 1** Double-click the “Untitled” icon displayed on the desktop when the camera is connected to the computer.



If you cannot find this icon, or if an error message appears when you double-click the icon, there may be a problem with one of the following:

- ① the camera's power source (the AC adapter is not properly connected or the battery power is low)
- ② the card (there is no card in the camera or there is a problem with the card)
Check that you can play back pictures on the monitor of your camera.
- ③ the USB cable (the camera is not properly connected to the computer by the USB cable).
- ④ Apple “File Exchange” extension is not enabled.
 - Please refer to your Apple operating system manual for instructions on how to enable this extension.

- 2** Double-click the “Dcim” folder.

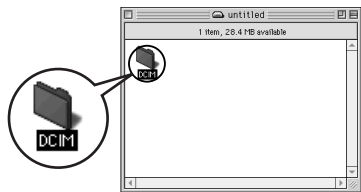

- 3** Double-click the “100OLYMP” folder.

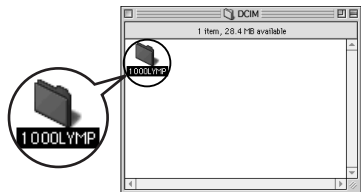
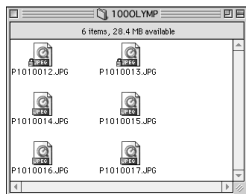
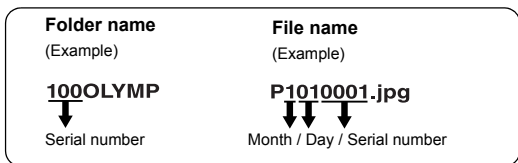

Image files (JPEG files) with file names such as “P1010001.JPG” are displayed.



- The camera automatically assigns folder names and file names according to the following rules.



- Serial numbers of image files run from 0001 to 9999.
- Serial numbers of folders run from 100 to 999.
- When file number 9999 is reached, a new folder is created and assigned the next number.
- Months January through September are expressed by the numbers 1 through 9, October by the letter A, November by B and December by C.

- 4** Double-click the “Macintosh HD” icon on the desktop.

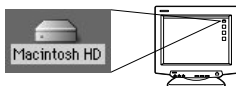

The “Hard Disk” window is displayed.

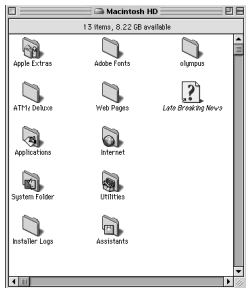

- 5 Drag & drop the image you want to save in the computer (in this case, P1010012.JPG) to the “Hard Disk” window.

The image is saved in the computer (in the Hard disk).

- To select all images, click Edit > Select all.

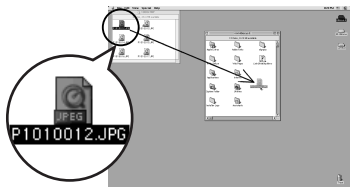

When the image file has been copied to the computer, you can view images by double-clicking the image files in the “Hard Disk” folder. The files will be opened in the default image viewer of the operating system. If you want to view the image a different size or process it, you will need to open the image with software that supports JPEG or TIFF images files, such as Paint Shop Pro, Photoshop or CAMEDIA Master software.



The lamp on the right of the viewfinder or the card access lamp blinks while the image is being copied. Never open the card cover on the camera, load or remove the batteries, or connect or disconnect the AC adapter while the lamp is blinking as the image files may be destroyed.

● Mac OS X

Malfunions such as the following may occur due to the OS.

- If the camera is not connected correctly, a malfunction occurs in the computer.
- Date and time information of image files is not accurately displayed.
- If the card cover of the camera is opened while connecting to the computer, the “untitled” icon does not disappear from the desktop, etc.

When the computer has recognized the camera, the Apple Image Capture software dialog appears.

1 From the “Download To” menu, select a destination folder.

2 To download all images, click “Download All”.

To selectively download images, click “Download Some” and highlight the desired images.



The images are transferred from the camera to your computer.



If you are operating Mac OS X and you want to download images using the same procedure as for Mac OS 9, select “File > Close” and exit the Apple Image Capture software. At this time, the camera is indicated as “unlabeled”.



If you use the Apple Image Capture software, images downloaded to your computer and transferred back to a card may not play back on the camera or may have other problems.

Disconnecting the camera from your computer

- 1** Make sure that the lamp on the right of the viewfinder or the self-timer lamp (which on some models light while the camera is connected to the computer) or the card access lamp is not blinking.

The lamps and their location vary depending on the model. Refer to your camera's reference manual.

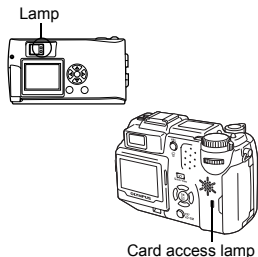

- 2** Drag the "untitled" icon on the desktop to "Trash".

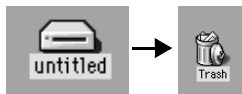

- 3** Make sure that the lamp on the right of the viewfinder or the self-timer lamp (which on some models light while the camera is connected to the computer) or the card access lamp is not blinking.

Depending on the camera model, the green lamp may light or lamps that were lit while the camera was connected to the computer may go off. If the lamp is not flashing, then the cable can be removed.

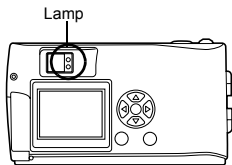

- 4** Remove the USB cable from the camera.

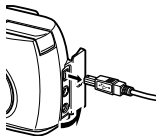

- 5** Remove the USB cable from your computer.

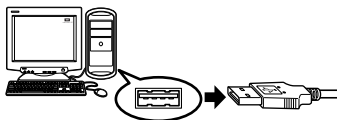

Downloading image files using other OS

(For other OS users)

Users running other OS cannot connect the camera directly to a computer.

- **Windows 95**
- **Windows NT**
- **Mac OS before OS 9**

For an OS listed above, you can download images directly to your computer using an optional floppy disk adapter or PC card adapter.

For details, see the Olympus Corporate Site or phone customer support.

Does your computer have a USB interface?

Is there a port marked  on your computer?

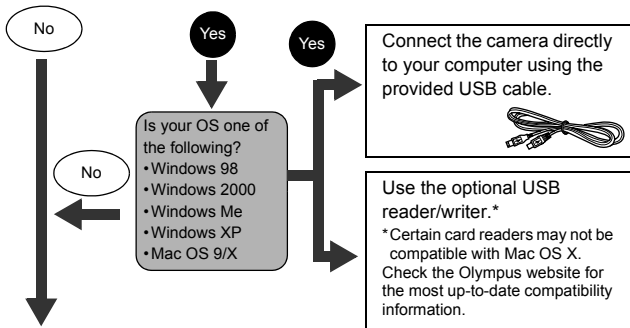

Does your computer have a built-in PC card slot?

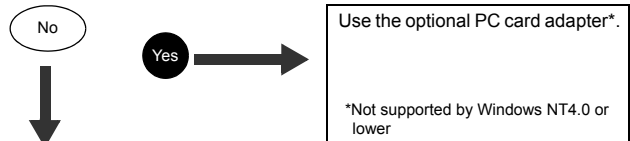

Consult your nearest Olympus representative.

OLYMPUS®

<http://www.olympus.com/>

OLYMPUS CORPORATION

Shinjuku Monolith, 3-1 Nishi-Shinjuku 2-chome, Shinjuku-ku, Tokyo, Japan

OLYMPUS AMERICA INC.

Two Corporate Center Drive, Melville, NY 11747-3157, U.S.A. Tel. 631-844-5000

Technical Support (USA)

24/7 online automated help: <http://www.olympusamerica.com/support>

Phone customer support: Tel. 1-888-553-4448 (Toll-free)

Our phone customer support is available from 8 am to 10 pm
(Monday to Friday) ET

E-Mail: distec@olympus.com

Olympus software updates can be obtained at: <http://www.olympus.com/digital>

Olympus Europa GmbH

Premises/Goods delivery: Wendenstrasse 14-18, 20097 Hamburg, Germany

Tel: +49 40-23 77 3-0 / Fax: +49 40-23 07 61

Letters: Postfach 10 49 08, 20034 Hamburg, Germany

European Technical Customer Support:

Please visit our homepage <http://www.olympus-europa.com>

or call our TOLL FREE NUMBER* : **00800 - 67 10 83 00**

for Austria, Belgium, Denmark, Finland, France, Germany, Italy, Luxembourg,
Netherlands, Norway, Portugal, Spain, Sweden, Switzerland, United Kingdom

* Please note some (mobile) phone services/provider do not permit access or
request an additional prefix to +800 numbers.

For all not listed European Countries and in case that you can't get connected
to the above mentioned number please make use of the following

CHARGED NUMBERS: **+49 180 5 - 67 10 83** or **+49 40 - 237 73 899**

Our Technical Customer Support is available from 9 am to 6 pm MET (Monday to Friday)