



SAMSUNG

# User Manual

## NV100HD

---

This user manual includes detailed usage instructions for your camera. Please read this manual thoroughly. Click a button below for more information.

Quick search

Contents

1 Basic functions

2 Extended functions

3 Shooting options

4 Playback/Editing

5 Appendix

Index



# Health and Safety Information

---

Always comply with the following precautions and usage tips to avoid dangerous situations and ensure peak performance of your camera:



**Warning**—situations that could cause injury to yourself or others



**Caution**—situations that could cause damage to your camera or other equipment



**Note**—notes, usage tips, or additional information



## Safety Warnings

### Do not use your camera near flammable or explosive gases and liquids

Do not use your camera near fuels, combustibles, or flammable chemicals. Do not store or carry flammable liquids, gases, or explosive materials in the same compartment as the camera or its accessories.

### Keep your camera away from small children and pets

Keep your camera and all accessories out of the reach of small children and animals. Small parts may cause choking or serious injury if swallowed. Moving parts and accessories may present physical dangers as well.

### Prevent damage to subjects' eyesight

Do not use the flash in close proximity (closer than 1 m/3 ft) to people or animals. Using the flash too close to your subject's eyes can cause temporary or permanent damage.

### Handle and dispose of batteries and chargers with care

- Use only Samsung-approved batteries and chargers. Incompatible batteries and chargers can cause serious injuries or damage to your camera.
- Never dispose of batteries in a fire. Follow all local regulations when disposing of used batteries.
- Never place batteries or cameras on or in heating devices, such as microwave ovens, stoves, or radiators. Batteries may explode when overheated.



### Safety Precautions

CAUTION

### Handle and store your camera carefully and sensibly

- Do not allow your camera to get wet—liquids can cause serious damage. Do not handle your camera with wet hands. Water damage to your camera can void your manufacturer's warranty.
- Do not expose the camera to direct sunlight or high temperatures for an extended period of time. Prolonged exposure to sunlight or extreme temperatures can cause permanent damage to your camera's internal components.
- Avoid using or storing your camera in dusty, dirty, humid, or poorly-ventilated areas to prevent damage to moving parts and internal components.

- Remove the batteries from your camera when storing it for an extended period of time. Installed batteries may leak or corrode over time and cause serious damage to your camera.
- Protect your camera from sand and dirt when using it on beaches or in other similar areas.
- Protect your camera and monitor from impact, rough handling, and excessive vibration to avoid serious damage.
- Exercise caution when connecting cables or adapters and installing batteries and memory cards. Forcing the connectors, improperly connecting cables, or improperly installing batteries and memory cards can damage ports, connectors, and accessories. Do not insert foreign objects into any of your camera's compartments, slots, or access points. Damage due to improper use may not be covered by your warranty.

### Protect batteries, chargers, and memory cards from damage

- Avoid exposing batteries or memory cards to very cold or very hot temperatures (below 0° C/32° F or above 40° C/104° F). Extreme temperatures can reduce the charging capacity of your batteries and can cause memory cards to malfunction.
- Prevent batteries from making contact with metal objects, as this can create a connection between the + and – terminals of your battery and lead to temporary or permanent battery damage.
- Prevent memory cards from making contact with liquids, dirt, or foreign substances. If dirty, wipe the memory card clean with a soft cloth before inserting in your camera.

- Turn off the camera when inserting or removing the memory card.
- Do not bend drop, or subject memory cards to heavy impact or pressure.
- Do not use memory cards that have been formatted by other cameras or by a computer. Reformat the memory card with your camera.
- Never use a damaged charger, battery, or memory card.

### Use only Samsung-approved accessories

Using incompatible accessories may damage your camera, cause injury, or void your warranty.

### Protect your camera's lens

- Do not expose the lens to direct sunlight, as this may discolour the image sensor or cause it to malfunction.
- Protect your lens from fingerprints and scratches. Clean your lens with a soft, clean, debris-free lens cloth.



### Important Usage Information

#### Allow only qualified personnel to service your camera

Do not allow unqualified personnel to service the camera or attempt to service the camera yourself. Any damage that results from unqualified service is not covered by your warranty.

#### Ensure maximum battery and charger life

- Overcharging batteries may shorten battery life. After charging is finished, disconnect the cable from your camera.
- Over time, unused batteries will discharge and must be recharged before use.
- Disconnect chargers from power sources when not in use.
- Use batteries only for their intended purpose.

#### Exercise caution when using the camera in humid environments

When transferring the camera from a cold environment to a warm and humid one, condensation can form on the delicate electronic circuitry and memory card. In this situation, wait for at least 1 hour until all moisture has evaporated before using the camera.

#### Check that the camera is operating properly before use

The manufacturer takes no responsibility for any loss of files or damage that may result from camera malfunction or improper use.

©2008 SAMSUNG DIGITAL IMAGING CO., LTD.

The specifications of the camera or contents of this manual may be changed without prior notice due to upgrade of camera functions.

### Copyright information

- Microsoft Windows and the Windows logo are registered trademarks of the Microsoft Corporation.
- HDMI, the HDMI logo and the term "High Definition Multimedia Interface" are trademarks or registered trademarks of HDMI Licensing LLC.
- QuickTime® and QuickTime® logo are trademarks or registered trademarks of Apple Computer, Inc., used under license.

## Organisation of the user manual

<b>1</b>	<b>Basic functions</b> .....	10
	Learn about your camera's layout, icons, and basic functions for shooting.	
<b>2</b>	<b>Extended functions</b> .....	19
	Learn how to take a photo by selecting a mode and how to record a video or voice memo.	
<b>3</b>	<b>Shooting options</b> .....	29
	Learn about the options you can set in shooting mode.	
<b>4</b>	<b>Playback/Editing</b> .....	47
	Learn how to play back photos, videos, or voice memos and edit photos or videos. You will also learn how to connect your camera to your computer, photo printer, TV, or HDTV.	
<b>5</b>	<b>Appendix</b> .....	67
	Refer to settings, error messages, specifications, and maintenance tips.	

## Indications used in this manual

Shooting mode	Indication
AUTO	<b>AUTO</b>
PROGRAM	<b>P</b>
MANUAL	<b>M</b>
DUAL IS	DUAL
NIGHT	
BEAUTY SHOT	
SCENE	<b>SCENE</b>
MOVIE	

### Shooting mode icons next to a title

These icons indicate that a function is available in the corresponding modes. The **SCENE** mode may not support functions for all scenes.

e.g.)

**Preventing red-eye** SCENE

If the flash fires when you take a photo of a person in the dark, a red glow may appear in the eyes. To prevent this, select **Red Eye** or **Red Eye Fix**.

Available in the AUTO, PROGRAM, NIGHT, BEAUTY SHOT, and some SCENE modes

## Icons used in this manual

Icon	Function
	Additional information
	Situations where you need to be careful
[ ]	Camera buttons; for example: <b>[Shutter]</b> (represents the Shutter button)
( )	Page number for reference
→	The order of options or menus you must select to perform a step; for example: Touch > →  (represents >, followed by ).
*	Annotation

## Abbreviations used in this manual

Abbreviation	Definition
ACB	Auto Contrast Balance
AEB	Auto Exposure Bracket
AF	Auto Focus
DIS	Digital Image Stabilisation
DPOF	Digital Print Order Format
EV	Exposure Value
OIS	Optical Image Stabilisation
WB	White Balance

## Expressions used in this manual

### Pressing the shutter

- Half-press [**Shutter**]: press and hold the shutter halfway down
- Press [**Shutter**]: press the shutter all the way down

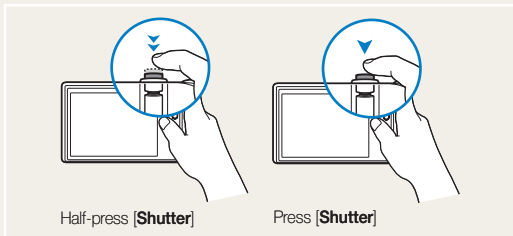

### Exposure (Brightness)

The amount of light that enters your camera is called exposure. You can alter the exposure with shutter speed, aperture value, and ISO speed. By altering the exposure, your photos will be darker or lighter.



Normal exposure

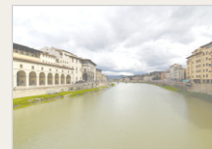

Overexposure (too bright)

### Subject, background, and composition

- Subject: the main object of a scene, such as a person, animal, or still life
- Background: the objects around the subject
- Composition: the combination of a subject and background

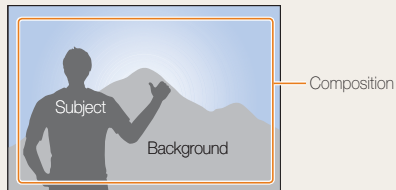

# Quick search



## Taking photos of people

- **SCENE** mode > PORTRAIT, CHILDREN, SELF SHOT ▶ 20
- mode ▶ 21
- Red Eye, Red Eye Fix (to prevent or correct red-eye) ▶ 33
- Face Detection, Self Portrait, Smile Shot, Blink Detection ▶ 38



## Taking photos at night or in the dark

- mode ▶ 20
- **SCENE** mode > DAWN, FIREWORK ▶ 20
- Flash options ▶ 33
- ISO speed (to adjust the sensitivity to light) ▶ 35



## Taking photos of an action

- Adjust shutter speed in the **M** mode ▶ 22
- Continuous, High Speed, M. Capture ▶ 44



## Taking photos of food, insects, or flowers

- **SCENE** mode > CLOSE UP, FOOD ▶ 20
- Macro, Auto Macro (to take close-up photos) ▶ 36
- White balance (to change the colour tone) ▶ 42



## Adjusting the exposure (brightness)

- Adjust exposure in the **M** mode ▶ 22
- ISO speed (to adjust the sensitivity to light) ▶ 35
- EV (to adjust exposure) ▶ 40
- ACB (to compensate for subjects against bright backgrounds) ▶ 41
- Metering ▶ 42
- AEB (to take three photos of the same scene with different exposures) ▶ 44



## Applying a different effect

- Photo Style (to apply a different tone) ▶ 45
- Effect (to apply a different colour filter) ▶ 45
- Adjust saturation, sharpness, or contrast ▶ 46



















## Reducing camera shake







- Optical Image Stabilisation (OIS) ▶ 18
- **DUAL** mode ▶ 21

- Deleting all files in the memory card ▶ 50
- Viewing files in a slide show ▶ 52
- Viewing files on a TV or HDTV ▶ 59
- Connecting your camera to a computer ▶ 61
- Adjusting sound and volume ▶ 69
- Adjusting the brightness of the display ▶ 69
- Changing the language displayed on the screen ▶ 69
- Setting the date and time ▶ 69
- Formatting the memory card ▶ 70
- Troubleshooting ▶ 76



# Contents

1. Basic functions .....	10	3. Shooting options .....	29
Camera layout .....	11	Selecting a resolution and quality .....	30
Icons .....	13	Selecting a resolution .....	30
Turning your camera on or off .....	14	Selecting a quality .....	31
Using the touch screen .....	15	Using the timer and remote control .....	32
Setting the display .....	16	Shooting in the dark .....	33
Taking photos .....	17	Preventing red-eye  .....	33
Zooming .....	17	Using the flash .....	33
Reducing camera shake (OIS)  .....	18	Adjusting the ISO speed  .....	35
2. Extended functions .....	19	Changing the camera's focus .....	36
Shooting modes .....	20	Using macro  .....	36
<b>AUTO</b> Using the Auto mode .....	20	Using auto focus  .....	36
 Using the Night mode .....	20	Using touch focus  .....	37
<b>SCENE</b> Using the Scene mode .....	20	Adjusting the focus area  .....	37
 <b>DUAL</b> Using the Dual IS mode .....	21	Using face detection .....	38
 Using the Beauty Shot mode .....	21	Adjusting brightness and colour .....	40
<b>P</b> Using the Program mode .....	22	Adjusting the exposure manually  .....	40
<b>M</b> Using the Manual mode .....	22	Compensating for backlighting  .....	41
 Recording a video .....	24	Changing the metering option  .....	42
Tips for getting a clearer photo .....	26	Selecting a light source (White balance)  .....	42
Recording voice memos .....	28	Using burst modes .....	44
Recording a voice memo .....	28	Improving your photos .....	45
Adding a voice memo to a photo .....	28	Applying photo styles  .....	45
		Applying colour  .....	45
		Adjusting your photos .....	46

<b>4. Playback/Editing</b> .....	47
<b>Playing back</b> .....	48
Starting Playback mode .....	48
Viewing photos .....	51
Playing a video .....	53
Playing voice memos .....	54
<b>Editing a photo</b> .....	55
Rotating a photo .....	55
Resizing photos .....	55
Editing colour .....	56
Applying a special effect .....	56
Correcting exposure problems .....	57
Creating a print order  .....	58
<b>Viewing files on a TV or HDTV</b> .....	59
<b>Transferring files to your computer</b> .....	61
For Windows users .....	61
For Mac users .....	64
<b>Printing photos with a photo printer</b>  .....	65
<b>5. Appendix</b> .....	67
<b>Camera settings menu</b> .....	68
Accessing the settings menu .....	68
Sound setting  .....	69
Display setting  .....	69
Camera setting  .....	70
Connection setting  .....	71
<b>Error messages</b> .....	72
<b>Camera maintenance</b> .....	73
Cleaning your camera .....	73
About memory cards .....	74
About the battery .....	75
<b>Before contacting a service centre</b> .....	76
<b>Camera specifications</b> .....	79
<b>Index</b> .....	83



# 1. *Basic functions*

Learn about your camera's layout, icons, and basic functions for shooting.

Camera layout .....	11
Icons .....	13
Turning your camera on or off .....	14
Using the touch screen .....	15
Setting the display .....	16
Taking photos .....	17
Zooming .....	17
Reducing camera shake (OIS) .....	18

# Camera layout

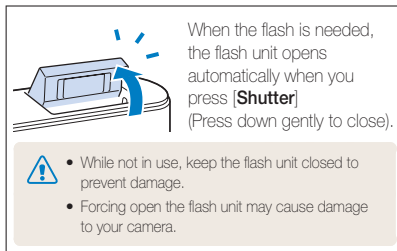
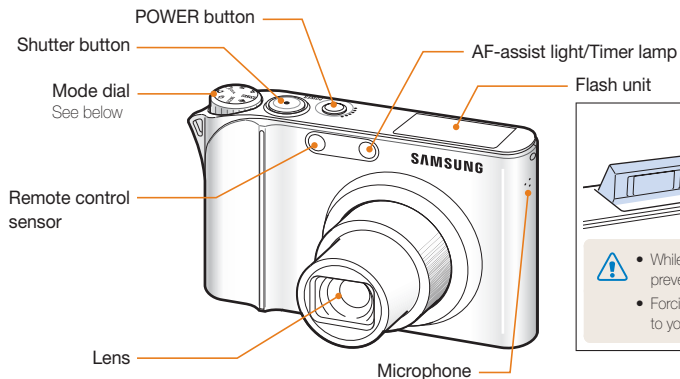

Icon	Mode	Description
<b>AUTO</b>	AUTO	Take a photo quickly and easily with minimal settings
<b>P</b>	PROGRAM	Take a photo by setting options (except for shutter speed and aperture value)
<b>M</b>	MANUAL	Take a photo by setting options manually
<b>DUAL IS</b>	DUAL IS	Take a photo with options suitable for reducing camera shake

Icon	Mode	Description
<b>NIGHT</b>	NIGHT	Take a photo with options for shooting at night
<b>BEAUTY SHOT</b>	BEAUTY SHOT	Take a photo of a person with options to hide facial imperfections
<b>SCENE</b>	SCENE	Take a photo with options for a preset scene
<b>MOVIE</b>	MOVIE	Record a video

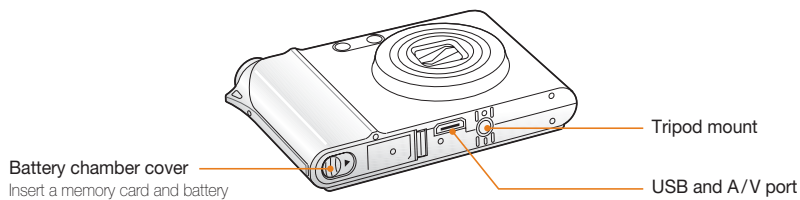
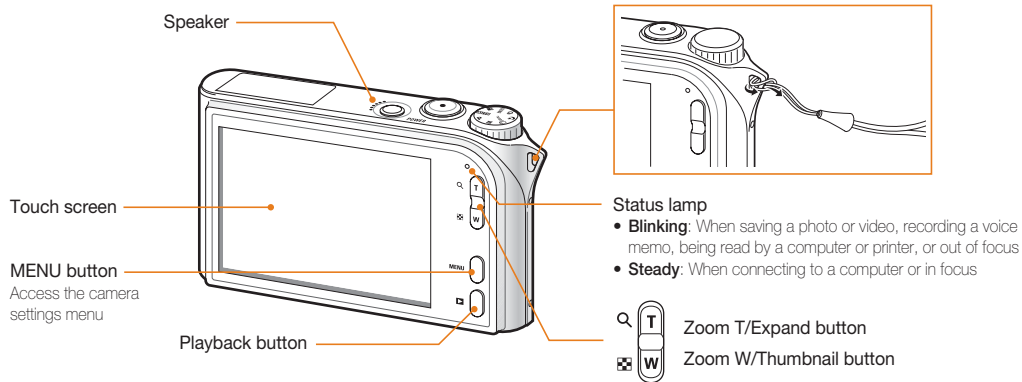

# Icons

The icons displayed will change according to the selected mode or options you set.

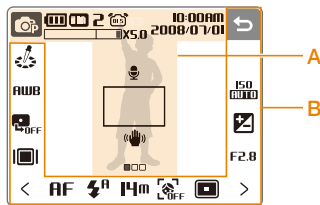

## A. Main display

Icon	Description
	Selected shooting mode
	: Fully charged : Partially charged : Charging needed
	Internal memory
	Memory card inserted
	Available number of photos
	Available recording time
	Optical Image Stabilisation (OIS)
	Current date and time
	Zoom ratio
	Voice memo
	Auto focus frame
	Camera shake
	Option set 1 (of 3)

## B. Touch icons

Icon	Description
	Selected photo style
	Select a white balance
	Adjust the exposure with ACB
	Select a display type
	Return to the previous screen
	Select a scene
	Select an ISO speed
	Adjust the brightness of the face
	Adjust the exposure manually
	Adjust the shutter speed
	Adjust imperfections of the face
	Select an aperture value
	Select an auto focus option
	Select a flash option
	Select a video resolution
	Select a photo resolution

Icon	Description
	Select a frame rate
	Select a face detection option
	Select a focus area option
	Select a burst type
	Select a metering option
	Select photo quality
	Select a timer option
	Add a voice memo to a photo or record a voice memo
	Set the Optical Image Stabilisation option
	Apply a colour effect
	Adjust sharpness
	Adjust contrast
	Adjust saturation
	Display another row of options

# Turning your camera on or off

Press **[POWER]** to turn your camera on or off.

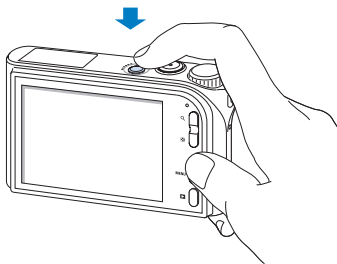

## In Playback mode

Press **[Playback]** to view stored files.



Press and hold **[Playback]** to mute camera sounds.

# Using the touch screen

Learn basic actions to use the touch screen. The touch screen works best when touched with the soft part of your finger.

 Do not use any sharp objects to touch the screen. Doing so may damage the screen.

## Touching

Touch an icon to open a menu or set an option.

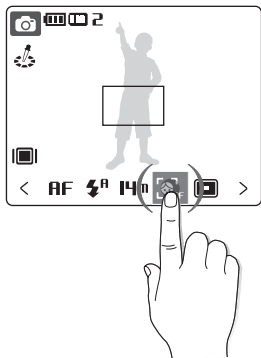

-  The screen may not recognise your touches correctly when:
- you touch multiple items at the same time
  - you use the camera in high humidity environments or with a wet finger
  - you use the camera with an LCD protection film or another LCD accessory

## Dragging

Drag your finger left or right to scroll horizontally.

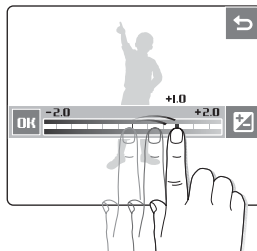

Drag your finger up or down to scroll vertically.

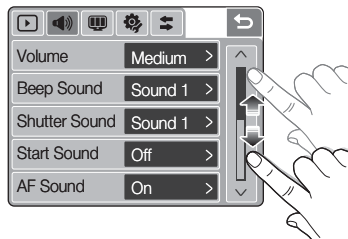





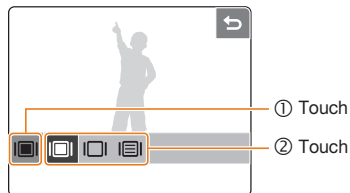

## Setting the display

### Selecting a display type



Select a style of display for Shooting or Playback mode.



Option	Available mode	Description
 Full	Shooting, Playback	Display the name of an option when you touch an icon.
<input type="checkbox"/> Hide	Shooting, Playback	Hide icons on the screen if you perform no operations for 3 seconds (touch the screen to display icons again).
 Basic	Playback	Display icons without the name of an option.
 Function Description	Shooting	Display the name of an option and a brief description when you touch an icon.

### Setting a start image

Set a start image to be displayed when the camera is turned on.

- 1 In Playback mode, press **[MENU]**.
- 2 Touch  → **Start Image** → **User Image**.
- 3 Touch .
- 4 Select a photo and touch .
  - If there are no images, you must first take a photo.
- 5 Set a start image.

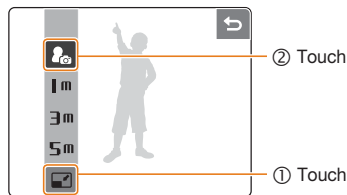

- Only one start image will be saved in the internal memory.
- If you select a new photo as a start image or reset your camera, the current image will be deleted.
- A wide image or image in 3:2 ratio cannot be set as a start image.

# Taking photos

- 1 Rotate the mode dial to **AUTO**.



- 2 Align your subject in the frame.

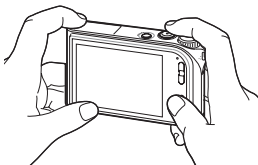

- 3 Half-press [Shutter] to focus.

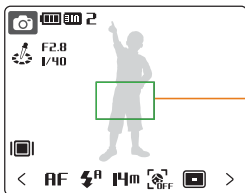

- Green: In focus
- Red: Out of focus

- 4 Press [Shutter] to take a photo.

## Zooming

You can shoot close-up photos by adjusting the zoom. Your camera has a 3.6X optical zoom and 5X digital zoom. By using both, you can zoom in up to 18 times.

Press or press and hold [T] to zoom in on your subject. Press or press and hold [W] to zoom out.

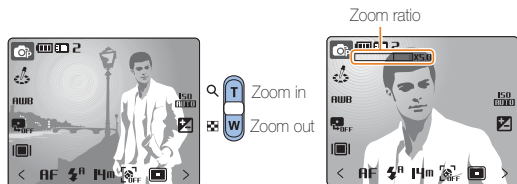

### Digital zoom

If the zoom indicator is in the digital range, your camera is using the digital zoom. The picture quality may deteriorate when you use the digital zoom.

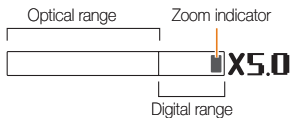

- The digital zoom is not available when using **DUAL**, **C**, **Q**, **SCENE** (in some scenes), and **AF** modes and when used with **High Speed**, **M. Capture**, or **Face Detection**.
- It may take longer to save a photo when using the digital zoom.
- The focus area will be set to **Center AF** when using the digital zoom.

### Reducing camera shake (OIS)

Reduce camera shake optically in Shooting mode.

1 In Shooting mode, touch **>** → **OIS**.  
(In some modes, touch **>** twice.)

2 Set an option.

- If you set the option to on, **OIS** will appear on top of the screen.

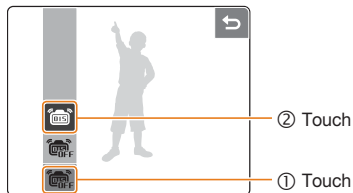



- Optical Image Stabilisation (OIS) may not function properly when:
  - you move your camera to follow a moving subject
  - you use digital zoom
  - there is too much camera shake
  - the shutter speed is slow (e.g., when shooting in the **C** mode)
  - the battery is low
  - you take a close-up shot
- If you use the OIS function with a tripod, your images may be blurred by the vibration of the OIS sensor. Deactivate the OIS function when you use a tripod.

## 2. Extended functions



Learn how to take a photo by selecting a mode and how to record a video or voice memo.

<b>Shooting modes</b> .....	20
<b>AUTO</b> Using the Auto mode .....	20
 Using the Night mode .....	20
<b>SCENE</b> Using the Scene mode .....	20
 <b>DUAL</b> Using the Dual IS mode .....	21
 Using the Beauty Shot mode .....	21
<b>P</b> Using the Program mode .....	22
<b>M</b> Using the Manual mode .....	22
 Recording a video .....	24
Tips for getting a clearer photo .....	26
<b>Recording voice memos</b> .....	28
Recording a voice memo .....	28
Adding a voice memo to a photo .....	28

# Shooting modes

Take photos or record videos by selecting the best shooting mode for the conditions.

## **AUTO** Using the Auto mode

Select **AUTO** to take a photo quickly and easily with minimal settings.

- 1 Rotate the mode dial to **AUTO**.
- 2 Align your subject in the frame and half-press [**Shutter**] to focus.
- 3 Press [**Shutter**] to take the photo.

## **★** Using the Night mode

Select **★** to take a photo with options for shooting at night. Use a tripod to prevent your camera from shaking.

- 1 Rotate the mode dial to **★**.
- 2 Align your subject in the frame and half-press [**Shutter**] to focus.
- 3 Press [**Shutter**] to take the photo.

## **SCENE** Using the Scene mode

Select **SCENE** to take a photo with options for a preset scene.

- 1 Rotate the mode dial to **SCENE**.
- 2 Touch .
- 3 Select a scene.

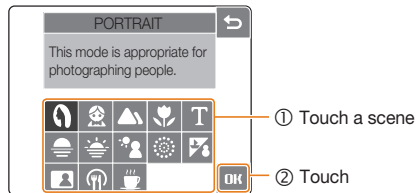

- 4 Align your subject in the frame and half-press [**Shutter**] to focus.
- 5 Press [**Shutter**] to take the photo.

## DUAL Using the Dual IS mode

Reduce camera shake and prevent blurred photos with Optical and Digital Image Stabilisation functions.

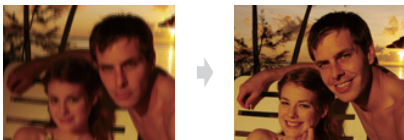

Before correction

After correction

- 1 Rotate the mode dial to  DUAL.
- 2 Align your subject in the frame and half-press [Shutter] to focus.
- 3 Press [Shutter] to take the photo.
  - Do not move your camera while **Capturing!** is displayed on the screen.



- The digital zoom will not work in this mode.
- The photo will be corrected optically only when taken with a light source that is brighter than fluorescent light.
- If your subject is moving rapidly, the photo may be blurry.
- Set the Optical Image Stabilisation option to reduce camera shake in different shooting modes. (p. 18)

## Using the Beauty Shot mode

Select  to take a photo of a person with options to hide facial imperfections.

- 1 Rotate the mode dial to .
- 2 Adjust the brightness of the face.

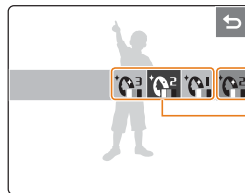

① Touch

② Touch

As the number increases, the face appears brighter.

- 3 Adjust facial imperfections.

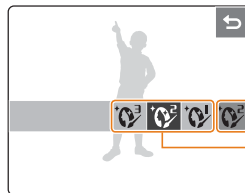

① Touch

② Touch

As the number increases, the face becomes clearer.

- Align your subject in the frame and half-press **[Shutter]** to focus.
- Press **[Shutter]** to take the photo.

## P Using the Program mode

Set various options (except for shutter speed and aperture value) in the Program mode.

- Rotate the mode dial to **P**.
- Set options. (For a list of options, refer to Chapter 3 'Shooting options.')

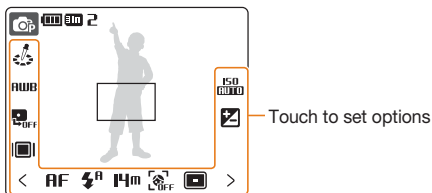

- Align your subject in the frame and half-press **[Shutter]** to focus.
- Press **[Shutter]** to take the photo.

## M Using the Manual mode

Set options (including shutter speed and aperture value) in the Manual mode. With these two options, you can adjust exposure and represent the photo in different ways as well.

### Shutter speed

Shutter speed is the length of time that a camera shutter remains open. When you use a slower shutter speed, light enters your camera for a longer time, which makes the photo brighter. You will get a darker photo with a fast shutter speed.

When using a slow shutter speed, moving subjects may appear blurry. When using a fast shutter speed, you can freeze a fast-moving subject.



Slow shutter speed



Fast shutter speed

## Aperture value

As the aperture value is increased, your camera lets less light in, which makes the photo darker. Alternatively, as the aperture value is reduced, your camera lets more light in, which makes the photo brighter.

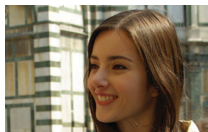

Big aperture value

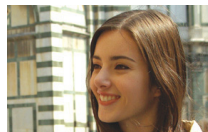

Small aperture value

1 Rotate the mode dial to **M**.

2 Select a shutter speed.

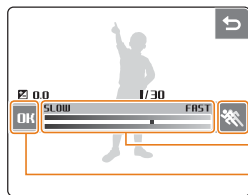

- ① Touch
- ② Drag left or right
- ③ Touch

3 Select an aperture value.

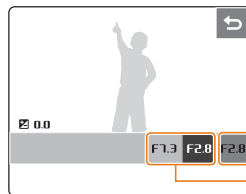

- ① Touch
- ② Touch

4 Set other options as desired. (For options, refer to Chapter 3 'Shooting options.')

5 Align your subject in the frame and half-press **[Shutter]** to focus.

6 Press **[Shutter]** to take the photo.



As the shutter speed or aperture value changes, the exposure value **0.0** will change accordingly.



## Recording a video

Record videos of up to 20 minutes in length in high definition (1280 X 720 resolution). The recorded video is saved as an H.264 (MPEG4.AVC) file.



- H.264 (MPEG4 part10/AVC) is a high-compression video format established by international standard organisations ISO/IEC and ITU-T.
- Some memory cards may not support high definition recording. In this case, set a lower resolution. (p. 30)
- When the Optical Image Stabilisation () is activated, your video may be recorded with the OIS operation sound.
- The zoom sound may be recorded if you use the zoom while recording a video.

1 Rotate the mode dial to .

2 Select a frame rate (the number of frames per second).

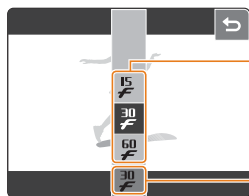

② Touch

As the number of frames increases, action appears more natural, but the file size is increased.

① Touch



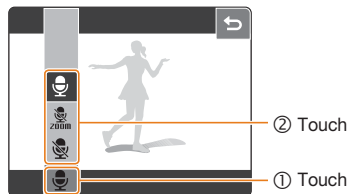

When **60 FPS** is selected, the video will be recorded at 320x240 resolution.

3 Touch  and select a sound option.



② Touch

① Touch

Option	Description
 Off	Record a video without sound.
 Zoom Mute	Record a video without sound while zooming.
 On	Record a video with sound.

- 4 Set other options as desired.  
(For options, refer to Chapter 3 'Shooting options.')
- 5 Press **[Shutter]**.
- 6 Press **[Shutter]** again to stop recording.

#### To pause while recording a video

The camera allows you to pause temporarily while recording a video. With this function, you can record your favourite scenes as a single video.



Touch to pause while recording  
(Touch again to resume.)

## Tips for getting a clearer photo

### Holding your camera correctly

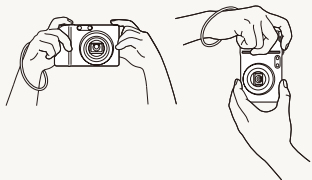

Make sure nothing is blocking the lens.

### Half-pressing the shutter button

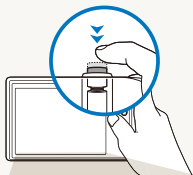

Half-press **[Shutter]** and adjust the focal point. Focus and exposure will be adjusted automatically or the flash will pop up if necessary.

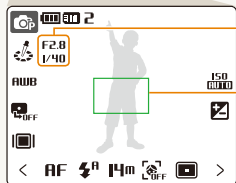

The aperture value and shutter speed are automatically set.

#### Focus frame

- Press **[Shutter]** to take the photo if displayed in green.
- Change the frame and half-press **[Shutter]** again if displayed in red.

### Reducing camera shake



- Set the Optical Image Stabilisation option to reduce camera shake optically. (p. 18)
- Select the  **DUAL** mode to reduce camera shake both optically and digitally. (p. 21)

### When is displayed

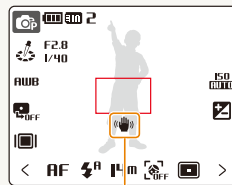

Camera shake

When shooting in the dark, avoid setting the flash option to **Slow Sync** or **Off**. The aperture remains open longer and it may be harder to hold the camera still.

- Use a tripod or set the flash option to **Fill in**. (p. 33)
- Set ISO speed options. (p. 35)

## ☺ Preventing your subject from being out of focus

- It is hard to get your subject in focus when:
  - there is little contrast between the subject and background  
(When your subject is wearing a colour of clothing that is similar to the background)
  - the light source behind the subject is too bright
  - your subject is shiny
  - your subject includes horizontal patterns, such as blinds
  - the subject is not positioned in the centre of the frame



### Use the focus lock

Half-press **[Shutter]** to focus. When the subject is in focus, you can reposition the frame to change the composition. When you are ready, press **[Shutter]** completely to take your photo.

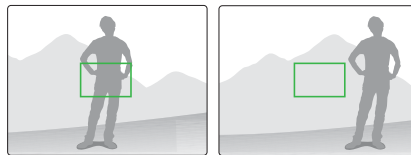

- When you take photos in low light

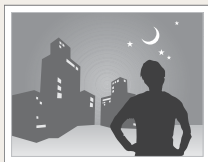

Turn the flash on.  
(p. 33)

- When subjects are moving fast

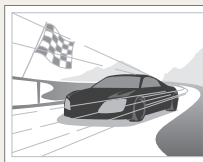

Use the continuous,  
high speed or motion  
capture. (p. 44)

# Recording voice memos

Record a voice memo that you can play back at any time or add a voice memo to a photo as a short reminder of shooting conditions.

 You will get the best sound quality when recording 40 cm away from the camera.

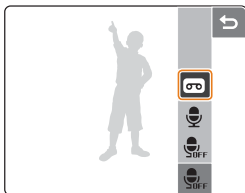

## Recording a voice memo

- 1 In Shooting mode (except ) , touch >.
- 2 Touch  → .



- 3 Press **[Shutter]** to record.
  - The available recording time will be displayed on top of the screen.
  - You can record voice memos of up to 10 hours in length.
- 4 Press **[Shutter]** to stop.
  - Press **[Shutter]** again to record a new voice memo.
- 5 Touch  to switch to Shooting mode.

## Adding a voice memo to a photo

- 1 In Shooting mode (except ) , touch >.
- 2 Touch  → .

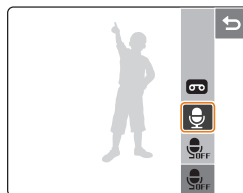

- 3 Align your subject in the frame and take a photo.
  - You will begin recording a voice memo right after taking the photo.
- 4 Record a short voice memo (10 seconds maximum).
  - Press **[Shutter]** to stop recording a voice memo.

# 3. Shooting options

Learn about the options you can set in shooting mode.

<b>Selecting a resolution and quality</b> .....	30
Selecting a resolution .....	30
Selecting a quality .....	31
<b>Using the timer and remote control</b> .....	32
<b>Shooting in the dark</b> .....	33
Preventing red-eye .....	33
Using the flash .....	33
Adjusting the ISO speed .....	35
<b>Changing the camera's focus</b> .....	36
Using macro .....	36
Using auto focus .....	36
Using touch focus .....	37
Adjusting the focus area .....	37
<b>Using face detection</b> .....	38
<b>Adjusting brightness and colour</b> .....	40
Adjusting the exposure manually .....	40
Compensating for backlighting .....	41
Changing the metering option .....	42
Selecting a light source (White balance) .....	42
<b>Using burst modes</b> .....	44
<b>Improving your photos</b> .....	45
Applying photo styles .....	45
Applying colour .....	45
Adjusting your photos .....	46

# Selecting a resolution and quality



## Selecting a resolution **AUTO P M** **SCENE**

As you increase the resolution, your photo or video has more pixels in it, so it can be printed on larger paper or displayed on a larger screen. When you use a high resolution, the file size will also increase.

### When taking a photo:

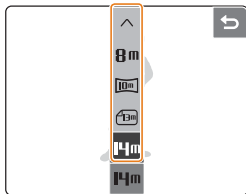
- 1 In Shooting mode, touch **14m**.
- 2 Select a resolution.





Option	Description
<b>14m</b>	4384x3288 Print on A1 paper.
 <b>13m</b>	4384x2920 Print on A1 paper in wide ratio (3:2).
 <b>10m</b>	4384x2464 Print on A2 paper or playback on an HDTV.
<b>8m</b>	3264x2448 Print on A3 paper.

Option	Description
<b>5m</b>	2592x1944 Print on A4 paper.
 <b>2m</b>	1920x1080 Print on A5 paper or playback on an HDTV.
<b>1m</b>	1024x768 Attach to an email or post on a Web page.

### When recording a video:

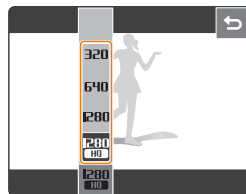

- 1 In the  mode, touch **1280 HD**.
- 2 Select a resolution.
  - For HD quality, select 1280x720HQ or 1280x720.



Option	Description
 <b>1280</b>	1280x720 Playback high-quality files on an HDTV.
<b>1280</b>	1280x720 Playback on an HDTV.
<b>640</b>	640x480 Playback on a general TV.
<b>320</b>	320x240 Post on a Web page.

## Selecting a quality **AUTO P M** **SCENE**

Photos you take are compressed and saved in a JPG format. The higher quality you select, the better photos you will get, but the file size will also increase.

- 1 In Shooting mode, touch **>** → .  
(In some modes, touch .)
- 2 Select a photo quality.

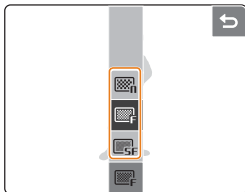

Option	Description
 <b>Super Fine</b>	Super fine quality
 <b>Fine</b>	Fine quality
 <b>Normal</b>	Normal quality



# Using the timer and remote control

AUTO P M SCENE

1 In Shooting mode, touch  $\rightarrow$  .

2 Select a timer option.

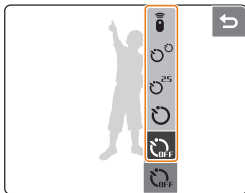

Option	Description
Off	The timer is not active.
10 Sec	Take a photo in 10 seconds.
2 Sec	Take a photo in 2 seconds.
Double	Take a photo in 10 seconds and take another in 2 seconds.

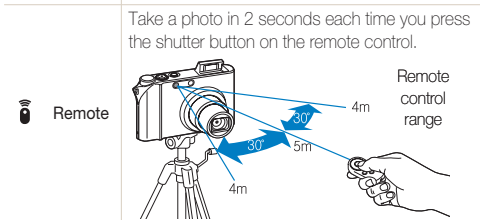

3 Press [**Shutter**] to start the timer.

- The timer lamp blinks. The camera will automatically take a photo after the specified time.

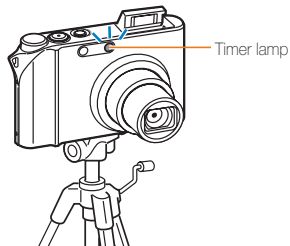

- Touch the timer icon to cancel the timer.
- When **Smile Shot** or **Blink Detection** is set, the timer is not available.

# Shooting in the dark

## Preventing red-eye **AUTO P** **SCENE**

If the flash fires when you take a photo of a person in the dark, a red glow may appear in the eyes. To prevent this, select **Red Eye** or **Red Eye Fix**.







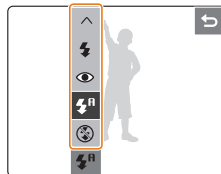

## Using the flash **AUTO P M** **SCENE**

Use the flash when taking photos in the dark.

- 1 In Shooting mode, touch .
- 2 Select a flash option.



Option	Description
 Off	<ul style="list-style-type: none"><li>• The flash will not fire.</li><li>• Camera shake warning () is displayed in the dark.</li></ul>
 Auto	The flash fires when the subject or background is dark.
 Red Eye*	<ul style="list-style-type: none"><li>• The flash fires when the subject or background is dark.</li><li>• The camera reduces red-eye.</li></ul>
 Fill in	<ul style="list-style-type: none"><li>• The flash always fires.</li><li>• Light intensity is adjusted automatically.</li></ul>

Option	Description
 <b>Slow Sync</b>	<ul style="list-style-type: none"> <li>• The flash fires and the shutter stays open longer.</li> <li>• Select this in the evening or in the dark.</li> <li>• It is a good idea to use a tripod to prevent your photos from blurring.</li> </ul>
 <b>Red Eye Fix*</b>	<ul style="list-style-type: none"> <li>• The flash fires when the subject or background is dark.</li> <li>• The camera corrects red-eye through its advanced software analysis.</li> </ul>

The options may differ depending on the shooting mode.

\* There is an interval between two bursts of the flash. Do not move until the flash fires a second time.



- Flash options are not available if you set burst options or select **Self Portrait** or **Blink Detection**.
- Make sure that your subjects are within the recommended distance from the flash. (p. 79)
- If there is reflected light or much dust in the air, tiny spots may appear on your photo.

### How to use the flash

Half-pressing **[Shutter]** will pop the flash up when it is needed. Pressing **[Shutter]** will cause the flash to fire and will take a photo.

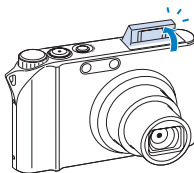

- While not in use, keep the flash unit closed to prevent damage.
- Forcing open the flash unit may cause damage to your camera.

Press down gently to close.

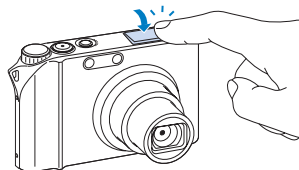

## Adjusting the ISO speed P M

ISO speed is the measure of a film's sensitivity to light as defined by the International Organisation for Standardisation (ISO). The higher ISO speed you select, the more sensitive to light your camera becomes. With a higher ISO speed, you can get a better photo without using the flash.

- 1 In Shooting mode, touch **ISO**.
- 2 Select an ISO speed option.
  - Select **ISO** to use an appropriate ISO speed based on the brightness of the subject and lighting.

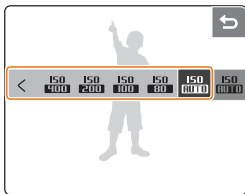

- The higher ISO speed you select, the more image noise you may get.
- When **High Speed**, **M. Capture**, **AEB**, **Blink Detection**, or **ACB** is set or **M** mode is selected, some ISO speed options are not available.
- When you set the ISO speed to 3200, the resolution will be set to 3M.

# Changing the camera's focus

## Using macro **AUTO P M**

Select **Macro** or **Auto Macro** to take close-up photos of subjects, such as flowers or insects.





- Try to hold the camera very still to prevent blurry photos.
- Turn the flash off if the distance to the subject is less than 40cm.

## Using auto focus **AUTO P M**

To take sharp photos, select the appropriate focus according to your distance from the subject.

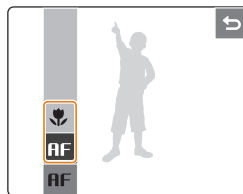
- 1 In Shooting mode, touch **AF**.
- 2 Select a focus distance option.



Option	Description
<b>AF</b> Normal (AF)	Focus on a subject farther than 80cm.
 Macro	Focus on a subject between 5 to 80cm (between 50 and 80cm while using zoom).
 Auto Macro	Focus on a subject farther than 5 cm (farther than 50 cm while using zoom).

The options may differ depending on the shooting mode.

## Using touch focus **P M**

You can focus on a particular part of your scene. Touch where you want to focus. Set the focus area to **Touch AF**.

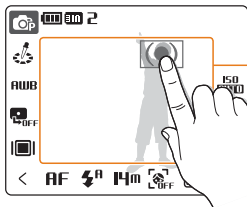

The frame will move to the location that you touch on the screen.







- When you do not touch any area on the screen, the frame will be in the centre of the screen.
- When you set the face detection option, this feature will not be available.

## Adjusting the focus area **AUTO P M** **SCENE**

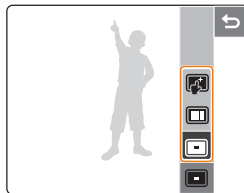
You can get clearer photos by selecting an appropriate focus area according to your subject's location in the scene.

- 1 In Shooting mode, touch .
- 2 Select a focus area option.



Option	Description
 <b>Center AF</b>	Focus on the centre (suitable when subjects are located in the centre).
 <b>Multi AF</b>	Focus on one or more of nine possible areas (when the digital zoom is in use, the focus will change to <b>Center AF</b> ).
 <b>Touch AF</b>	Focus on the point that you touch on the screen.

The options may differ depending on the shooting mode.



# Using face detection



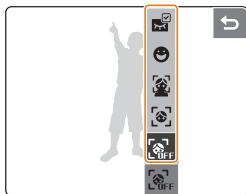

AUTO P M  SCENE

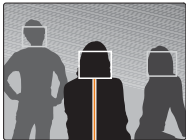

If you use face detection options, your camera can automatically detect a human face. When you focus on a human face, the camera adjusts the exposure automatically. Take photos quickly and easily by using Blink Detection to detect closed eyes or Smile Shot to capture a smiling face.

- 1 In Shooting mode, touch .
- 2 Select a face detection option.



Option	Description
 Off	Face detection is not active.
 Face Detection	<p>Your camera automatically detects human faces (up to ten human faces).</p>  <p>The closest face appears in a white focus frame and the rest of the faces appear in gray focus frames.</p> <ul style="list-style-type: none"><li>• The closer you are to the subject, the quicker your camera will detect faces.</li><li>• If your camera fails to detect a face, it will focus in the centre.</li></ul>

Option	Description
 Self Portrait	<p>Take photos of yourself. The focus distance will be set to close-up and your camera will emit a beep.</p>  <p>When you hear a quick beep, press <b>[Shutter]</b>.</p> <div style="border: 1px solid #ccc; padding: 5px; margin-top: 10px;">  To turn the beep on or off, select <b>Self Portrait</b> in the sound settings. (p. 69)         </div>
 Smile Shot	<p>The camera automatically releases the shutter when it detects a smiling face.</p>  <p>When your subject smiles broadly, your camera can detect the smile more easily.</p>

Option	Description
 Blink Detection	<p>If your camera detects closed eyes, it will take three photos in succession.</p>  <div style="border: 1px solid #ccc; padding: 5px; margin-top: 10px;">  When <b>'Picture taken with eyes closed'</b> message appears, take another photo.         </div>

The options may differ depending on the shooting mode.

- 
  - Face detection may not be effective when:
    - the subject is far from the camera (The focus frame will appear orange for Smile Shot and Blink Detection)
    - it is too bright or too dark
    - the subject is not facing the camera
    - the subject is wearing sunglasses or a mask
  - Face detection is not available when using a photo effect or photo style.
  - When you use the face detection option, the digital zoom will not work.
  - When **Smile Shot** or **Blink Detection** is set, the timer is not available.
  - When you use the face detection option, the focus area will be set to **Center AF**.



# Adjusting brightness and colour

## Adjusting the exposure manually

Depending on the intensity of the ambient light, your photos may be too bright or dark. In these cases, you can adjust the exposure to get a better photo.



Darker (-)



Neutral



Brighter (+)

1 In Shooting mode, touch .

2 Drag left or right to adjust the exposure.

- +: brighter, -: darker

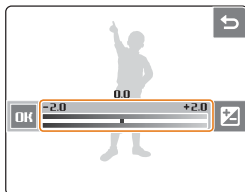

3 Touch **OK**.

- The adjusted exposure value will appear as shown below.

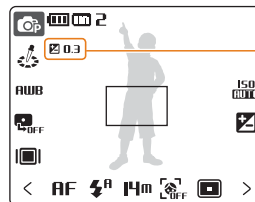

Adjusted exposure value



- Once you adjust the exposure, the setting will remain the same. You may need to change the exposure value to avoid overexposure or underexposure.
- If you cannot decide on an appropriate exposure, select **AEB** (Auto Exposure Bracket). The camera takes photos with different exposures: normal, underexposed, overexposed. (p. 44)

## Compensating for backlighting P M

When the light source is behind your subject or there is high contrast between your subject and the background, your subject is likely to appear dark in the photo. In this case, set the Auto Contrast Balance (ACB) option.





Without ACB

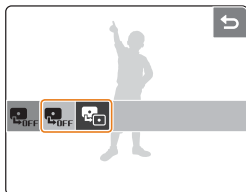

With ACB

- 1 In Shooting mode, touch .
- 2 Select an ACB option.



Option	Description
 Off	ACB is off.
 On	ACB is on.



- The ACB feature is always on in the **AUTO** mode.
- When the ACB feature is on, **High Speed**, **M. Capture**, **AEB**, or some ISO speed options are not available.

## Changing the metering option **P M**

The metering mode refers to the way in which a camera measures the quantity of light. The brightness and lighting of your photos will vary depending on the metering mode you select.

- 1 In Shooting mode, touch **>** → **[■]**.  
(In the  mode, touch **[■]**.)

- 2 Select a metering option.

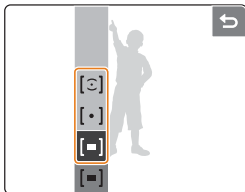

Option	Description
<b>[■]</b> Multi	<ul style="list-style-type: none"> <li>• Your camera divides the scene into several areas, and then measures the light intensity of each area.</li> <li>• Suitable for general photos.</li> </ul>
<b>[•]</b> Spot	<ul style="list-style-type: none"> <li>• Your camera measures only the light intensity of the very centre of the frame.</li> <li>• If a subject is not in the centre of the scene, your photo may come out too bright or dark.</li> <li>• Suitable for a subject with backlighting.</li> </ul>

Option	Description
<b>[☺]</b> Center Weighted	<ul style="list-style-type: none"> <li>• Your camera averages the meter reading of the entire frame with emphasis placed on the centre.</li> <li>• Suitable for photos with subjects in the centre of the frame.</li> </ul>

## Selecting a light source (White balance) **P M**

The colour of your photo depends on the type and quality of the light source. If you want the colour of your photo to be realistic, select an appropriate lighting condition to calibrate the white balance, such as Auto WB, Daylight, Cloudy, or Tungsten.



**AWB** (Auto WB)



 (Daylight)



 (Cloudy)



 (Tungsten)

- 1 In Shooting mode, touch **AWB**.
- 2 Select a white balance option.
  - Drag left or right to preview.

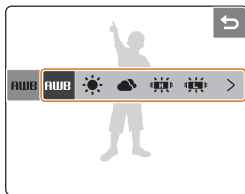

Icon	Description
<b>AWB</b> Auto WB	Use automatic settings depending on the lighting conditions.
Daylight	Select when taking outdoor photos on a sunny day.
Cloudy	Select when taking outdoor photos on a cloudy day or in shadows.
Fluorescent_H	Select when shooting under a daylight fluorescent or three-way fluorescent light.
Fluorescent_L	Select when shooting under white fluorescent light.

Icon	Description
Tungsten	Select when taking indoor photos under incandescent bulbs or halogen lamps.
Custom Set	Use your pre-defined settings.

You can set colour effect options to **Normal** or **Negative** when you select a white balance option (except for **Auto WB**). (p. 45)

### Defining your own white balance

- 1 From the white balance options, touch > → .
- 2 Aim the lens at a piece of white paper.

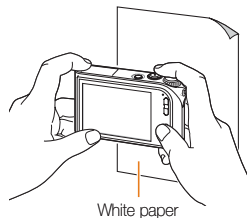

- 3 Press [**Shutter**].
  - Touch **FORMER** or to cancel.

# Using burst modes

P M SCENE

It can be difficult to take photos of fast-moving subjects or capture natural facial expressions and gestures of your subjects in photos. In these cases, select one of the burst modes.



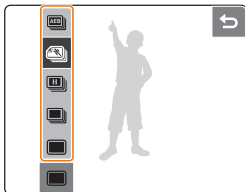

1 In Shooting mode, touch > → .

2 Select a burst option.



Option	Description
 <b>Single</b>	Take a single photo.
 <b>Continuous</b>	<ul style="list-style-type: none"><li>While [<b>Shutter</b>] is fully pressed down, the camera takes photos continuously.</li><li>The maximum number of photos depends on the capacity of your memory card.</li></ul>

Option	Description
 <b>High Speed</b>	<ul style="list-style-type: none"><li>While [<b>Shutter</b>] is fully pressed down, the camera takes three photos every two second.</li><li>The shooting speed may slow depending on the shooting conditions and the number of photos taken.</li></ul>
 <b>M. Capture</b>	<ul style="list-style-type: none"><li>While [<b>Shutter</b>] is fully pressed down, the camera takes 1 megabyte photos (15 photos per two second; maximum of 30 photos).</li><li>The camera automatically shows you the photos just taken and then saves them.</li></ul>
 <b>AEB</b>	<ul style="list-style-type: none"><li>Take three photos with different exposures: normal, underexposed, and overexposed.</li><li>It is best to use a tripod because it takes some time to save photos taken with AEB.</li></ul>

The options may differ depending on the shooting mode.

-  You cannot use the flash and timer unless you select **Single**.
- When you select **High Speed**, **M. Capture**, or **AEB**, the **ACB** or some ISO speed options are not available.
- When you select **High Speed** or **M. Capture**, the digital zoom is not available.
- When you select **M. Capture**, the resolution will be set to 1M.

# Improving your photos

## Applying photo styles **AUTO P M**

Apply different style to your photos, such as Soft, Vivid, or Forest.



Soft



Vivid



Forest

- 1 In Shooting mode, touch .
- 2 Select a photo style.
  - Drag left or right to preview.

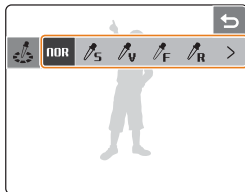

When you select a photo style, the white balance will be set to **Auto WB**.

## Applying colour **P M SCENE**

Apply different effects to your photos, such as B & W, Sepia, or Blue.





B & W



Sepia



Blue

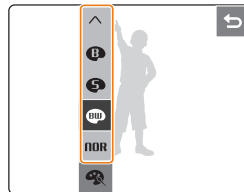

- 1 In Shooting mode, touch **>** twice → .
- (In some modes, touch .)
- 2 Select a colour effect.
  - Drag up or down to preview.







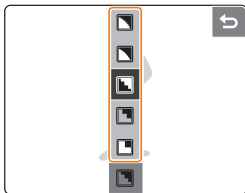

- Select **Normal** if you want to use face detection options, or any white balance settings.
- If you select a photo style (except for **Normal**), this feature is not available.

## Adjusting your photos P M

Adjust the sharpness, saturation, and contrast of your photos.

- 1 In Shooting mode, touch > twice.
- 2 Select an adjustment option.
  - : Sharpness
  - : Contrast
  - : Saturation
- 3 Select an option (e.g. Sharpness).



Sharpness option	Description
 /  <b>Vivid+/ Vivid</b>	Sharpen the edges to improve the clarity of your photos. This may also increase the noise on your photos.
 <b>Normal</b>	Do not apply any effect (suitable for printing).
 /  <b>Soft/ Soft+</b>	Soften the edges on your photos (suitable for editing the photos on your computer).

Contrast option	Description
 +	Increase the colour and brightness.
 -	Decrease the colour and brightness.
Saturation option	Description
 +	Increase the saturation.
 -	Decrease the saturation.



If you select a photo style (except for **Normal**), you cannot adjust contrast or saturation.

# 4. Playback/Editing

Learn how to play back photos, videos, or voice memos and edit photos or videos. You will also learn how to connect your camera to your computer, photo printer, TV, or HDTV.

<b>Playing back</b> .....	48
Starting Playback mode .....	48
Viewing photos .....	51
Playing a video .....	53
Playing voice memos .....	54
<b>Editing a photo</b> .....	55
Rotating a photo .....	55
Resizing photos .....	55
Editing colour .....	56
Applying a special effect .....	56
Correcting exposure problems .....	57
Creating a print order .....	58
<b>Viewing files on a TV or HDTV</b> .....	59
<b>Transferring files to your computer</b> .....	61
For Windows users .....	61
For Mac users .....	64
<b>Printing photos with a photo printer</b> .....	65



# Playing back

## Starting Playback mode

View photos or play videos and voice memos stored in your camera.

### 1 Press [Playback].

- The most recent file you have taken or recorded will be displayed.
- If the camera is off, it will turn on.

### 2 Drag your finger left or right to scroll through files.

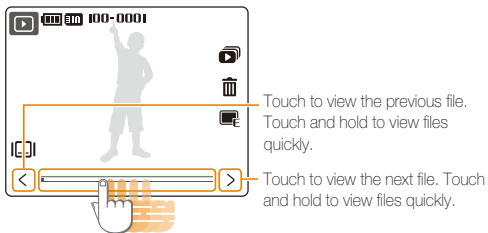

- If you want to view files stored in the internal memory, remove your memory card.
- You can use an optional remote control to play back files. (See the 'HDMI Cradle Manual')

## Display in Playback mode

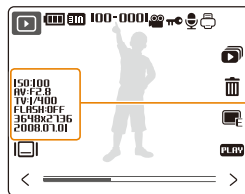

Information

Icon	Description
100-0001	Folder name – File name
	Video file
	Protected file
	Photo includes a voice memo
	Print order has been set (DPOF)
	Select a display type (p. 16)
	Slide show (p. 52)
	Delete files (p. 50)
	Edit menu for photos (p. 55)
	Play videos or voice memos (Video p. 53/Voice memo p. 54)

### Viewing files by date

View files by the date they were saved.

- 1 In Playback mode, press **[MENU]**.
- 2 Touch **View** → **Date**.
  - Touch **All** to view all files.
- 3 Select the date the file was saved.

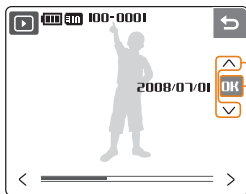

- ① Touch ^ or v to select the date
- ② Touch

- 4 Drag your finger left or right to scroll through files.
  - Touch **[1:1]** to change the date.

### Viewing files as thumbnails

Scan through files using thumbnails.

- In Playback mode, press **[W]** to enter the thumbnail view (press **[T]** to exit the thumbnail view).

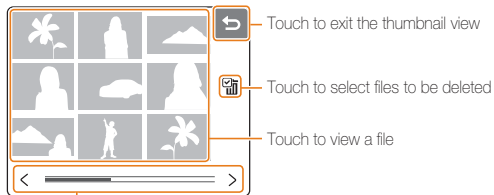

- Touch to exit the thumbnail view
- Touch to select files to be deleted
- Touch to view a file

- To scroll through files:
- touch < or >
  - drag the scrollbar left or right

### Protecting files

Protect your files from accidental deletion.

- 1 In Playback mode, press **[MENU]**.
- 2 Touch **Protect**.
- 3 Touch **Select** or **All**.
  - If you touch **All**, skip to step 5.
- 4 Select a file.

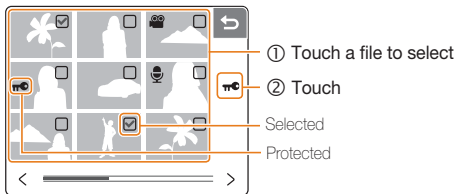

- 5 Touch **Lock**.
  - To unlock the file, touch **Unlock**.

### Deleting files

Delete single files or all files at once. You cannot delete protected files.

#### To delete a single file,

- 1 In Playback mode, select a file and touch .
- 2 Touch **Yes** to delete the file.

#### To delete all files,

- 1 In Playback mode, press **[MENU]**.
- 2 Touch **Delete** → **All**.
- 3 Touch **Yes** to delete all files.

#### Alternate way to delete a file

While viewing a file in Playback mode, draw an X on the screen. Touch **Yes** to delete the file.

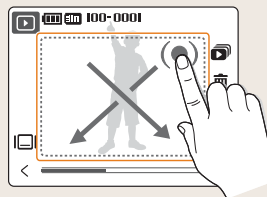

### Restoring photos from the recycle bin

If you activate the recycle bin, files you delete will be sent to the recycle bin instead of being deleted permanently (p. 70). This applies to single files or selected files only—if you choose to delete all files, those files will not be sent to the recycle bin.

The recycle bin will hold up to 10MB of files. Once you exceed the 10MB limit, files will be automatically deleted (the oldest file in the recycle bin will be deleted first).

1 In Playback mode, press [MENU].

2 Touch  → **Recycle Bin** → **Recycle Folder**.

- The restoration starts.
- Touch  to cancel the restoration.



- This function does not work for videos or voice memos.
- It may take longer to delete files when using the recycle bin function.
- If you format the internal memory, all files in the recycle folder will be deleted.
- To view files in the RECYCLE folder, connect your camera to your computer without a memory card.

### Copying files to the memory card

You can copy files from the internal memory to a memory card.

1 In Playback mode, press [MENU].

2 Touch **Copy to Card**.

3 Touch **Yes** to copy files.

## Viewing photos

View a photo by changing the orientation by touch, zoom in on part of a photo, or view photos in a slide show.

### Rotating a photo by touch

While viewing a single file, drag your finger as shown below to rotate the photo 90°.

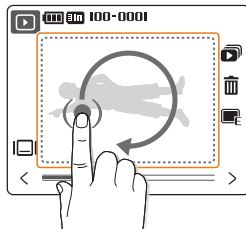

### Enlarging a photo

In Playback mode, press [T] to enlarge a photo (press [W] to reduce a photo).

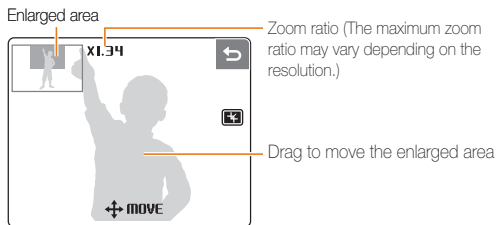

Icon	Description
	Crop the enlarged photo (it will be saved as a new file).
	Go back to the original view.

### Starting a slide show

You can apply effects and audio to your slide show.

- 1 In Playback mode, touch
- 2 Set a slide show effect.



Option	Description
<b>OFF</b> Effect	<ul style="list-style-type: none"> <li>• Select a transition effect.</li> <li>• Select <b>Off</b> for no effect.</li> </ul>
Interval	<ul style="list-style-type: none"> <li>• Set the interval between photos.</li> <li>• This will not be available when <b>Off</b> or <b>Basic</b> is selected in the <b>Effect</b> menu.</li> </ul>
Music	Select background audio.
Play Mode	Select whether or not to loop the slide show.

- 3 Touch to start the slide show.
  - Touch to pause the show.
  - Touch to switch to Playback mode.

## Playing a video

You can play a video, capture an image from a video, or crop a video.

- 1 In Playback mode, select a video and touch **PLAY**.
- 2 Use the following icons to control playback.

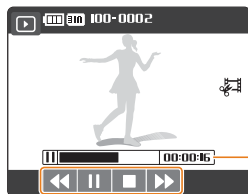

Elapsed time

Icon	Description
	<ul style="list-style-type: none"> <li>• Skip backward.</li> <li>• Touch and hold to scan backward (maximum scanning speed: 16 X).</li> </ul>
	Pause or resume playback.
	Stop playback.
	<ul style="list-style-type: none"> <li>• Skip forward.</li> <li>• Touch and hold to scan forward (maximum scanning speed: 16 X).</li> </ul>

## Cropping a video

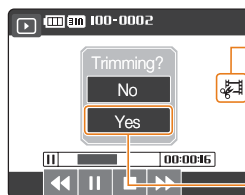

- ① Touch at the point where you want the new video to begin and touch again at the point where you want it to end.

- ② Touch



- The original video should be at least 5 seconds long.
- The edited video will be saved as a new file.

## Capturing an image during playback

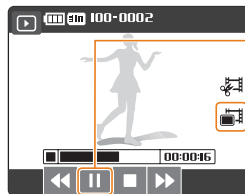

- ① Touch at the point where you want to save a still image.

- ② Touch (It will appear when you touch .)







- A captured image will have the same file size as the original video file and will be saved as a new file.

## Playing voice memos

### Playing a voice memo

- 1 In Playback mode, select a voice memo and touch **PLAY**.
- 2 Use the following icons to control playback.



Icon	Description
	<ul style="list-style-type: none"> <li>• Skip backward.</li> <li>• Touch and hold to scan backward.</li> </ul>
	Pause or resume playback.
	Stop playback.
	<ul style="list-style-type: none"> <li>• Skip forward.</li> <li>• Touch and hold to scan forward.</li> </ul>

### Playing a voice memo added to a photo

- 1 In Playback mode, select a photo that includes a voice memo and touch **PLAY**.
- 2 Use the following icons to control playback.



Icon	Description
	Pause or resume playback.
	Stop playback.

# Editing a photo

Perform photo editing tasks such as rotating, resizing, eliminating red eyes, and adjusting brightness, contrast, or saturation.

## Rotating a photo

- 1 In Playback mode, select a photo and touch .
- 2 Rotate the photo.

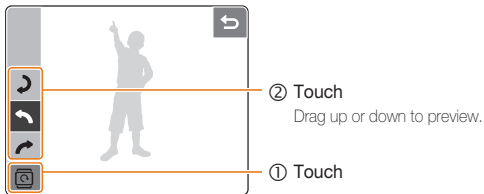

- 3 Touch **OK** to save the change.

## Resizing photos

You can reduce the size of a photo and save it as a new file.

- 1 In Playback mode, select a photo and touch .
- 2 Select a resolution.
  - Your change will be saved automatically.

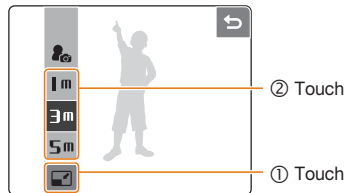



## Editing colour

Apply a different colour tone to the photo, such as B & W, Sepia, or Blue and save it as a new file.



B & W



Sepia



Blue

- 1 In Playback mode, select a photo and touch .
- 2 Select a colour tone.

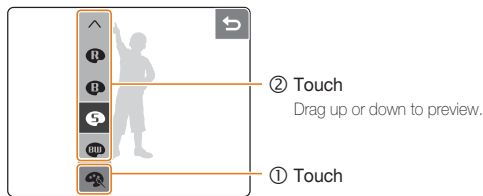





- 3 Touch **OK** to save the change.

## Applying a special effect

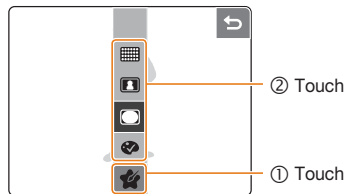
Apply special effects to the photo, such as colour filters or vignette effects.

- 1 In Playback mode, select a photo and touch .
- 2 Select a special effect.







Option	Description
 <b>Color Filter</b>	Change background colours to black and white to make the main subject stand out.
 <b>Shaded</b>	Apply a vignette effect that darkens the outer edges of an image in comparison to the centre of the image.
 <b>Elegant</b>	Apply effects to the photo to make it brighter and softer.
 <b>Add Noise</b>	Add noise to the photo to give it an aged look.

- 3 Touch **OK** to save the change.





## Correcting exposure problems

Adjust ACB (Auto Contrast Balance), brightness, contrast, or saturation; remove red eyes; or hide facial imperfections. Edited photos will be saved as new files.





### Adjusting ACB (Auto Contrast Balance)

- 1 In Playback mode, select a photo and touch .
- 2 Touch  →  → .
- 3 Touch **OK** to save the change.



### Removing red eyes

- 1 In Playback mode, select a photo and touch .
- 2 Touch  →  → .
- 3 Touch **OK** to save the change.

### Adjusting Brightness/Contrast/Saturation

- 1 In Playback mode, select a photo and touch .
- 2 Touch  and select an adjustment option:
  - : Brightness
  - : Contrast
  - : Saturation
- 3 Select a value. (-: less or +: more)
  - Drag left or right to preview.
- 4 Touch **OK** to save the change.

### Hiding facial imperfections

- 1 In Playback mode, select a photo and touch .
- 2 Touch  → .
- 3 Adjust a level.
  - As the number increases, the face becomes clearer.
- 4 Touch **OK** to save the change.

## Creating a print order

Define which photos are to be printed and information about the number of copies or paper size.



- The memory card can be taken to a print shop that supports DPOF (Digital Print Order Format) or you can print out photos directly through a DPOF-compatible printer at home.
- The wide photos may print with the left and right edges cut off, so check whether or not they are wide images when ordering prints.
- You cannot set a DPOF for the photos stored in the internal memory.

- 1 In Playback mode, select a photo and press **[MENU]**.
- 2 Touch **DPOF**.
- 3 Set DPOF options.

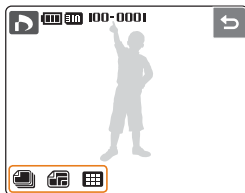

Option	Description
Images	Select a photo to be printed. <ul style="list-style-type: none"> <li>• <b>ONE</b>: print the current photo only.</li> <li>• <b>ALL</b>: print all photos in the memory card.</li> </ul>
Size	Specify the size of the print. <ul style="list-style-type: none"> <li>• <b>ONE</b>: specify the size of the current photo.</li> <li>• <b>ALL</b>: specify the size of all photos.</li> </ul>
Index*	Select whether to print the photos as thumbnails.

\* You can print multiple photos with DPOF on one sheet.



You can print specific-sized photos only with DPOF 1.1-compatible printers.

# Viewing files on a TV or HDTV

Play back photos or videos by connecting your camera to a TV using the provided A/V cable.

- 1 Select a video signal output according to your country or region. (p. 71)
- 2 Turn off your camera and TV.
- 3 Connect your camera to your TV using the A/V cable.

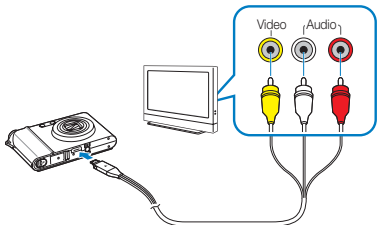

- 4 Turn on your TV and select the video output mode using the TV remote control.
- 5 Turn on your camera and press **[Playback]**.
- 6 View photos or play videos using the touch screen on your camera.



- Digital noise may occur or part of an image may not appear on some TVs.
- The images may not appear centred on the TV screen depending on your TV settings.
- You can capture a photo or video while the camera is connected to a TV.

## Viewing files on an HDTV

You can view high-quality and uncompressed photos or videos on an HDTV using the optional HDMI cradle. HDMI (High Definition Multimedia Interface) is supported by most HDTVs. For details, see the 'HDMI cradle manual'.

- 1 In Shooting or Playback mode, press **[MENU]**.
- 2 Set HDMI resolution.

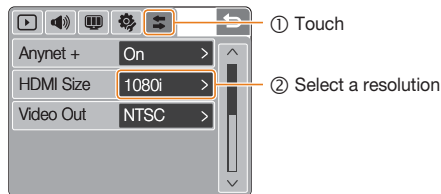

- 3 Turn off your camera and HDTV.

- 4 Insert your camera into the cradle and plug the HDMI cable into the HDTV and the cradle.



Disconnect the A/V cable if it is connected to the cradle.

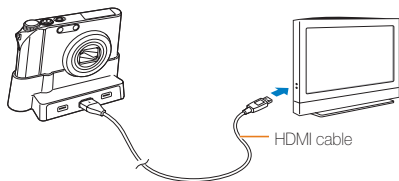

- 5 Turn on your camera.
  - The HDTV will be powered on automatically and the camera screen will be displayed.
- 6 View files using the touch screen on your camera or a remote control of your camera or HDTV.



If your HDTV supports the Anynet+(CEC) profile, turn the Anynet+ on in the settings menu (p. 71) to control all connected Samsung A/V devices with the TV remote control. For details, see the 'HDMI cradle manual'.

# Transferring files to your computer

## For Windows users

Transfer files by connecting your camera to your PC. Use the supplied USB cable after installing any programs you need from the CD.

### Installing programs

#### Hardware and software requirements

Item	Requirements
CPU	Pentium III 500MHz or better (Pentium III 800MHz or better recommended)
RAM	256 MB or more (512MB or more recommended)
OS	Windows 2000 / XP / Vista
Hard disk capacity	250MB or more (1GB or more recommended)
Others	<ul style="list-style-type: none"><li>• USB port</li><li>• CD-ROM drive</li><li>• 1024x768 pixels, 16-bit colour display compatible monitor (24-bit colour display recommended)</li><li>• Microsoft Direct X 9.0 or later</li></ul>



#### Requirements for QuickTime Player 7.4

- Intel Pentium 4, 3.2GHz or higher / AMD Athlon 64FX, 2.6GHz or higher
- Windows XP service pack2 or Vista
- Minimum 512MB RAM (1GB and above recommended)
- 64MB or greater video card (nVIDIA Geforce 7600GT or higher / ATI X1600 series or higher recommended)



- Using a self-assembled PC or a PC and OS that are not supported may void your warranty.
- For 64bit Edition of Windows XP and Vista, the programs may not work properly.

#### Programs contained on the CD

Item	Requirements
<a href="#">Samsung Master</a>	Edit photos and videos.
<a href="#">QuickTime Player 7.4</a>	View videos (MPEG-4 AVC/H.264 files) on a PC.
<a href="#">Adobe Reader</a>	View the user manual.

- 1 Insert the installation CD in a CD-ROM drive.
- 2 When the setup screen is displayed, click **Samsung Digital Camera Installer** to start installation.



- 3 Select programs to install and follow the onscreen instructions.
- 4 Click **OK** to complete the installation.

### Transferring files to your PC

Once you connect the camera to your PC, the camera will be recognised as a removable disk.



The battery will be charged while the camera is connected to a PC with the USB cable.

- 1 Connect the camera to your PC.



You must plug the end of the cable with the indicator light (▲) into your camera. If the cable is reversed, it may damage your files. The manufacturer is not responsible for any loss of data.

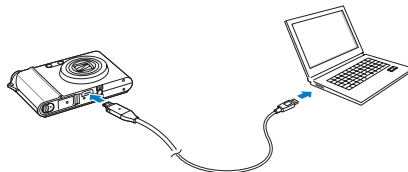

- 2 Turn on the camera.
- 3 Touch **Computer**.
- 4 On your PC, select **My Computer** → **Removable Disk** → **DCIM** → **100SSCAM**.
- 5 Select the files you want and drag or save them to your PC.

### Disconnecting the camera (for Windows XP)

The way to disconnect the USB cable for Windows 2000/Vista is similar.

- 1 Wait until your PC stops reading from the camera.
  - If the status lamp on your camera is blinking, wait until it is off.

- 2 Click  on the tool bar at the bottom right of your PC screen.



- 3 Click the pop-up message.
- 4 Remove the USB cable.

### Using Samsung Master

You can download files or edit photos or videos stored on your PC. For details, see Help in the program.



This program does not support editing of video files (H.264 (MPEG4, AVC)) on the camera.

### Downloading files using Samsung Master

A window for downloading files automatically appears when the camera is connected. Select the files you want to download. Click **Next** and follow the onscreen instructions.

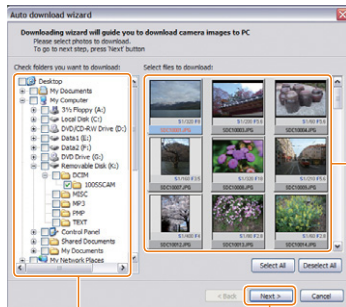

The thumbnails of files  
(Click files to download.)

Select a folder to save downloaded files

Click to download the selected files



### Using the Samsung Master Interface

#### View mode

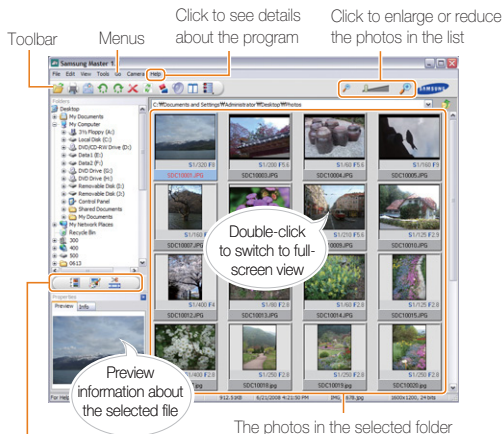

#### Change the mode

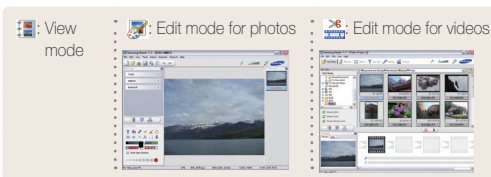

### For Mac users

Once you connect the camera to a Macintosh computer, the computer will recognise the device automatically. You can transfer files directly from the camera to the computer without installing any programs.



Mac OS X version 10.3 or more is supported.

- 1 Connect your camera to a Macintosh computer with the USB cable.
- 2 Turn on your camera.
  - The computer recognises the device automatically and a removable disk icon will be displayed.
- 3 Double-click the removable disk icon.
- 4 Transfer photos or videos to the computer.

# Printing photos with a photo printer

Print photos with a PictBridge-compatible printer by connecting your camera directly to the printer.

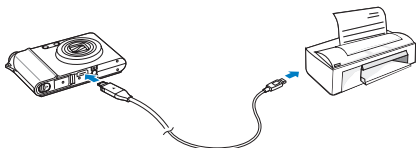

- 1 With the printer on, connect your camera with the USB cable.

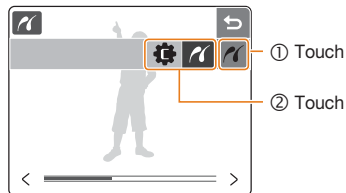

- 2 Press **[POWER]** or **[Playback]** to turn on your camera.
- 3 Touch **Printer**.

- 4 Select a print mode.











Icon	Description
	Print the current photo according to the printer's settings. (Touch  to print.)
	Print photos with custom settings. (p. 66)

**Printing with custom settings**

1 Set printing options.



- 2 Touch  to print.
- 3 Touch **Yes** to confirm.
  - Printing starts. Touch  to cancel printing.





Option	Description
 Images	Select whether to print the current photo or all photos.
 Size	Specify the size of the print.
 Layout	Create thumbnail prints.
 Type	Select the type of paper.
 Quality	Set the printing quality.
 Date	Set to print the date.
 File Name	Set to print the name of the file.



Some options are not supported by some printers.

# 5. Appendix

Refer to settings, error messages, specifications, and maintenance tips.

<b>Camera settings menu</b> .....	68
Accessing the settings menu .....	68
Sound setting  .....	69
Display setting  .....	69
Camera setting  .....	70
Connection setting  .....	71
<b>Error messages</b> .....	72
<b>Camera maintenance</b> .....	73
Cleaning your camera .....	73
About memory cards .....	74
About the battery .....	75
<b>Before contacting a service centre</b> .....	76
<b>Camera specifications</b> .....	79
<b>Index</b> .....	83

# Camera settings menu

## Accessing the settings menu

- 1 In Shooting or Playback mode, press **[MENU]**.
- 2 Select a menu.

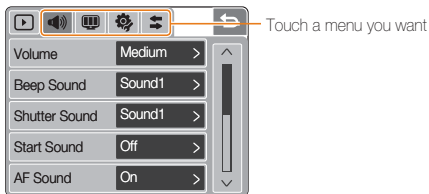

- 3 Select a menu and save your settings.

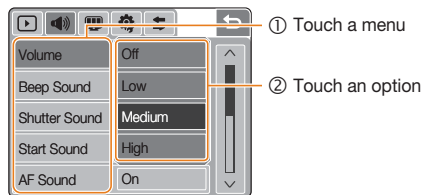

- 4 Touch **[BACK]** to return to the previous screen.

Icon	Description
	Adjust volume or set beep, shutter, start, AF or self-portrait sound. (p. 69)
	Select an onscreen language, set the date and time, set a start image, adjust the brightness of the screen, or set the duration for playing back files or display save time. (p. 69)
	Format the internal memory and memory card, reset to default setting, turn the recycle bin on, specify file names, set whether to display the shooting date or Power save time, or turn the AF assist lamp on. (p. 70)
	Set Anynet+, HDMI resolution or select a video output. (p. 71)



## Sound setting

\* Default

Item	Description
Volume	Adjust the volume of any sound. (Off, Low, Medium*, High)
Beep Sound	Select a sound to be emitted when touching the screen or switching modes. (Off, Sound1*, Sound2, Sound3)
Shutter Sound	Select a sound to be emitted when pressing the shutter button. (Off, Sound1*, Sound2, Sound3)
Start Sound	Select a sound to be emitted when turning on your camera. (Off*, Sound1, Sound2, Sound3)
AF Sound	Set to emit a sound to be emitted when half-pressing the shutter button. (Off, On*)
Self Portrait	Set to emit a sound when the camera detects your face. (Off, On*)

## Display setting

\* Default

Item	Description
Language	Select a language for the display text.
Date & Time	Select a region, set the time and date, and set the date format. (yyyy/mm/dd, mm/dd/yyyy, dd/mm/yyyy, Off*)  Select a city to set the local time when using the camera in a different country.
Start Image	Set a start image to display when the camera is switched on. <ul style="list-style-type: none"> <li>• <b>Off*</b>: Display no start image.</li> <li>• <b>LOGO</b>: Display a default image stored in the internal memory.</li> <li>• <b>User Image</b>: Display an image that the user selects. (p. 55)</li> </ul>
Display Bright	Adjust the brightness of the screen. (Auto*, Dark, Normal, Bright)  <b>Normal</b> is fixed in Playback mode even if <b>Auto</b> is selected.
Quick View	Set the duration for reviewing a captured image or video before returning to Shooting mode. (Off, 0.5 sec*, 1 sec, 3 sec)
Display Save	If you perform no operations for 30 seconds, the camera switches to Power save mode automatically (touch the screen to deactivate the Power save mode). (Off*, On)

## Camera setting



\* Default

Item	Description
Format	<p>Format the internal memory and the memory card (all files-including the protected files-will be deleted). <b>(No*, Yes)</b></p> <p> When you use a memory card use with cameras from different manufacturers or a memory card reader, or one formatted on a computer, your camera may read the card incorrectly. Format the card before using it.</p>
Reset	<p>Reset menus and shooting options (date and time, language, and video output settings will not be reset). <b>(No*, Yes)</b></p>
Recycle Bin	<p>Set the recycle bin option or restore deleted files. <b>(Off*, On, Recycle Folder)</b></p> <ul style="list-style-type: none"> <li>Select <b>Recycle Folder</b> to restore files.</li> </ul>

\* Default

Item	Description
File	<p>Specify how to name files.</p> <ul style="list-style-type: none"> <li><b>Reset:</b> Set the file number to start from 0001 when inserting a new memory card, formatting a memory card, or deleting all files.</li> <li><b>Series*:</b> Set the file number to follow the previous file number when inserting a new memory card, formatting a memory card, or deleting all files.</li> </ul> <p> • The default name of the first folder is 100SSCAM and the default name of the first file is SDC10001.</p> <ul style="list-style-type: none"> <li>The file number increases one by one from SDC10001 to SDC19999.</li> <li>The folder number increases one by one from 100SSCAM to 999SSCAM.</li> <li>The maximum number of files that can be stored in one folder is 9999.</li> <li>The camera defines file names according to the Digital rule for Camera File system (DCF) standard. If you change the names of files intentionally, the camera may not play back the files.</li> </ul>

\* Default

Item	Description
Imprint	<p>Set whether to display date and time on the photos when printing. (<b>Off*</b>, <b>Date</b>, <b>Date &amp; Time</b>)</p> <p> <ul style="list-style-type: none"> <li>The date and time will be displayed on the bottom-right corner of the photo in yellow.</li> <li>The date and time may not be printed on some printer models.</li> <li>If you select <b>T</b> in the <b>SCENE</b> mode, the date and time will not be displayed.</li> </ul> </p>
Power Off	<p>Turn off your device when not being used. (<b>Off</b>, <b>1 min</b>, <b>3 min*</b>, <b>5 min</b>, <b>10 min</b>)</p> <p> <ul style="list-style-type: none"> <li>Your settings will not change after changing the battery.</li> <li>This will not function when: <ul style="list-style-type: none"> <li>- the camera is connected to a computer or printer</li> <li>- you play a slide show or videos</li> <li>- you record a voice memo</li> </ul> </li> </ul> </p>
AF Lamp	<p>Set an assistant light to help you focus in the dark. (<b>Off</b>, <b>On*</b>)</p>

## Connection setting

\* Default

Item	Description
Anynet+	<p>Set to control the camera connected to a Samsung HDTV that supports Anynet+(CEC) with the TV remote control.</p> <ul style="list-style-type: none"> <li><b>Off</b>: View files without using an HDTV remote control.</li> <li><b>On*</b>: Control the camera with an HDTV remote control.</li> </ul>
HDMI Size	<p>Select the resolution of photos when playing back files on an HDTV with the HDMI cradle. (NTSC: <b>1080i*</b>, <b>720p</b>, <b>480p</b> / PAL: <b>1080i*</b>, <b>720p</b>, <b>576p</b>)</p> <p> If the HDTV does not support the selected resolution, the HDTV automatically selects the next lower resolution.</p>
Video Out	<p>Set the video signal output according to your region.</p> <ul style="list-style-type: none"> <li><b>NTSC*</b>: USA, Canada, Japan, Korea, Taiwan, Mexico, etc.</li> <li><b>PAL</b> (supports only BDGHI): Australia, Austria, Belgium, China, Denmark, Finland, Germany, England, Italy, Kuwait, Malaysia, New Zealand, Singapore, Spain, Sweden, Switzerland, Thailand, Norway, etc.</li> </ul>



## Error messages

When the following error messages appear, try these remedies.

Error message	Suggested remedies
<b>Card Error!</b>	<ul style="list-style-type: none"><li>• Turn off your camera and turn it on again.</li><li>• Remove your memory card and insert it again.</li><li>• Format your memory card. (p. 70)</li></ul>
<b>Low Battery!</b>	Insert a charged battery or recharge the battery.
<b>No Image!</b>	Take photos or insert a memory card that has some photos.
<b>Low Light!</b>	Turn the flash on. (p. 33)
<b>File Error!</b>	Delete the damaged file or contact a service centre.
<b>Memory Full!</b>	Delete unnecessary files or insert a new memory card.

Error message	Suggested remedies
<b>Card Locked!</b>	Unlock the memory card. 
<b>DCF Full Error</b>	File names do not match the DCF standard. Transfer the files on the memory card to your computer and format the card. (p. 70)

# Camera maintenance

## Cleaning your camera

### Camera lens and touch screen

Use a blower brush to remove dust and wipe the lens gently with a soft cloth. If any dust remains, apply lens cleaning liquid to a piece of cleaning paper and wipe gently.

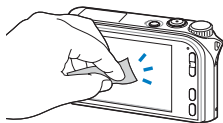
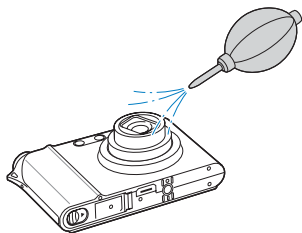

### Camera body

Wipe gently with a soft, dry cloth.

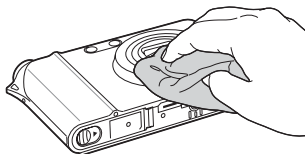

- Never use benzene, thinners, or alcohol to clean the device. These may cause damage or malfunctions.
- Do not press on the lens cover or use a blower brush on the cover.

## About memory cards

### Memory cards you can use

You can use SD (Secure Digital), SDHC (Secure Digital High Capacity), or MMC (MultiMedia Card) memory cards.

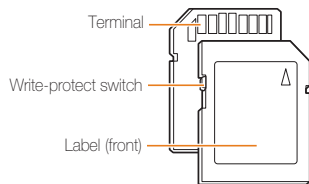

You can prevent files from being deleted by using a write-protect switch on the SD or SDHC card. Slide the switch down to lock or slide it up to unlock. Unlock the card when shooting.

### Memory card capacity

The memory capacity may differ depending on shooting scenes or shooting conditions. For 1GB SD card:

	Size	Super fine	Fine	Normal	60FPS	30FPS	15FPS
P h o t o s	<b>14m</b>	136	265	386	-	-	-
	<b>13m</b>	153	296	430	-	-	-
	<b>10m</b>	180	347	501	-	-	-
	<b>8m</b>	240	457	653	-	-	-
	<b>5m</b>	370	685	957	-	-	-
	<b>2m</b>	807	1374	1794	-	-	-
* V i d e o s	<b>1m</b>	1655	2438	2894	-	-	-
	<b>1280 HD</b>	-	-	-	-	Approx. 12' 38"	Approx. 20min
	<b>1280</b>	-	-	-	-	Approx. 20min	Approx. 20min
	<b>640</b>	-	-	-	-	Approx. 20min	Approx. 20min
	<b>320</b>	-	-	-	Approx. 20min	Approx. 20min	Approx. 20min

\* The recordable time may vary if you use the zoom.

## About the battery

Use only Samsung-approved batteries.

### Battery specifications

Mode	SLB-1137D
Type	Lithium-ion battery
Cell capacity	1100mAh
Voltage	3.7V
Charging time (when the camera is switched off)	Approx. 150min

### Battery life

Shooting time / Number of photos		Shooting conditions (when the battery is fully charged)
Photos	Approx. 100min/ Approx. 200	<p>This is measured under the following conditions: in the <b>AUTO</b> mode, 14M resolution, Fine quality, OIS on.</p> <ol style="list-style-type: none"> <li>1. Set the flash option to <b>Fill in</b>, take a single shot, and zoom in or out.</li> <li>2. Set the flash option to <b>Off</b>, take a single shot, and zoom in or out.</li> <li>3. Perform steps 1 and 2 for 30 seconds and repeat for 5 minutes. Then turn off the camera for 1 minute.</li> <li>4. Repeat steps 1 to 3.</li> </ol>

Shooting time / Number of photos		Shooting conditions (when the battery is fully charged)
Videos	Approx. 90min	Record videos at 640x480 resolution and 30fps.

- The figures above are measured by Samsung's standards and may differ depending on usage.
- Several videos were recorded in succession to determine the total recording time.

### Notes about charging the battery

- If the indicator light is off, make sure that the battery is inserted correctly.
- Turn off your camera when charging.
- Turn on your camera after charging the battery for more than 10 minutes.
- Using flash or recording videos depletes the battery quickly. Charge the battery until the indicator light turns green.
- If the indicator light blinks in red or does not illuminate, reconnect the cable, or remove the battery and insert it again.
- If you charge the battery when it is warm, the indicator light may turn orange. Charging will start when the battery cools down.



### Notes about charging with a computer connected

- Use only the provided USB cable.
- The battery may not be charged when:
  - you use a USB hub
  - other USB devices are connected to your computer
  - you connect the cable to the port on the front side of your computer
  - the USB port of your computer does not support the Power output standard (5V, 500mA)

## Before contacting a service centre

If you are having trouble with your camera, try these troubleshooting procedures before contacting a service centre. If you have attempted the troubleshooting solution and are still having problems with your device, contact your local dealer or service centre.

Situation	Suggested remedies
Cannot turn on the camera	<ul style="list-style-type: none"><li>• Make sure the a battery is inserted.</li><li>• Make sure the battery is inserted correctly.</li><li>• Charge the battery.</li></ul>
The power turns off suddenly	<ul style="list-style-type: none"><li>• Charge the battery.</li><li>• Your camera may be in Power save mode. (p. 69)</li><li>• The camera may turn off to prevent the memory card from being damaged due to an impact. Turn on your camera again.</li></ul>
The camera is losing battery power quickly	<ul style="list-style-type: none"><li>• The battery may lose power more quickly in low temperatures (below 0°C). Keep the battery warm by putting it into your pocket.</li><li>• Using the flash or recording videos depletes the battery quickly. Recharge if needed.</li><li>• Batteries are consumable parts that must be replaced over time. Get a new battery if the battery life is diminishing quickly.</li></ul>

Situation	Suggested remedies
Cannot take photos	<ul style="list-style-type: none"><li>• There is no space on the memory card. Delete unnecessary files or insert a new card.</li><li>• Format the memory card. (p. 70)</li><li>• The memory card is defective. Get a new memory card.</li><li>• The memory card is locked. Unlock the card. (p. 72)</li><li>• Make sure the camera is switched on.</li><li>• Charge the battery.</li><li>• Make sure the battery is inserted correctly.</li></ul>
The camera freezes	Remove the battery and insert it again.
The flash does not work	<ul style="list-style-type: none"><li>• The flash option may be set to <b>Off</b>. (p. 33)</li><li>• You cannot use the flash in the  <b>DUAL</b>,  or some <b>SCENE</b> modes.</li></ul>
The camera fires the flash suddenly	The flash may fire due to static electricity. This is not a malfunction of the camera.

Situation	Suggested remedies
<b>The date and time are incorrect</b>	Set the date and time in the display settings menu.
<b>The touch screen or buttons do not work</b>	Remove the battery and insert it again.
<b>The memory card has an error</b>	The memory card has not been reset. Format the card. (p. 70)
<b>Cannot play back files</b>	If you change the name of a file, your camera may not play the file (the name of the file should meet the DCF standard). If you encounter this situation, play back files on your computer.
<b>The photo is blurry</b>	<ul style="list-style-type: none"> <li>• Make sure the focus option you set is suitable for close-up shots. (p. 36)</li> <li>• Make sure that the subject is within range of the flash. (p. 79)</li> <li>• Make sure the camera lens is clean. If not, clean the lens. (p. 73)</li> </ul>
<b>The colours in the photo do not match the actual scene</b>	An incorrect white balance can create unrealistic colour. Select the proper white balance option to suit the light source. (p. 42)

Situation	Suggested remedies
<b>The photo is too bright</b>	<ul style="list-style-type: none"> <li>• Your photo is overexposed. Adjust the exposure value. (p. 40)</li> <li>• Turn the flash off. (p. 33)</li> </ul>
<b>The TV does not display your photos</b>	<ul style="list-style-type: none"> <li>• Make sure the camera is correctly connected to the external monitor with the A/V cable.</li> <li>• Make sure your memory card contains photos.</li> </ul>
<b>Your computer does not recognise your camera</b>	<ul style="list-style-type: none"> <li>• Make sure the USB cable is connected correctly.</li> <li>• Make sure your camera is switched on.</li> <li>• Make sure you are using a supported operating system.</li> </ul>
<b>Your computer disconnects the camera while transferring files</b>	The file transmission may be interrupted by static electricity. Disconnect the USB cable and connect it again.

Situation	Suggested remedies
Your computer cannot play videos	<p>The codec installed in your computer may not be compatible with the video files you want to play. Use QuickTime® Player or install Codec Pack Full.</p> <ul style="list-style-type: none"><li>• <b>Using QuickTime® Player 7.4</b><ol style="list-style-type: none"><li>1. Install QuickTime® Player 7.4 which supports MP4 (H.264 (MPEG.AVC)).</li><li>2. Play videos using QuickTime® Player.</li></ol></li><li>• <b>Using Codec Pack Full</b><ol style="list-style-type: none"><li>1. Install the latest version of Codec Pack Full.</li><li>2. Play videos using the media player (Media Player Classic or Windows Media Player 11 recommended).</li></ol></li></ul> <p> • Install QuickTime® Player 7.4 or K-Lite Codec Pack Full on Windows XP SP2 or later.</p> <ul style="list-style-type: none"><li>• Depending on your computer environment, the video playback may be intermittent.</li></ul>





















# Camera specifications

<b>Image sensor</b>	Type	1/1.72" (1.49 cm) CCD		
	Effective pixels	Approx. 14.7 mega-pixels		
	Total pixels	Approx. 15.0 mega-pixels		
<b>Lens</b>	Focal length	Schneider - KREUZNACH lens f = 6.0 - 21.6 mm (35 mm film equivalent: 28 - 102 mm)		
	F-stop range	F2.8 (W) - F5.9 (T)		
	Digital zoom	<ul style="list-style-type: none"> <li>• Still Image mode: 1.0X - 5.0X</li> <li>• Play mode: 1.0X - 13.7X (depending on image size)</li> </ul>		
<b>LCD monitor</b>		3.0" (7.62 cm) hVGA colour TFT LCD (460,000 pixels) (Touch)		
<b>Focusing</b>	Type	TTL auto focus (Multi AF, Center AF, Touch AF, Face Detection AF)		
	Range		Wide (W)	Tele (T)
		Normal	80 cm - infinity	
		Macro	5 cm - 80 cm	50 cm - 80 cm
		Auto macro	5 cm - infinity	50 cm - infinity
<b>Shutter speed</b>		<ul style="list-style-type: none"> <li>• AUTO: 1 - 1/2,000 sec.</li> <li>• MANUAL: 16 - 1/2,000 sec.</li> <li>• NIGHT: 8 - 1/2,000 sec.</li> <li>• FIREWORK: 4 sec.</li> </ul>		

<b>Exposure</b>	Control	Program AE
	Metering	Multi, Spot, Center Weighted, Face Detection AE
	Compensation	±2EV (1/3EV steps)
	ISO Equivalent	Auto, 80, 100, 200, 400, 800, 1600, 3200 (Photo size of 3200 is fixed as 3M)
<b>Flash</b>	Mode	Off, Auto, Red Eye, Fill in, Slow Sync, Red Eye Fix
	Range	Wide: 0.3 m - 5.4 m (ISO Auto) Tele: 0.5 m - 2.7 m (ISO Auto)
	Recharging time	Approx. 5 sec.
<b>Shake reduction</b>		Dual IS [Optical Image Stabilisation (OIS) + Digital Image Stabilisation (DIS)]
<b>Sharpness</b>		Soft+, Soft, Normal, Vivid, Vivid+
<b>Effect</b>	Shooting mode	<ul style="list-style-type: none"> <li>• Photo Style Selector: Normal, Soft, Vivid, Forest, Retro, Cool, Calm, Classic</li> <li>• Color: Normal, B &amp; W, Sepia, Blue, Red, Green, Negative</li> <li>• Image adjust: Sharpness, Contrast, Saturation</li> </ul>
	Playback mode	<ul style="list-style-type: none"> <li>• Image edit: Resize, Rotate, Trimming</li> <li>• Color effect: Normal, B &amp; W, Sepia, Blue, Red, Green, Negative</li> <li>• Special color: Color Filter, Shaded, Elegant, Add Noise</li> <li>• Image adjust: Face retouch, Brightness, Contrast, Saturation, Red Eye Fix, ACB</li> </ul>



<b>White Balance</b>	Auto WB, Daylight, Cloudy, Fluorescent_H, Fluorescent_L, Tungsten, Custom Set
<b>Voice recording</b>	Voice Recording (Max 10 hours) Voice Memo in Still Image (Max. 10 sec.)
<b>Date Imprinting</b>	Date & Time, Date, Off (user selectable)
<b>Shooting</b>	Photos <ul style="list-style-type: none"> <li>Modes: AUTO, PROGRAM, MANUAL, DUAL IS, NIGHT, BEAUTY SHOT, SCENE (PORTRAIT, CHILDREN, LANDSCAPE, CLOSE UP, TEXT, SUNSET, DAWN, BACKLIGHT, FIREWORK, BEACH &amp; SNOW, SELF SHOT, FOOD, CAFE)</li> <li>Continuous: Single, Continuous, High Speed, M. Capture, AEB</li> <li>Timer: 10 sec, 2 sec, Double, Remote</li> </ul>
	Videos <ul style="list-style-type: none"> <li>With Audio or without Audio (Max Recording time: 20 min)</li> <li>Size: 1280 x 720 (30FPS, 15FPS) High Quality, 1280 x 720 (30FPS, 15FPS) Standard Quality, 640 x 480 (30FPS, 15FPS), 320 x 240 (60FPS, 30FPS)</li> <li>Frame rate: 60 FPS, 30 FPS, 15 FPS</li> <li>3.6X Optical Zoom and Mute in Zooming (sound is muted when operating the zoom function)</li> <li>Color Effect &amp; WB selectable</li> <li>Video Editing (embedded): Pause during recording, Still Image Capture, Time Trimming</li> </ul> Due to the noise while optical zooming, user can select to record sound or not.

<b>Storage</b>	Media	<ul style="list-style-type: none"> <li>Internal memory: approx. 40MB</li> <li>External memory (Optional)                             <ul style="list-style-type: none"> <li>SD card (up to 4GB guaranteed)</li> <li>SDHC card (up to 8GB guaranteed)</li> <li>MMC Plus (up to 2GB guaranteed, 4bit 20MHz)</li> </ul> </li> </ul> Internal memory capacity may not match these specifications.																																						
	File format	<ul style="list-style-type: none"> <li>Still image: JPEG (DCF), EXIF 2.21, DPOF 1.1, PictBridge 1.0</li> <li>Video: MP4 (H.264(MPEG4.AVC))</li> <li>Audio: WAV</li> </ul>																																						
	Image size	For 1GB SD <table border="1"> <thead> <tr> <th></th> <th>Super fine</th> <th>Fine</th> <th>Normal</th> </tr> </thead> <tbody> <tr> <td> 14M</td> <td>4384x3288</td> <td>136</td> <td>265</td> <td>386</td> </tr> <tr> <td> 13M</td> <td>4384x2920</td> <td>153</td> <td>296</td> <td>430</td> </tr> <tr> <td> 10M</td> <td>4384x2464</td> <td>180</td> <td>347</td> <td>501</td> </tr> <tr> <td> 8M</td> <td>3264x2448</td> <td>240</td> <td>457</td> <td>653</td> </tr> <tr> <td> 5M</td> <td>2592x1944</td> <td>370</td> <td>685</td> <td>957</td> </tr> <tr> <td> 2.5M</td> <td>1920x1080</td> <td>807</td> <td>1374</td> <td>1794</td> </tr> <tr> <td> 1M</td> <td>1024x768</td> <td>1655</td> <td>2438</td> <td>2894</td> </tr> </tbody> </table> <p>These figures are measured under Samsung's standard conditions and may vary depending on shooting conditions and camera settings.</p>		Super fine	Fine	Normal	 14M	4384x3288	136	265	386	 13M	4384x2920	153	296	430	 10M	4384x2464	180	347	501	 8M	3264x2448	240	457	653	 5M	2592x1944	370	685	957	 2.5M	1920x1080	807	1374	1794	 1M	1024x768	1655	2438
	Super fine	Fine	Normal																																					
 14M	4384x3288	136	265	386																																				
 13M	4384x2920	153	296	430																																				
 10M	4384x2464	180	347	501																																				
 8M	3264x2448	240	457	653																																				
 5M	2592x1944	370	685	957																																				
 2.5M	1920x1080	807	1374	1794																																				
 1M	1024x768	1655	2438	2894																																				
<b>Image Play</b>	Single image, Thumbnails, Advanced slide show (with effect and music)																																							

## Camera specifications

---

<b>Interface</b>	Digital output	Connector: USB 2.0 (30 pin)
	Audio output	Mono (Internal speaker), Stereo (Microphone)
	Video output	<ul style="list-style-type: none"> <li>• AV: NTSC, PAL (selectable)</li> <li>• HDMI 1.2: NTSC, PAL (selectable)</li> </ul> HDMI is available when it is connected to the optional cradle.
	DC power input connector	30 pin, 4.2V
<b>Power source</b>	Rechargeable battery	Lithium-ion battery SLB-1137D (1100mAh)
	AC adapter	Power adapter (SAC-47), USB cable (SUC-C4)
	Cradle (Optional)	SCC-NV5 HD
	The power source may differ depending on your region.	
<b>Dimensions (W x H x D)</b>		94.9 x 59.5 x 19.9 mm (without projection part)
<b>Weight</b>		138g (without battery and memory card)
<b>Operating temperature</b>		0 - 40°C
<b>Operating humidity</b>		5 - 85%
<b>Software</b>		Samsung Master, QuickTime® Player 7.4, Adobe Reader

Specifications are subject to change without prior notice.



### Correct Disposal of This Product (Waste Electrical & Electronic Equipment)

(Applicable in the European Union and other European countries with separate collection systems)

This marking shown on the product or its literature, indicates that it should not be disposed with other household wastes at the end of its working life. To prevent possible harm to the environment or human health from uncontrolled waste disposal, please separate this from other types of wastes and recycle it responsibly to promote the sustainable reuse of material resources. Household users should contact either the retailer where they purchased this product, or their local government office, for details of where and how they can take this item for environmentally safe recycling. Business users should contact their supplier and check the terms and conditions of the purchase contract. This product should not be mixed with other commercial wastes for disposal.



### Correct disposal of batteries in this product

(Applicable in the European Union and other European countries with separate battery return systems.)

This marking on the battery, manual or packaging indicates that the batteries in this product should not be disposed of with other household waste at the end of their working life. Where marked, the chemical symbols Hg, Cd or Pb indicate that the battery contains mercury, cadmium or lead above the reference levels in EC Directive 2006/66. If batteries are not properly disposed of, these substances can cause harm to human health or the environment.

To protect natural resources and to promote material reuse, please separate batteries from other types of waste and recycle them through your local, free battery return system.

The rechargeable battery incorporated in this product is not user replaceable. For information on its replacement, please contact your service provider.



### Samsung Eco-mark

It is Samsung's own symbol mark is used to effectively communicate Samsung's environmental friendly product activities to the consumers. The mark represents Samsung's continuous effort on development of environmental conscious products.

# Index

---

## A

ACB 41, 57

### Adjusting

Brightness 57

Contrast

in Playback mode 57

in Shooting mode 46

Saturation

in Playback mode 57

in Shooting mode 46

Sharpness 46

Adobe Reader 61

AF-assist light 11

AF Lamp 71

AF Sound 69

Anyet+ 71

Aperture value 23

Auto Contrast Balance  
(ACB) 41, 57

Auto mode 20

## B

### Battery

Charging 75

Life 75

Specifications 75

Beauty Shot mode 21

Blink Detection 39

### Burst

Auto Exposure Bracket  
(AEB) 44

High Speed 44

Motion Capture 44

## C

Camera shake 26

Capturing an image 53

### Cleaning

Body 73

Display 73

Lens 73

Colour effects 45

Colour tone 56

Cropping 53

## D

Date & Time 69

Deleting files 50

Digital Image Stabilisation 21

Digital zoom 18

Disconnecting the device 63

Display bright 69

DPOF 58

Dragging 15

Dual IS mode 21

## E

Editing 55

Enlarging 52

Error messages 72

Exposure 40

## F

Face Detection 38

### Filter

Add noise 56

Colour filter 56

Elegant 56

Shaded 56

### Flash

Auto 33

Fill in 33

Off 33

Red Eye 33

Red Eye Fix 34

Slow Sync 34

Flash unit 11

### Focus area

Center AF 37

Multi AF 37

Touch AF 37

### Focus distance

Auto Macro 36

Macro 36

Normal (AF) 36

Format 70

Frame rate 24

## H

HDTV 59

## I

Icons 13

Image Restoration 70

Imprint 71

ISO speed 35

## L

Light source  
(White balance) 42

## M

Maintenance 73

Manual mode 22

Memory card

Capacity 74

MMC 74

SD 74

SDHC 74

Menu button 12

Metering

Center 42

Multi 42

Spot 42

Mode dial 11

Muting

Camera 14

Video 24

## N

Night mode 20

## O

Optical Image Stabilisation  
(OIS) 18, 21

## P

Photo quality 31

Photo styles 45

Playback button 12, 14

Playback mode 48

Printing photos

Date 66

File name 66

Images 66

Layout 66

Quality 66

Size 66

Type 66

Print order

Index 58

Size 58

Program mode 22

Protecting files 50

## Q

QuickTime Player 61

Quick View 69

## R

Recording

Video 24

Voice memo 28

Recycle bin 51

Red-eye 33

Remote control 32

Remote control sensor 11

Resizing 55

Resolution

Photo 30

Video 30

Rotating 55

## S

### Samsung Master

Installing 61

Using 63

Scene mode 20

Self Portrait 39

Service centre 76

Shutter button 11

Shutter speed 22

Slide show 52

Smile Shot 39

Start image 69

## T

Timer 32

Timer lamp 11

Touching 15

Touch screen 12

### Transferring files

for Mac 64

for Windows 61

Tripod mount 12

## U

USB and A/V port 12

## V

### Video

Playing 53

Recording 24

Video Out 71

### Viewing files

as thumbnails 49

by date 49

on TV 59

### Voice memo

Playing 54

Recording 28

Volume 69

## W

White Balance 42

## Z

Zooming 17

Zoom T/Expand button 12

Zoom W/Thumbnail  
button 12



Please refer to the warranty that came with your product or go to our website <http://www.samsungcamera.com/> for after-sales service or inquiries.



The CE Mark is a Directive conformity mark of the European Community (EC)