

# Canon

## DIGITAL VIDEO CAMCORDER Instruction Manual

English

# XL2

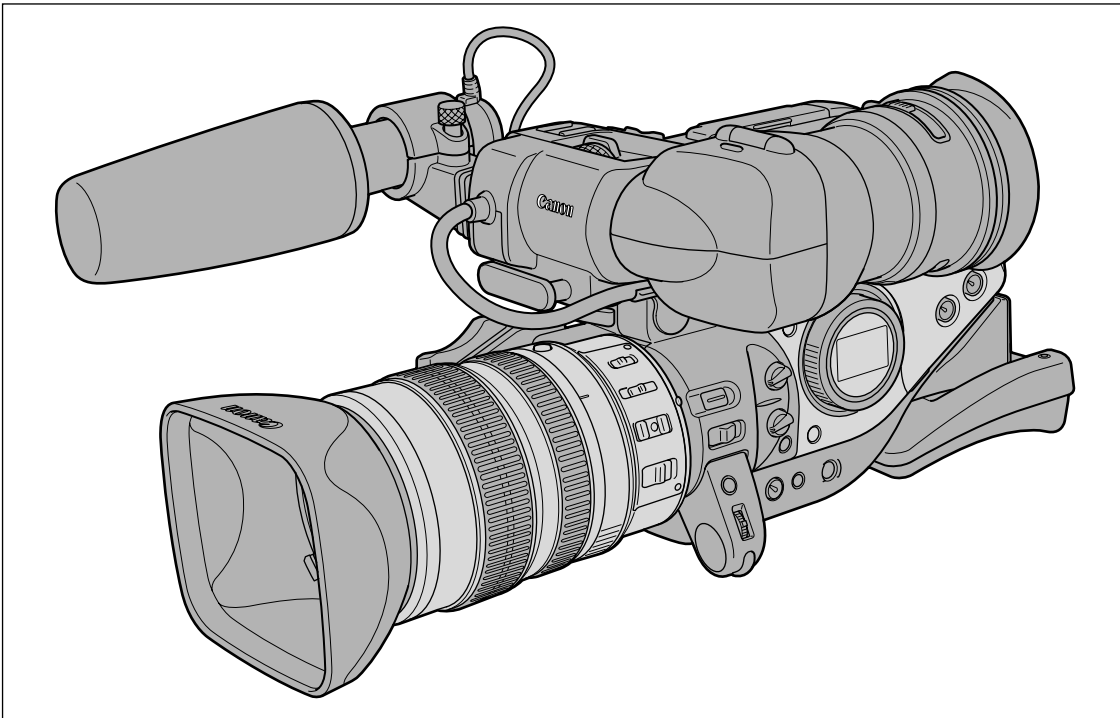

Introduction

Preparation

Recording

Playback

Editing

Additional  
Information

Mini **DV** Digital  
Video  
Cassette

**PAL**

# Important Usage Instructions

---

**WARNING:**



TO REDUCE THE RISK OF ELECTRIC SHOCK, DO NOT REMOVE COVER (OR BACK). NO USER SERVICEABLE PARTS INSIDE. REFER SERVICING TO QUALIFIED SERVICE PERSONNEL.

**WARNING:**



TO REDUCE THE RISK OF FIRE OR ELECTRIC SHOCK, DO NOT EXPOSE THIS PRODUCT TO RAIN OR MOISTURE.

**CAUTION:**

TO REDUCE THE RISK OF ELECTRIC SHOCK AND TO REDUCE ANNOYING INTERFERENCE, USE THE RECOMMENDED ACCESSORIES ONLY.

**CAUTION:**

DISCONNECT THE MAINS PLUG FROM THE SUPPLY SOCKET WHEN NOT IN USE.

**For Users in the UK**

When replacing the fuse only a correctly rated approved type should be used and be sure to re-fit the fuse cover.



CA-920 identification plate is located on the bottom.

- Use of CV-150F/CV-250F DV cable is necessary to comply with the technical requirement of EMC Directive.

# Using this Manual

Thank you for purchasing the Canon XL2. Please read this manual carefully before you use the camcorder and retain it for future reference.

## Symbols and References Used in This Manual

-  : Precautions related to the camcorder operation.
-  : Additional topics that complement the basic operating procedures.
-  : Reference page number.
- Capital letters are used to refer to buttons on the camcorder or the wireless controller.
- [ ] are used to refer to menu items displayed on the screen.
- The supplied 20× L IS Zoom Lens XL 5.4-108 mm is referred to as “20× L IS Lens”.
- The illustrations show the camcorder attached with the 20× L IS Lens.

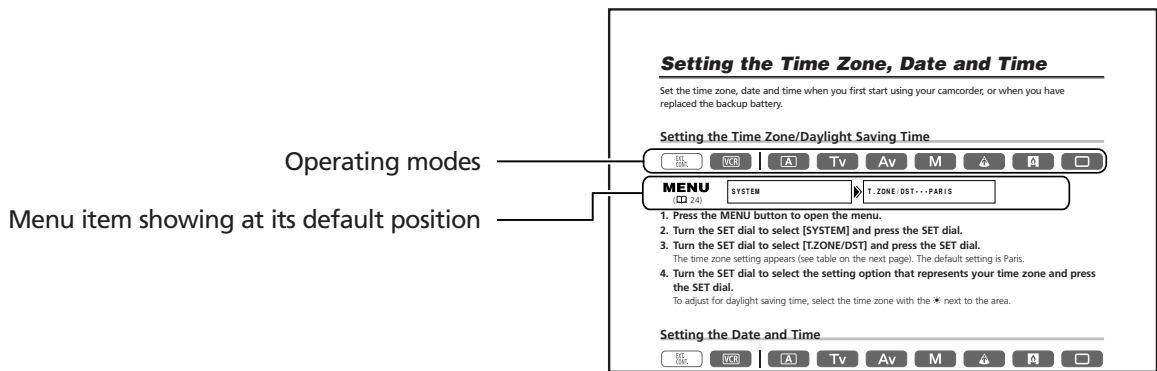

- Available functions depend on the operating mode and are indicated as follows:





: Function can be used in this mode.



: Function cannot be used in this mode.

## Trademark Acknowledgements

- Canon is a registered trademarks of Canon Inc.
- Mini  is a trademark.
-  is a trademark.
- Windows® is either a registered trademark or trademark of Microsoft Corporation in the United States and/or other countries.
- Other names and products not mentioned above may be registered trademarks or trademarks of their respective companies.

# Contents

---

## Introduction

---

Important Usage Instructions .....	2
Using this Manual .....	3
Checking Supplied Accessories .....	6
Components Guide .....	7

## Preparation

---

Preparing the Power Supply .....	11
Installing the Backup Battery .....	14
Preparing the Camcorder .....	15
Preparing the Lens.....	20
Using the Wireless Controller .....	22
Loading/Unloading a Cassette .....	23
Menus and Settings.....	24
Setting the Time Zone, Date and Time .....	28

## Recording

---

Recording .....	30
End Search .....	35
Zooming .....	36
Adjusting the Focus .....	38
Using the ND Filter (Lenses with Built-in ND Filter) .....	41
Selecting the Frame Rate .....	42
Recording in 16:9 Mode .....	43
Setting the Time Code.....	44
Setting the User Bit .....	45
Audio Recording .....	46
Image Stabilizer (Lenses Equipped with Image Stabilizer).....	50
Using the Programmed AE Modes .....	51
Recording in the Shutter-Priority (Tv) Mode .....	54
Recording in the Aperture-Priority (Av) Mode .....	55
Recording in the Manual Mode .....	56
Adjusting the Exposure .....	57
Using AE Shift .....	58
Adjusting the Gain .....	59
Setting the White Balance .....	60
Using the Zebra Pattern .....	62
Using the Skin Detail Function .....	63
Using the Custom Preset .....	64
Using Clear Scan for Recording Computer Screens.....	69
Using the Custom Keys .....	70
Recording Colour Bars/Audio Reference Signal .....	73
Recording with the Interval Timer .....	75
Recording with the Self-Timer .....	77
Using the DV Control .....	78
Other Camcorder Functions/Settings .....	79

## Playback

---

Playing Back a Tape .....	81
Playing Back on a TV Screen .....	83
Audio Output.....	86
Returning to a Pre-Marked Position .....	87
Index Search .....	88
Date Search .....	89
Displaying the Data Code .....	90
Changing the Remote Sensor Mode .....	92

## Editing

---



Recording to a VCR or Digital Video Device .....	93
Recording from Analog Video Devices (VCR, TV or Camcorder) .....	94
Recording from Digital Video Devices (DV Dubbing) .....	95
Converting Analog Signals into Digital Signals (Analog-Digital Converter) .....	97
Connecting to a Computer Using a DV (IEEE1394) Cable.....	99

## Additional Information

---

Settings Retained at Power Off or STANDBY Mode .....	100
Screen Displays.....	102
List of Messages .....	105
Maintenance/Others .....	106
Troubleshooting.....	111
System Diagram .....	113
Optional Accessories .....	114
Specifications .....	117
Index .....	119
Audio Block Diagram .....	120

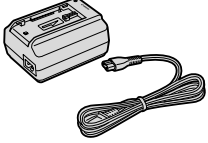
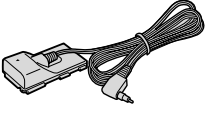
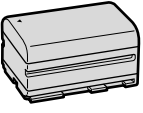
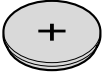
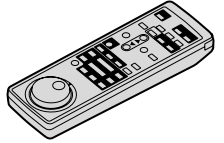
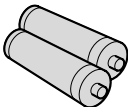
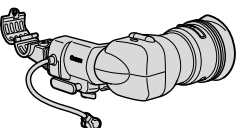
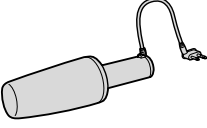
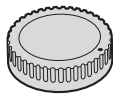
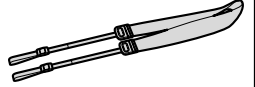
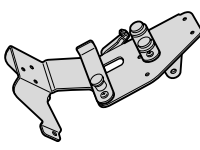
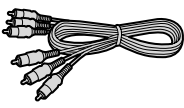
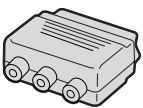
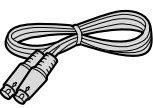
# Checking Supplied Accessories

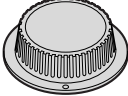
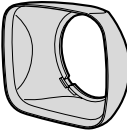
<p>CA-920 Compact Power Adapter</p> 	<p>DC-920 DC Coupler</p> 	<p>BP-930 Battery Pack</p> 	<p>Lithium Button Battery CR2025</p> 	<p>WL-D4000 Wireless Controller</p> 
<p>Two AAA (R03) Batteries</p> 	<p>Colour Viewfinder</p> 	<p>Microphone Unit</p> 	<p>Camcorder Dust Cap</p> 	<p>SS-1000 Shoulder Strap</p> 
<p>Adapter Holder</p> 	<p>STV-150 Stereo Video Cable</p> 	<p>PC-A10 SCART Aapter*</p> 	<p>S-150 S-video Cable</p> 	<p>20× L IS Zoom Lens XL 5.4-108 mm (with soft case)</p> 
<p>Lens Cap</p> 	<p>Lens Dust Cap</p> 	<p>Lens Hood</p> 		

\* Not supplied in Oceania and China.

# Components Guide

## XL2

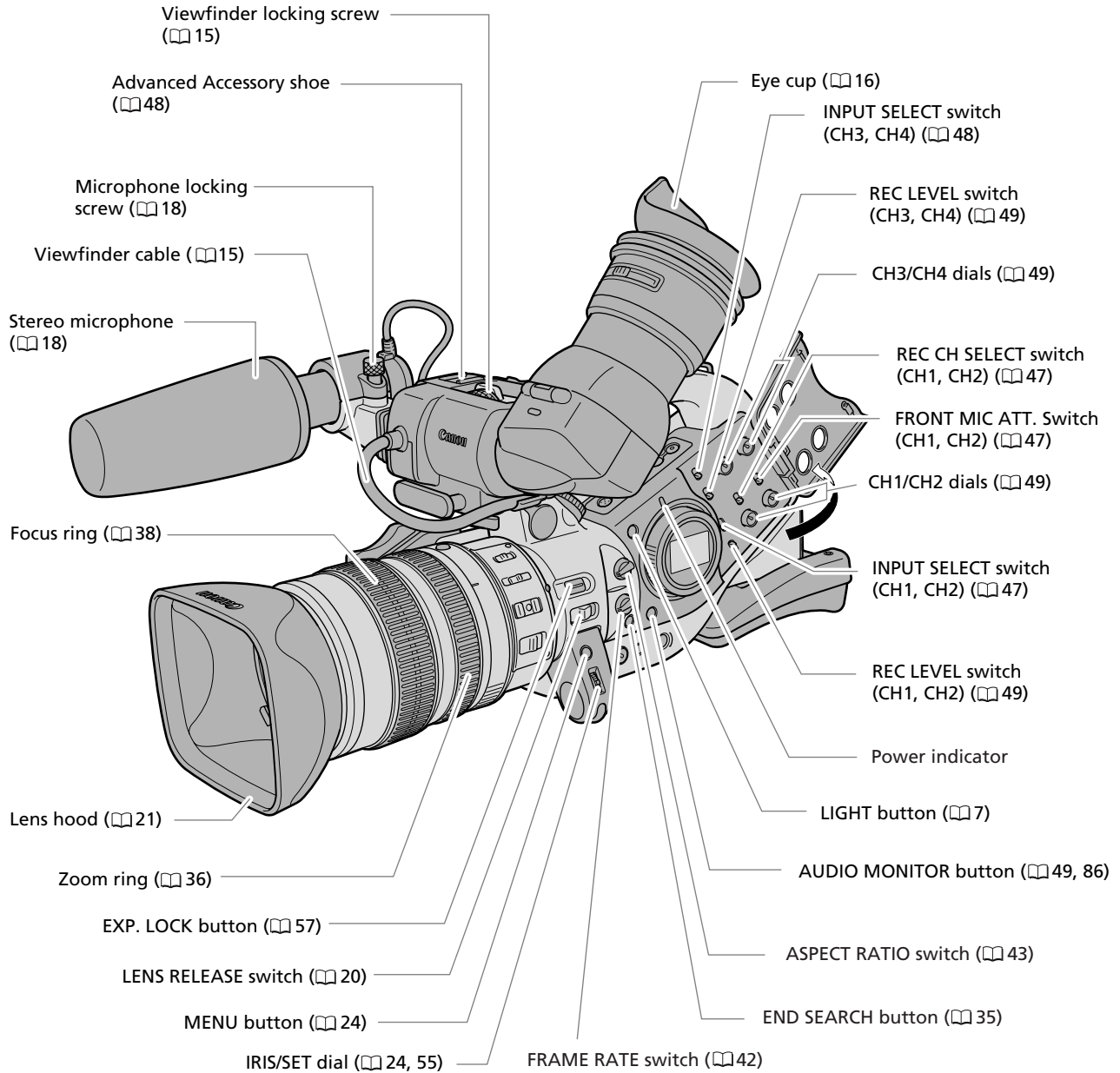

### LIGHT Button

Press the LIGHT button to illuminate the side panel for approximately 10 seconds. If you press and hold the button for at least 3 seconds, the panel remains illuminated until you press the button once more to turn the backlight off.

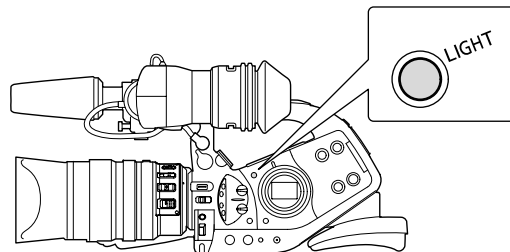

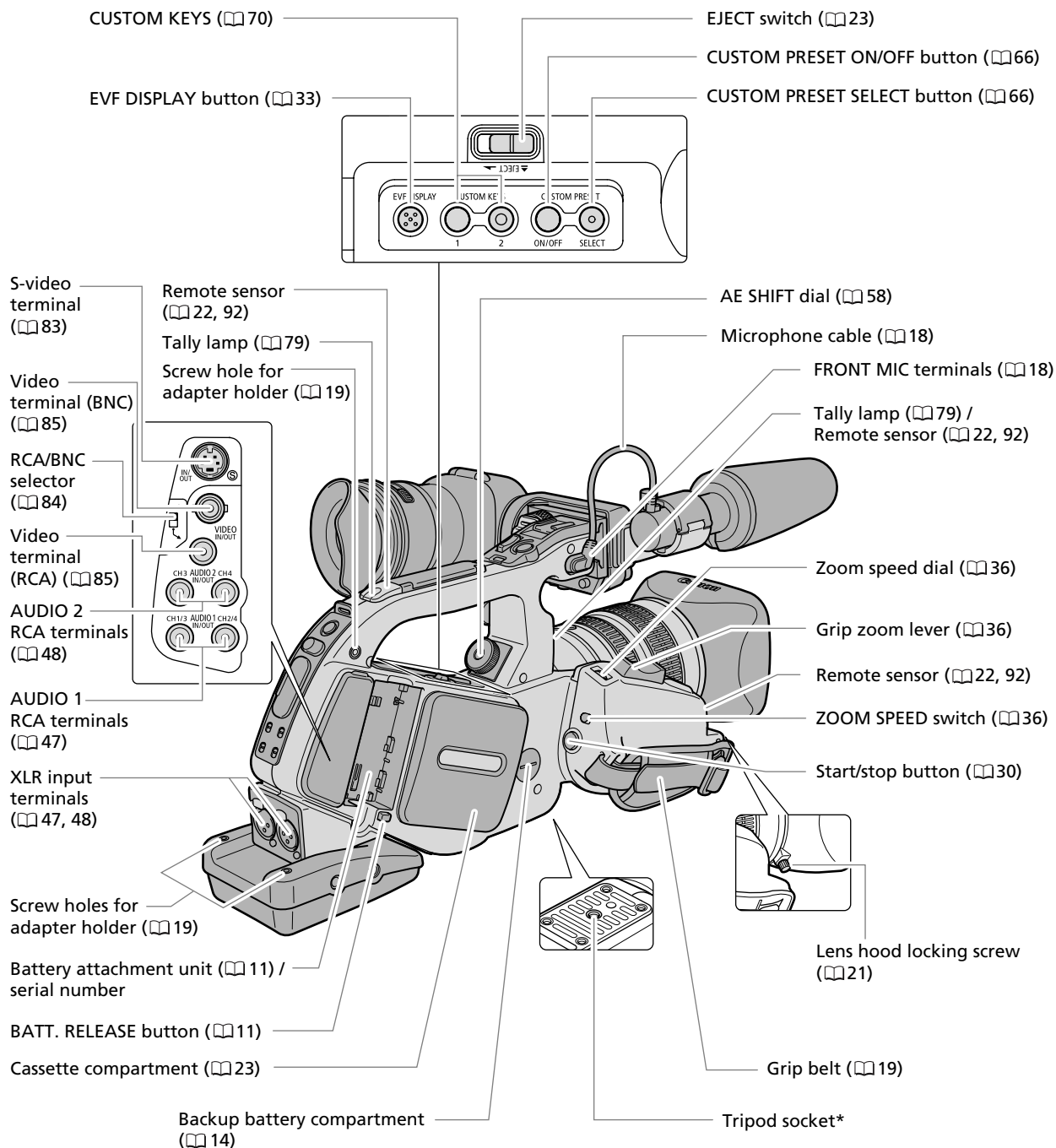



\* Do not use tripods with fastening screws longer than 5.5 mm as it may damage the camcorder.

### About the Terminal

 (LANC) stands for Local Application Control Bus System. The  terminal allows you to connect and control connected devices.

- Connect only devices with the  mark to the  terminal.
- Operation cannot be guaranteed for connections with devices not bearing the  mark.
- Some buttons of connected devices may not operate or may operate differently than the buttons on the camcorder.



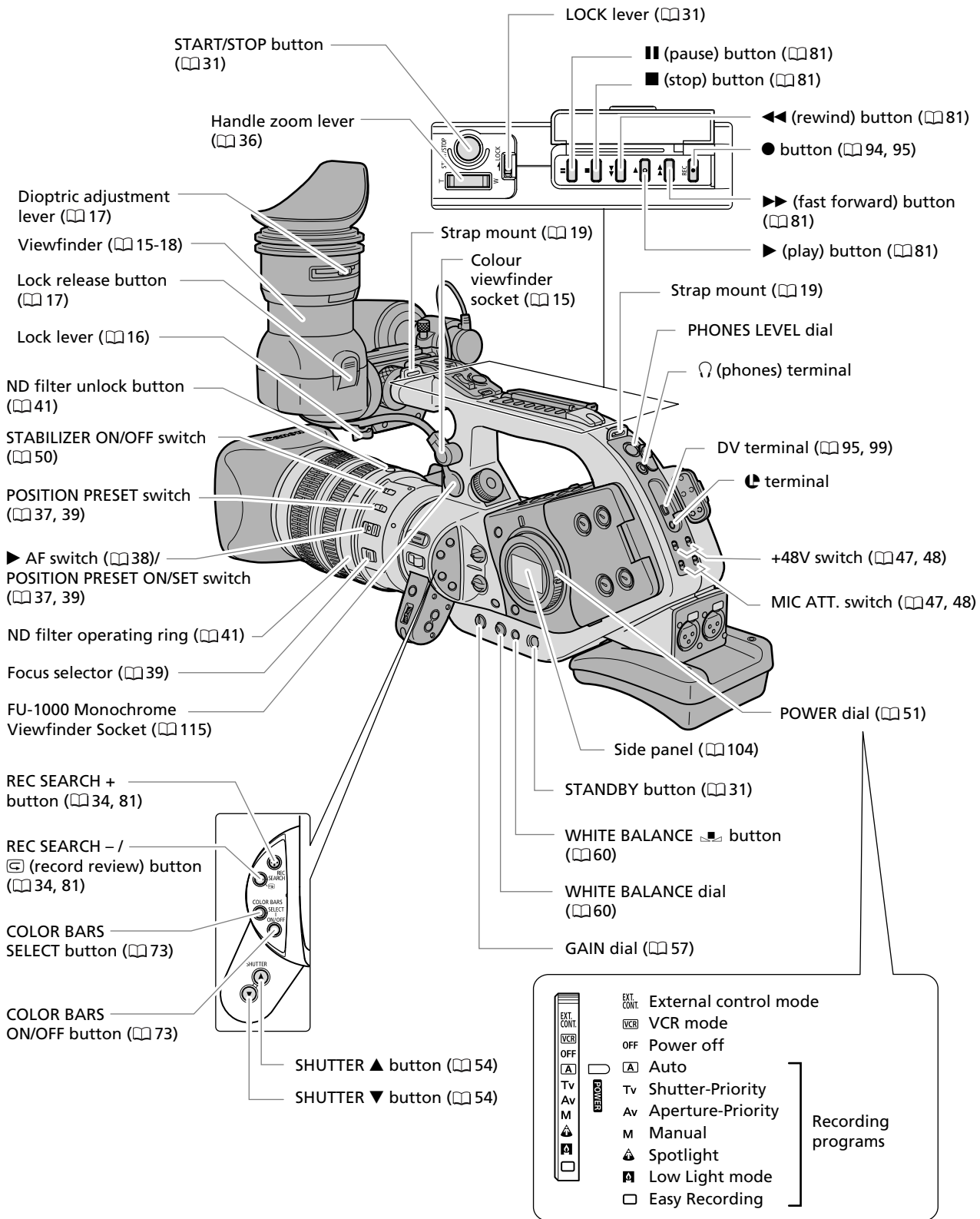

# WL-D4000 Wireless Controller

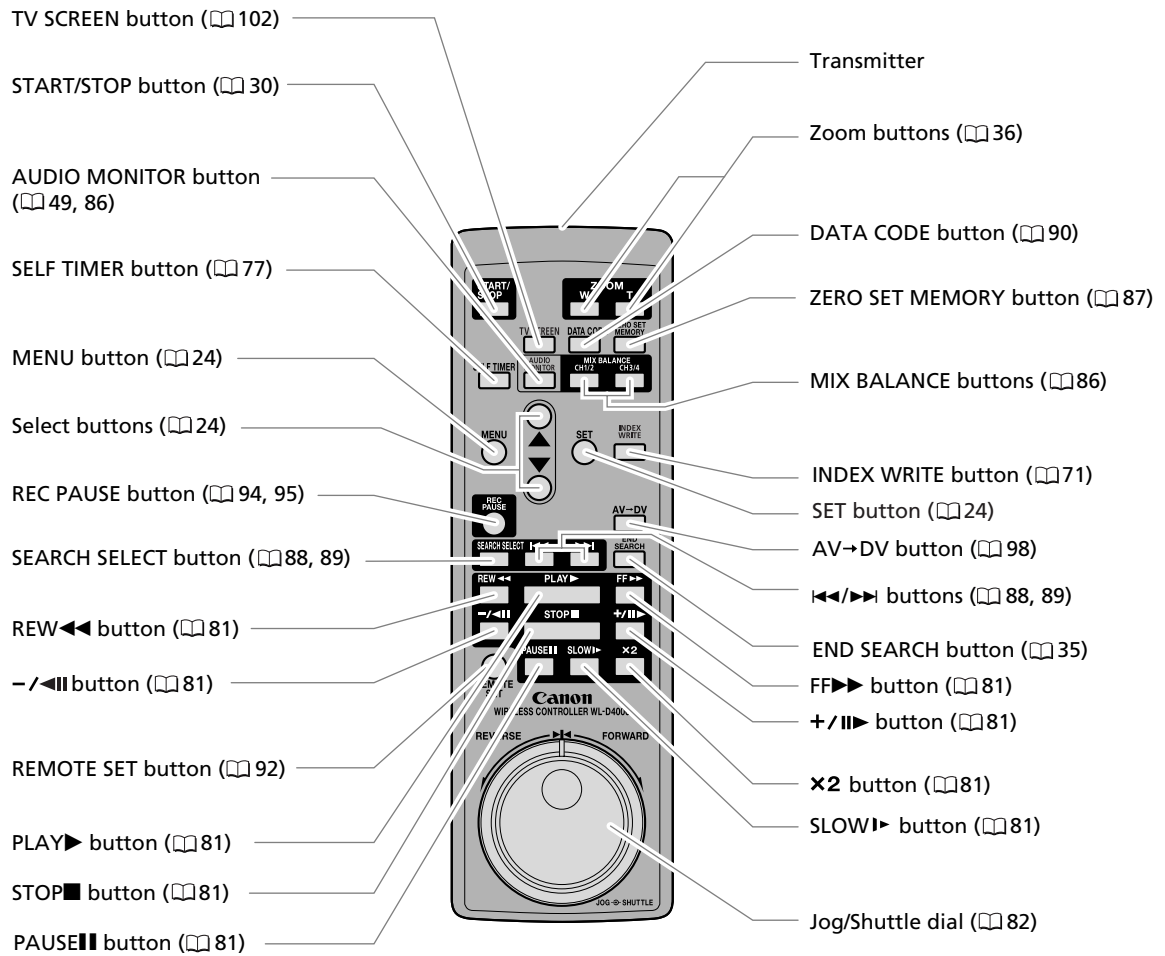

# Preparing the Power Supply

## Charging the Battery Pack

Disconnect the DC coupler from the power adapter before charging. Remove the terminal cover of the battery pack.

1. **Connect the power cord to the adapter.**
2. **Plug the power cord into a power outlet.**
3. **Attach the battery pack to the adapter.**
  - Press lightly and slide it in the direction of the arrow until it clicks.
  - The CHARGE indicator starts flashing. It glows steadily when charging is complete.
4. **When charging is complete, remove the battery pack from the adapter.**
5. **Unplug the power cord from the power outlet and disconnect it from the adapter.**

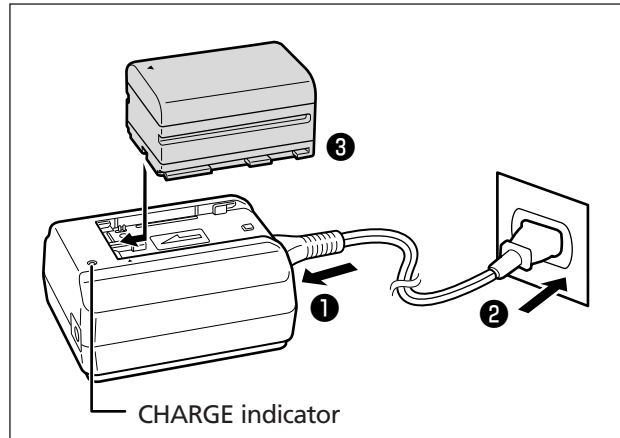

## Attaching the Battery Pack

1. **Turn the POWER dial to OFF.**
2. **Attach the battery pack to the camcorder.**

Press lightly and slide it in the direction of the arrow until it clicks.
3. **Remove the battery pack after use.**

Press the BATT. RELEASE button to remove the battery.

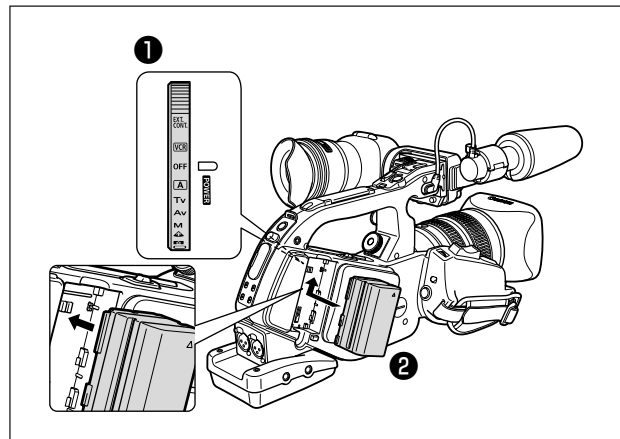

## Using a Household Power Source

- 1. Turn the POWER dial to OFF.**
- 2. Attach the DC coupler to the camcorder.**  
Press lightly and slide it in the direction of the arrow until it clicks.
- 3. Connect the power cord to the power adapter.**
- 4. Plug the power cord into a power outlet.**
- 5. Connect the DC coupler to the adapter.**
- 6. Detach the DC coupler after use.**  
Press the BATT. RELEASE button to detach the DC coupler.

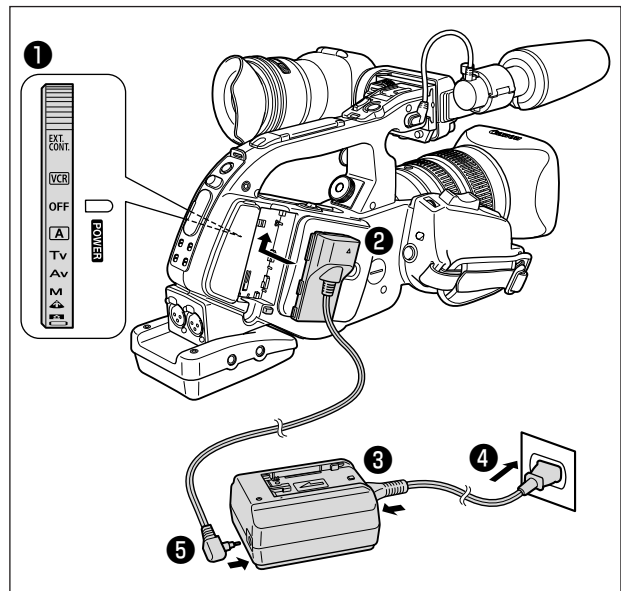

- Disconnect the DC coupler from the power adapter when charging a battery pack.
- Turn off the camcorder before connecting or disconnecting the power adapter.
- If the adapter is used close to a TV, it may cause picture interference. Move the adapter away from the TV or the aerial cable.
- Do not connect any products that are not expressly recommended to the power adapter.



- When the power adapter or battery pack is defective, the CHARGE indicator turns off, and charging stops.
- The CHARGE indicator informs you about the charge status.
  - 0-50%: Flashes once every second
  - 50-75%: Flashes twice every second
  - More than 75%: Flashes 3 times every second
  - 100%: Glows steadily

### ○ Charging, Recording and Playback Times

Below times are approximate and vary according to the charging, recording or playback conditions.

<b>Battery Pack</b>			<b>BP-930</b>	<b>BP-945</b>
Charging Time with the CA-920			145 min.	220 min.
With 20× L IS Lens	Maximum Recording Time	With supplied colour viewfinder	155 min.	230 min.
		With optional FU-1000 Monochrome Viewfinder	120 min.	185 min.
	Typical Recording Time*	With supplied colour viewfinder	90 min.	135 min.
		With optional FU-1000 Monochrome Viewfinder	65 min.	100 min.
With 16× Manual Zoom Lens	Maximum Recording Time	With supplied colour viewfinder	185 min.	280 min.
		With optional FU-1000 Monochrome Viewfinder	135 min.	205 min.
	Typical Recording Time*	With supplied colour viewfinder	105 min.	160 min.
		With optional FU-1000 Monochrome Viewfinder	75 min.	115 min.
Playback Time			235 min.	360 min.

\* Approximate times for recording with repeated operations such as start/stop, zooming, power on/off. Actual time may be shorter.

- We recommend charging the battery pack in temperatures between 10 °C and 30 °C. Outside the temperature range of 0 °C to 40 °C, the CHARGE indicator turns off, and charging stops.
- A lithium ion battery pack can be charged at any charge state. Unlike conventional battery packs, you do not need to completely use or discharge it before charging.
- We recommend that you prepare battery packs 2 to 3 times longer than you think you might need.
- To conserve battery power, turn off the camcorder instead of leaving it in record pause mode.

# Installing the Backup Battery

The backup battery (lithium button battery CR2025) allows the camcorder to retain date, time (📅 28) and other camcorder settings while the power source is disconnected. Connect a power source to the camcorder when replacing the backup battery to retain the settings.

## 1. Open the backup battery cover.

Screw the cover to the left (use, for example, a coin).

## 2. Insert the backup battery with the + side facing outward.

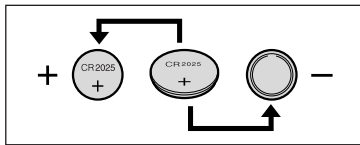

## 3. Close the cover.

Align the mark on the cover with the lower mark on the camcorder and screw the cover to the right until it clicks.

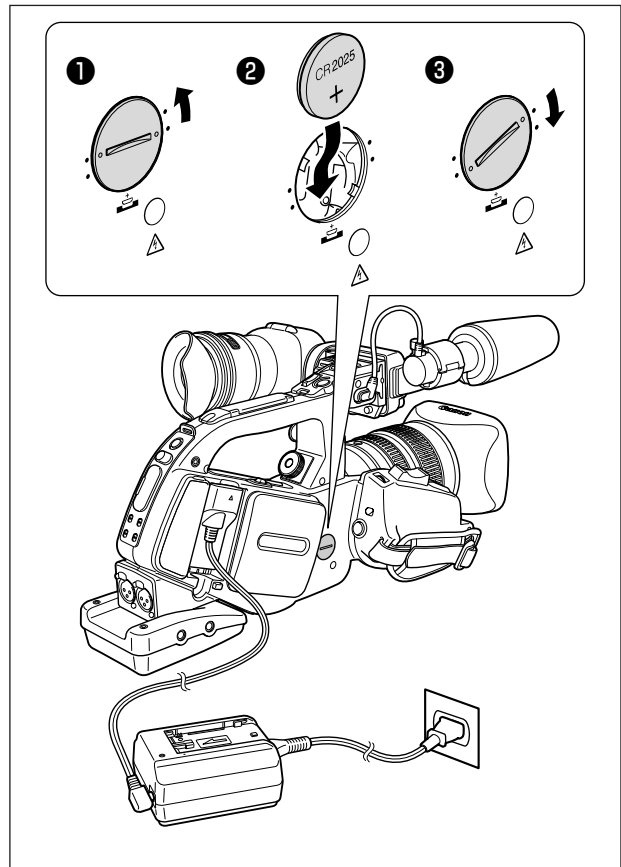

### WARNING!

- The battery used in this device may present a fire or chemical burn hazard if mistreated. Do not recharge, disassemble, heat above 100 °C or incinerate the battery.
- Replace the battery with a CR2025 made by Panasonic, Hitachi Maxell, Sony, Sanyo, or with Duracell DL2025. Use of other batteries may present a risk of fire or explosion.
- The used battery should be returned to the supplier for safe disposal.



- Do not pick up the battery using tweezers or other metal tools as this will cause a short circuit.
- Wipe the battery with a clean dry cloth to ensure proper contact.
- Keep the battery out of reach of children. If it is swallowed, seek medical assistance immediately. The battery case may break, and the battery fluids may damage stomach and intestines.
- Do not disassemble, heat or immerse the battery in water to avoid the risk of explosion.



The backup battery has a life span of about a year. “⚡” flashes in red to inform you that it needs to be replaced.

# Preparing the Camcorder

## Attaching and Detaching the Colour Viewfinder Unit

E

### Attaching the Colour Viewfinder Unit

1. Slide the viewfinder unit onto the bracket and tighten the locking screw.

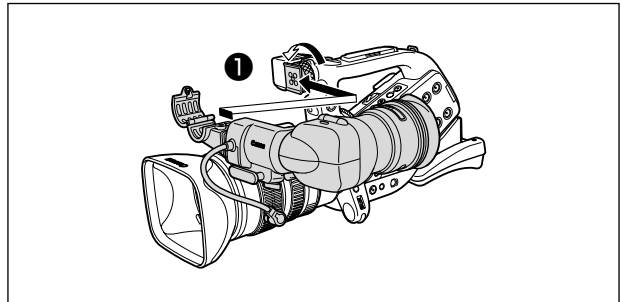

2. Connect the viewfinder cable to the upper socket of the camcorder body.  
Align the mark on the cable with the mark on the camcorder.
3. Hook the viewfinder cable onto the cable clamp.

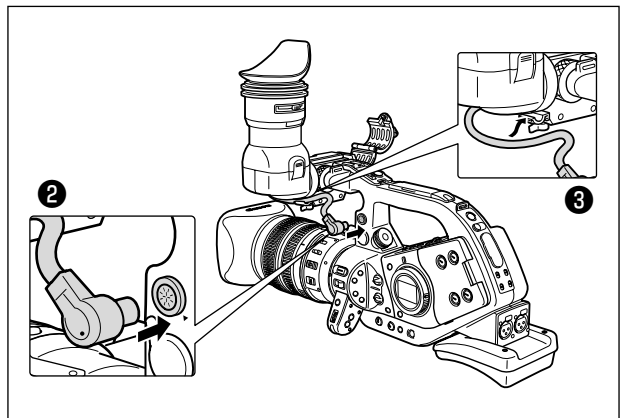

Preparation

### Detaching the Viewfinder Unit

1. Detach the viewfinder cable.
2. Loosen the locking screw and slide the viewfinder unit off the bracket.

## Detaching and Attaching the Eye Cup

You can change the position of the eye cup for use with either the left or right eye. Detach and reattach the eye cup for use with the left eye.

### Detaching the Eye Cup

Detach the eye cup as shown in the illustration.

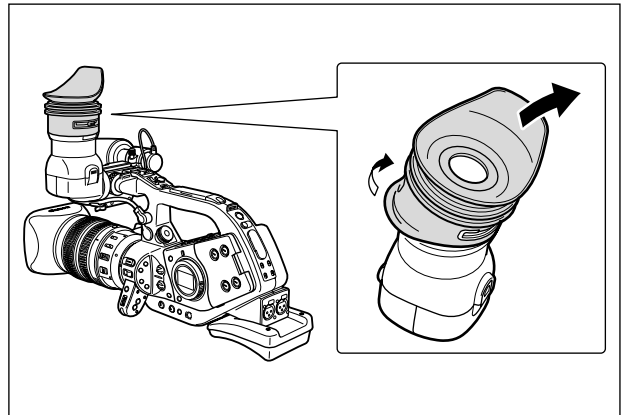

### Attaching the Eye Cup

Align the hole for the dioptic adjustment lever with the lever, and pull the eye cup into position.

Right eye use

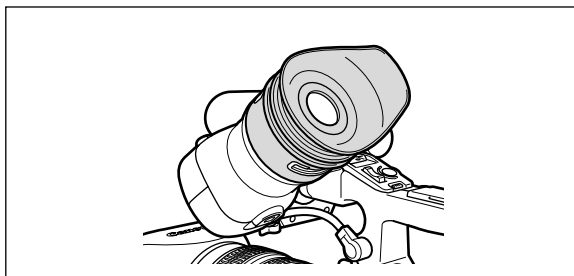

Left eye use

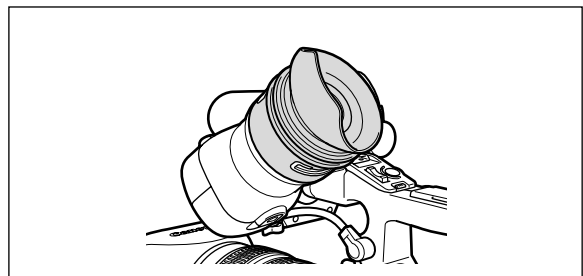

## Adjusting the Position of the Viewfinder

The viewfinder position can be changed (right/left, forward/backward).

### Right/Left Adjustment

Loosen the locking screw, move the viewfinder to the right/left and tighten the screw.

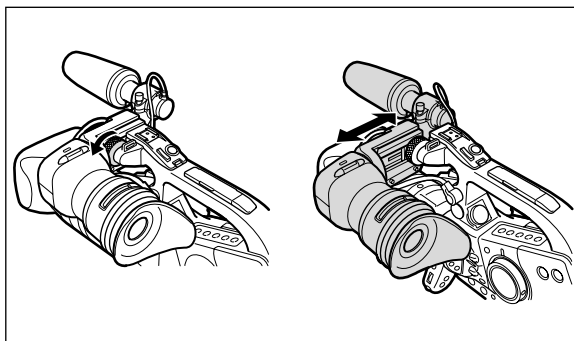

### Forward/Backward Adjustment

Loosen the locking lever, move the viewfinder forward/backward and tighten the lever.

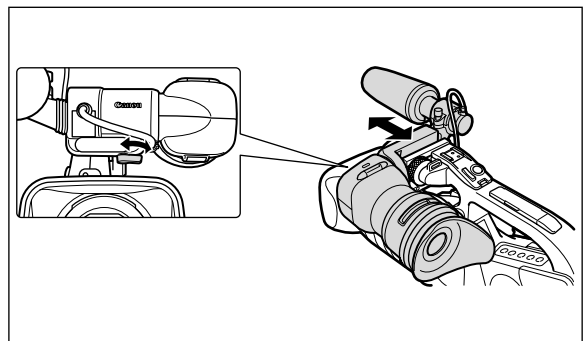



## Using the Viewfinder as LCD Panel

You can use the viewfinder as LCD panel by opening the eyepiece adapter.

**Press the lock release button and open the eyepiece adapter.**

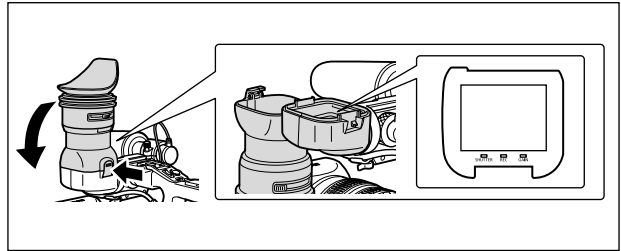

Make sure to close the eyepiece adapter when you are not using the viewfinder as LCD panel.



The screen is slightly brighter when you open the eyepiece adapter.

## Dioptric Adjustment

**Turn on the camcorder and adjust the dioptric adjustment lever.**

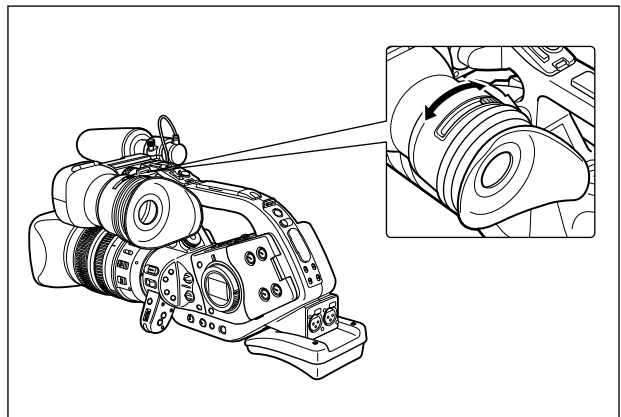

Prevent direct sunlight getting in the viewfinder. The viewfinder LCD may become damaged due to concentration of the light by the lens. Pay special attention when mounting the camcorder on a tripod, or during transportation.

## Adjusting the Viewfinder

You can adjust the brightness, contrast, colour and sharpness of the viewfinder. These adjustments will not affect the picture of your recording.

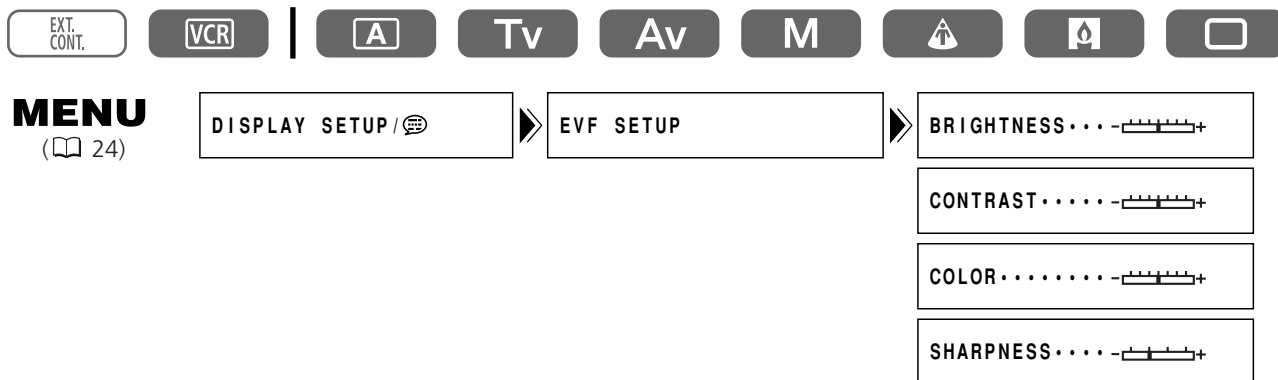

1. Press the MENU button to open the menu.
2. Turn the SET dial to select [DISPLAY SETUP/  ] and press the SET dial.
3. Turn the SET dial to select [EVF SETUP] and press the SET dial.
4. Turn the SET dial to select [BRIGHTNESS], [CONTRAST], [COLOR], or [SHARPNESS] and press the SET dial.
5. Turn the SET dial up or down to adjust the setting and press the SET dial.
6. Press the MENU button to close the menu.

## Attaching the Microphone Unit

1. Loosen the microphone locking screw on the viewfinder unit, open the microphone clamp and insert the microphone into the microphone clamp.
2. Align the mark on the microphone with the mark on the clamp and tighten the screw.
3. Plug the microphone cable to the camcorder's FRONT MIC terminals.

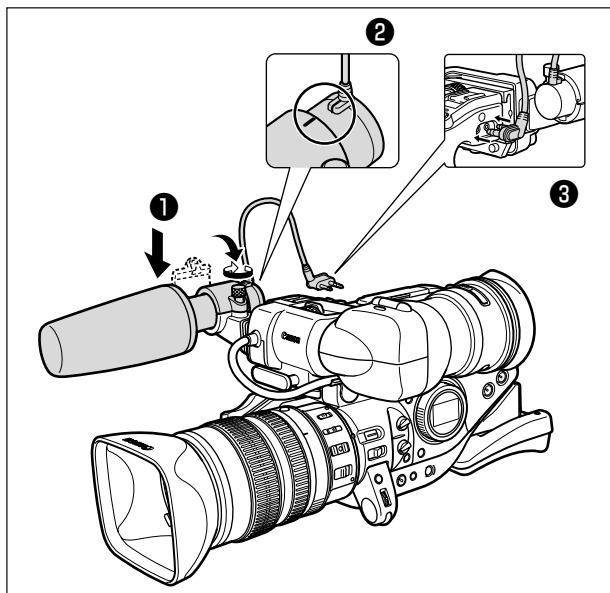

When using a microphone other than the supplied one, attach it to the advanced accessory shoe.

## Fastening the Grip Belt

**Hold the camcorder with your right hand and adjust the belt with your left.**

Adjust the grip belt so that you can reach the zoom lever with your index and middle finger, and the start/stop button with your thumb.

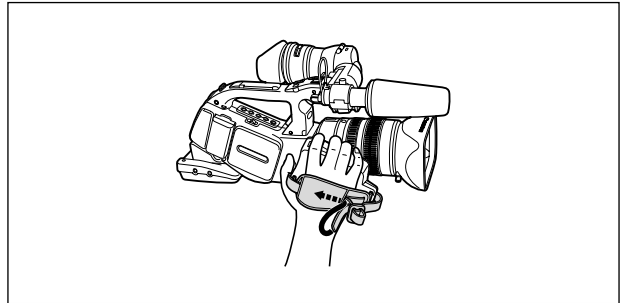

## Attaching the Shoulder Strap

**Pass the ends through the strap mount and adjust the length of the strap.**

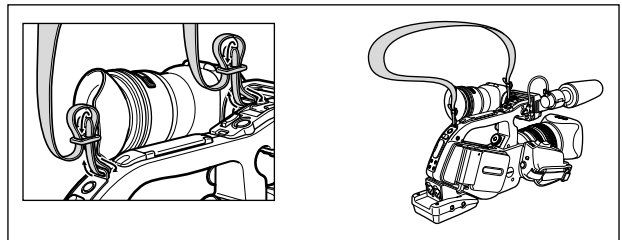

Be careful not to drop the camcorder when adjusting the strap.

## Attaching the Adapter Holder

Attach the adapter holder to use the optional CH-910 Dual Battery Charger/Holder or a commercially available wireless microphone receiver.

**1. Attach the adapter holder and secure it by tightening the screws.**

**2. Adjust the position of the support bars.**

When using the optional CH-910, hook it onto the support bars and secure it with the stop lever. To detach the CH-910, press the stop lever in the direction of the arrow and pull it off the support bars.

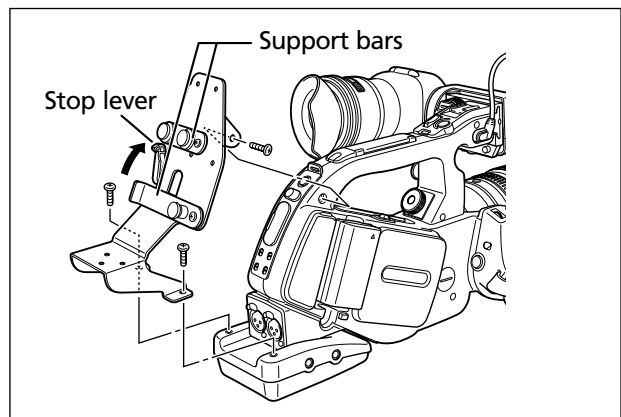

# Preparing the Lens

Refer also to the instruction manual of the lens.

## Mounting the Lens

1. Set the POWER dial to OFF.
2. Remove the dust caps from the camcorder and the lens.
3. Align the red mark on the lens with the red mark on the camcorder and turn the lens clockwise until it clicks.

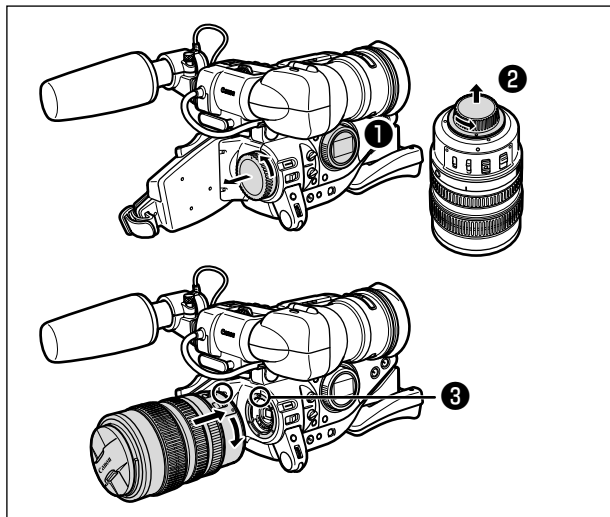

## Unmounting the Lens

1. Set the POWER dial to OFF.
2. Slide the LENS RELEASE switch, turn the lens counter-clockwise until it stops and remove the lens.
3. Attach the dust caps to the camcorder and the lens.

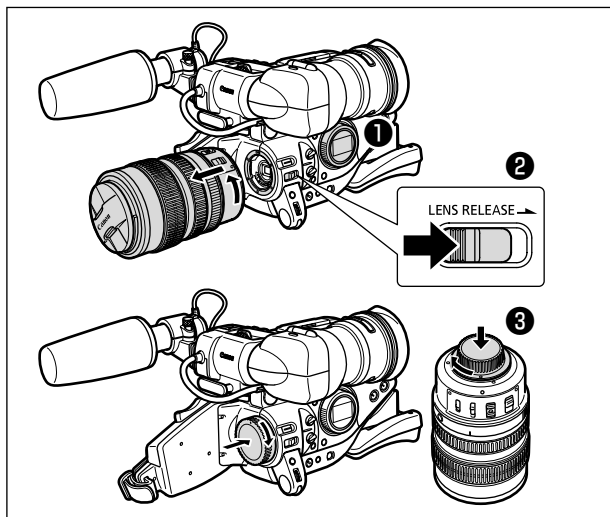

- Be careful not to drop the lens or camcorder when mounting/unmounting the lens.
- Avoid direct sunlight or strong light sources when mounting/unmounting the lens.
- The XL mount is not compatible with the VL mount.
- Do not touch the lens, lens mount and the interior of the mount, or expose them to dust or dirt. If necessary, clean it with a dry soft cloth (make sure to turn off the camcorder during cleaning).

## Attaching the Lens Hood

Attach the lens hood to shade the lens from stray light and to protect the lens.

**1. Place the lens hood on the front of the lens and screw it clockwise until the Canon logo appears on top.**

- Be careful not to deform the lens hood.
- Make sure that the lens hood is aligned with the thread.

**2. Tighten the locking screw.**

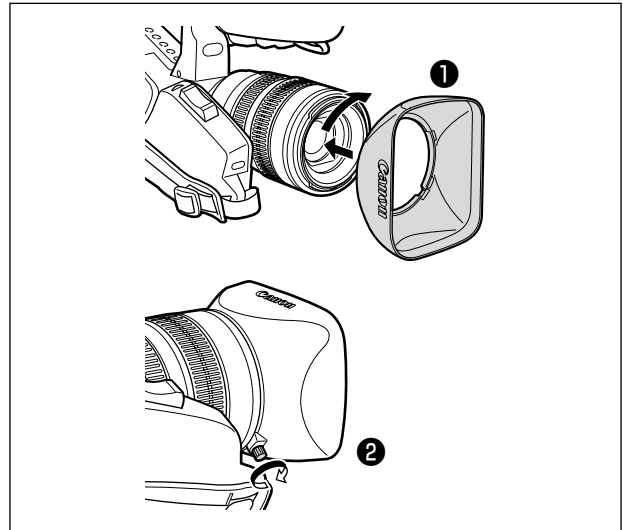

# Using the Wireless Controller

**Point it at the camcorder's remote sensor when you press the buttons.**

The camcorder has three remote sensors, two at the front and one at the back.

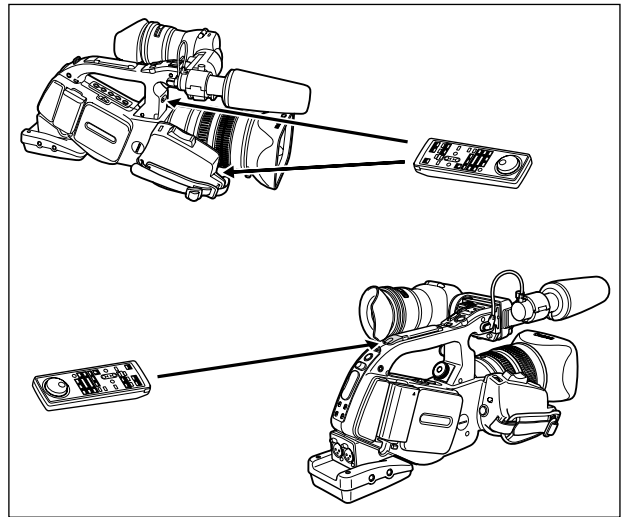

## Inserting Batteries

The wireless controller operates with two AAA (R03) batteries.

1. **Open the battery cover.**
2. **Insert the batteries following the + and – markings.**
3. **Close the battery cover.**

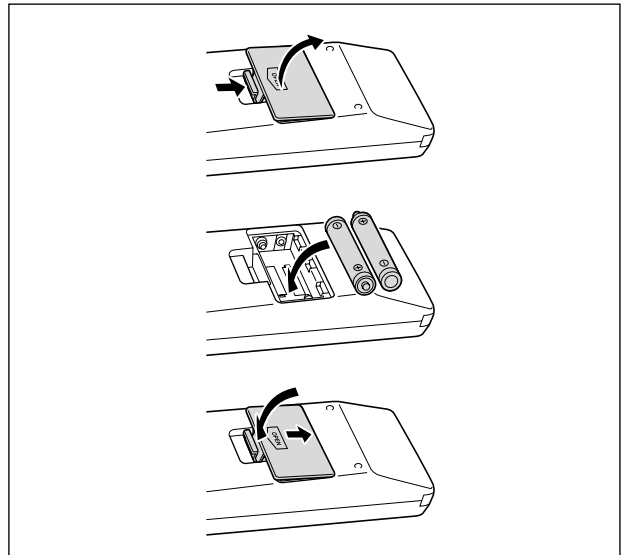

- Camcorder and wireless controller are equipped with 2 remote sensor modes ( 92). If the wireless controller does not work, check if camcorder and wireless controller are set to the same mode.
- When the camcorder cannot be operated with the wireless controller, or when it can only be operated in very close range, replace the batteries. Make sure to replace both batteries at the same time.
- The wireless controller may not work properly when the remote sensor is subjected to strong light sources or direct sunlight.

# Loading/Unloading a Cassette

Use only videocassettes marked with the Mini DV logo.

## 1. Slide the EJECT switch to open the cassette compartment cover.

The cassette compartment opens automatically.

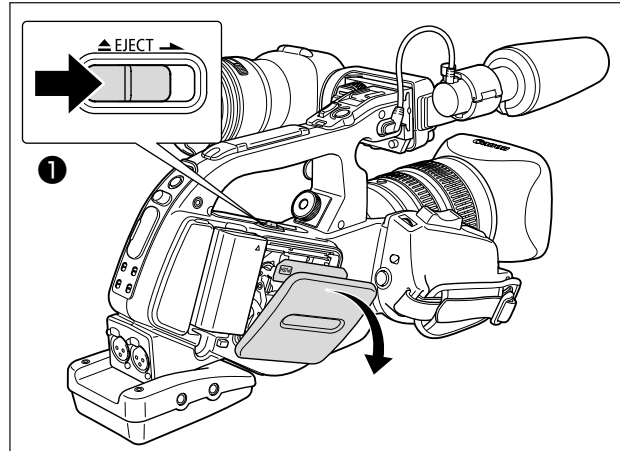

## 2. Load/unload the cassette.

- Load the cassette with the window facing outward.
- Unload the cassette by pulling it straight out.

## 3. Press the **PUSH** mark on the cassette compartment until it clicks.

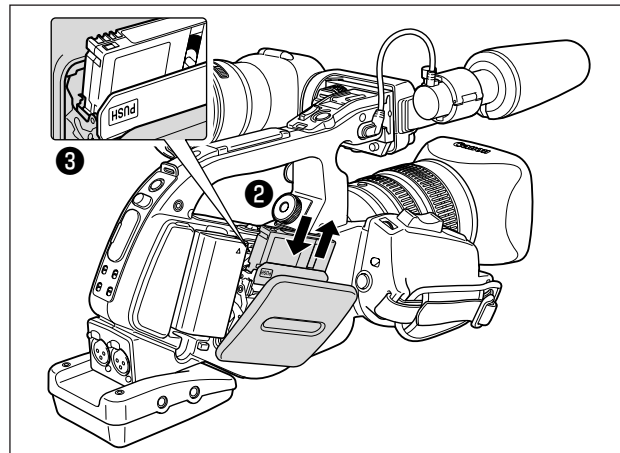

## 4. Wait for the cassette compartment to retract automatically and close the cassette compartment cover.

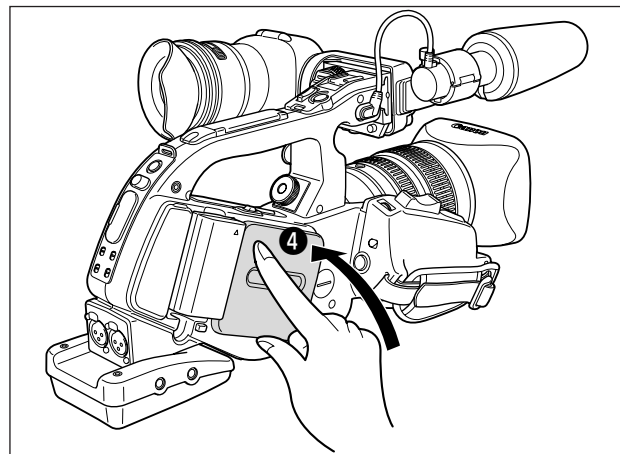

○ Do not interfere with the cassette compartment while it is opening or closing automatically, or attempt to close the cover before the cassette compartment has fully retracted.

○ Be careful not to get your fingers caught in the cassette compartment cover.



If the camcorder is connected to a power source, cassettes can be loaded/unloaded even if the POWER dial is set to OFF.

# Menus and Settings

---

Many of the camcorder's functions are selected from menus that appear on the screen.

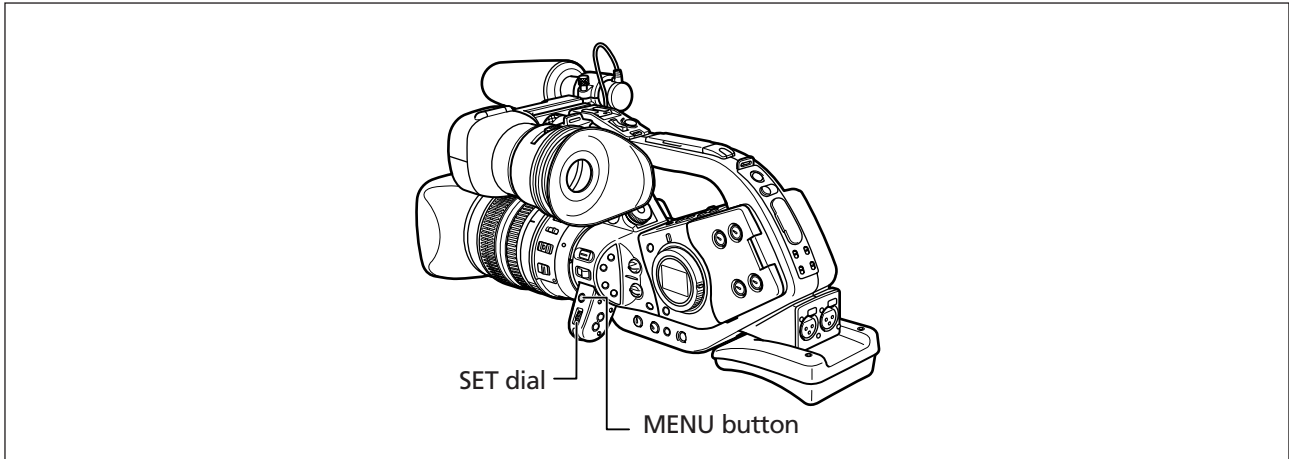

## Selecting Menus and Settings

---

1. Press the MENU button to open the menu.
2. Turn the SET dial to select a submenu and press the SET dial.
3. Turn the SET dial to select a menu item and press the SET dial.
4. Turn the SET dial to select a setting option and press the SET dial.
5. Press the MENU button to close the menu.









- Pressing the MENU button at any time closes the menu.
- Items that are not available appear in purple.
- You may find it more convenient to use the wireless controller to operate the menu. Press the MENU button on the wireless controller to open or close the menu. Use the select buttons in place of the SET dial and press the SET button in place of pressing the SET dial.



## Menu and Default Settings

Default settings are shown in boldface.

### CAMERA MENU

Submenu	Menu Item	Setting Options		
TIME CODE	COUNT-UP	<b>REC-RUN</b> , REC-RUN PS., FREE-RUN	44	
	START VALUE	<b>SET</b> , RESET		
CAMERA SETUP	ZEBRA	<b>ON</b> , <b>OFF</b>	62	
	ZEBRA LEVEL	80, 85, <b>90</b> , 95, 100		
	SKIN D.SET	HUE		63
		CHROMA		
		AREA		
		Y LEVEL		
		SKIN DETAIL	<b>OFF</b> , HIGH  , MIDDLE  , LOW 	
	ZOOM HANDLE	<b>LOW</b> , <b>MIDDLE</b> , HIGH		36
	F SPEED PSET*	<b>LOW</b> , <b>MIDDLE</b> , <b>HIGH</b>		40
	CLEAR SCAN			69
	SELF TIMER	<b>ON</b>  , <b>OFF</b>		77
	INTERVAL T.	<b>ON</b> , <b>OFF</b>		75
INTERVAL	<b>30sec</b> , 1min, 5min, 10min			
INT. REC TIME	<b>0.5sec</b> , 1sec, 1.5sec, 2sec			
CUSTOM PRESET	PRESET SETUP	SEL PRESET	<b>1 PRESET_A</b> , 2 PRESET_B, 3 PRESET_C	66
		 /CLEAR	<b>CANCEL</b> , PROTECT  , CLEAR	
		GAMMA	<b>NORMAL</b> , CINE	
		KNEE	HIGH, <b>MIDDLE</b> , LOW	
		BLACK	STRETCH, <b>MIDDLE</b> , PRESS	
		COLOR MATRIX	<b>NORMAL</b> , CINE	
		COLOR GAIN		
		COLOR PHASE		
		R GAIN		
		G GAIN		
		B GAIN		
		V DETAIL	<b>NORMAL</b> , LOW	
		SHARPNESS		
		CORING		
		SETUP LEVEL		
		MASTER PED.		
		NR	<b>OFF</b> , HIGH, MIDDLE, LOW	
		READ PRESET	SEL PRESET	
	SEL POSITION			
	VCR SETUP	REC MODE	<b>SP</b> , LP	79
POWER SAVE		<b>SHUT OFF</b> , VCR STOP	31	
USR BIT DATA		<b>SET</b> , CLEAR	45	

\* Can only be selected when a lens with focus preset function is mounted.

Submenu	Menu Item	Setting Options	📖
AUDIO SETUP	AUDIO MODE	16bit, 12bit CH (1/2), 12bit CH (1/2), (3/4)	46
	1kHz TONE	OFF, -12dB, -20dB	74
	AUD.M.SET	NORMAL, LINE OUT	49
	R-XLR GAINUP	OFF, 12dB	47
DISPLAY SETUP/ 🗨	EVF SETUP	BRIGHTNESS	18
		CONTRAST	
		COLOR	
		SHARPNESS	
	CENTER MARK	ON, OFF	33
	TV SCREEN	ON, OFF	102
	AUDIO LEVEL	ON, OFF	49
	GUIDE INFO	OFF, CUSTOM KEYS, D/T DISPLAY	29, 70
	LANGUAGE 🗨	ENGLISH, 中文, 日本語	80
	DATE FORMAT		80
	USR BIT DISP	ON, OFF	45
SYSTEM	CUSTOM KEY 1	TIME CODE, INDEX WRITE, ZEBRA, VCR STOP, TV SCREEN, ZOOM HANDLE, AUDIO LEVEL, (NONE)	71
	CUSTOM KEY 2	TIME CODE, INDEX WRITE, ZEBRA, VCR STOP, TV SCREEN, ZOOM HANDLE, AUDIO LEVEL, (NONE)	
	WL.REMOTE	📺1, 📺2, OFF 📺	92
	TALLY LAMP	ON, OFF	79
	T.ZONE/DST		28
	D/TIME SET		28
	CHAR.REC	ON, OFF	79
	DV CONTROL	ON, OFF	78

## VCR MENU

Submenu	Menu Item	Setting Options	
TIME CODE	COUNT-UP	REC-RUN, REC-RUN PS., FREE-RUN	44
	START VALUE	SET, RESET	
VCR SETUP	REC MODE	SP, LP	79
	AV→DV	ON, OFF	98
	USR BIT DATA	SET, CLEAR	45
AUDIO SETUP	SEL AUDIO CH	CH <span style="border: 1px solid black; padding: 0 2px;">1/3</span> /CH <span style="border: 1px solid black; padding: 0 2px;">2/4</span> , CH <span style="border: 1px solid black; padding: 0 2px;">1/3</span> /CH <span style="border: 1px solid black; padding: 0 2px;">1/3</span> , CH <span style="border: 1px solid black; padding: 0 2px;">2/4</span> /CH <span style="border: 1px solid black; padding: 0 2px;">2/4</span>	86
	MIX SELECT	VARIABLE, FIXED	86
	AUDIO MODE	16bit, 12bit CH <span style="border: 1px solid black; padding: 0 2px;">1/2</span> , 12bit CH <span style="border: 1px solid black; padding: 0 2px;">1/2</span> , <span style="border: 1px solid black; padding: 0 2px;">3/4</span>	46
	R-XLR GAINUP	OFF, 12dB	47
DISPLAY SETUP/ 	EVF SETUP	BRIGHTNESS	18
		CONTRAST	
		COLOR	
		SHARPNESS	
	TV SCREEN	ON, OFF	102
	AUDIO LEVEL	ON, OFF	49
	DISPLAYS	ON, OFF<PLAYBK>	102
	6SEC.DATE	ON, OFF	91
	DATA CODE	DATE/TIME, CAMERA DATA, CAM.& D/T	90
	D/TIME SEL.	DATE, TIME, DATE & TIME	90
	CUSTOM KEYS	ON, OFF	70
	LANGUAGE 	ENGLISH, 中文, 日本語	80
	DATE FORMAT		80
	USR BIT DISP	ON, OFF	45
SYSTEM	CUSTOM KEY 1	TIME CODE, TV SCREEN, DATA CODE, AUDIO LEVEL, (NONE)	71
	CUSTOM KEY 2	TIME CODE, TV SCREEN, DATA CODE, AUDIO LEVEL, (NONE)	
	WL.REMOTE	 1,  2, OFF 	92
	TALLY LAMP	ON, OFF	79
	T.ZONE/DST		28
	D/TIME SET		28

# Setting the Time Zone, Date and Time

---

Set the time zone, date and time when you first start using your camcorder, or when you have replaced the backup battery.

## Setting the Time Zone/Daylight Saving Time

---

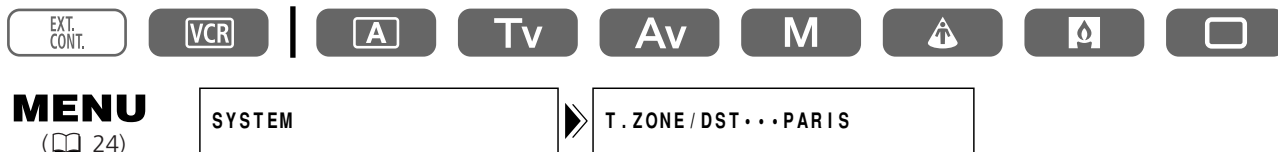

1. Press the MENU button to open the menu.
2. Turn the SET dial to select [SYSTEM] and press the SET dial.
3. Turn the SET dial to select [T.ZONE/DST] and press the SET dial.  
The time zone setting appears (see table on the next page). The default setting is Paris.
4. Turn the SET dial to select the setting option that represents your time zone and press the SET dial.

To adjust for daylight saving time, select the time zone with the ☀ next to the area.

## Setting the Date and Time

---

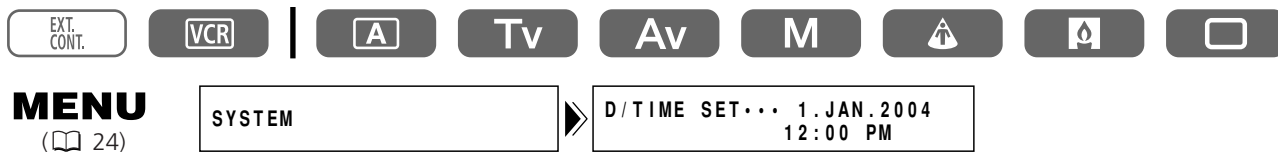

5. Turn the SET dial to select [D/TIME SET] and press the SET dial.  
The year display starts flashing.
6. Turn the SET dial to select the year, and press the SET dial.
  - The next part of the display starts flashing.
  - Set the month, day, hours and minutes in the same way.
7. Press the MENU button to close the menu and to start the clock.

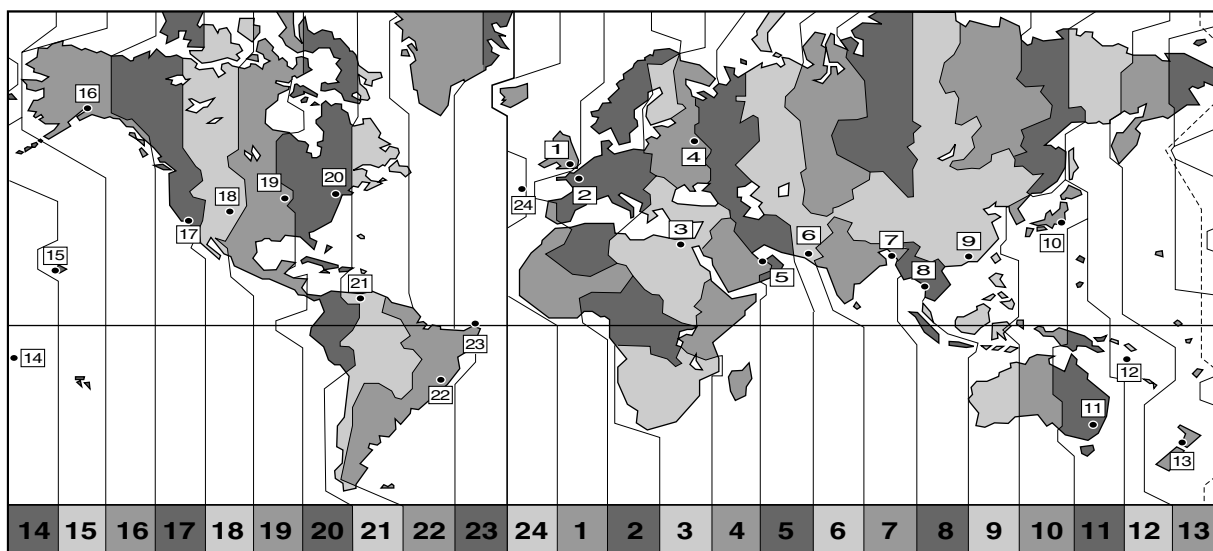

No.	Time zone	No.	Time zone
1	LONDON	13	WELLGTN (Wellington)
2	PARIS	14	SAMOA
3	CAIRO	15	HONOLU. (Honolulu)
4	MOSCOW	16	ANCHOR. (Anchorage)
5	DUBAI	17	L.A. (Los Angeles)
6	KARACHI	18	DENVER
7	DACCA	19	CHICAGO
8	BANGKOK	20	N.Y. (New York)
9	H. KONG (Hong Kong)	21	CARACAS
10	TOKYO	22	RIO (Rio de Janeiro)
11	SYDNEY	23	FERNAN. (Fernando de Noronha)
12	SOLOMON	24	AZORES



Once you have set time zone, date and time, you do not need to reset the clock each time you travel to another time zone. Just set the time zone to the one of your destination, and the camcorder automatically adjusts the clock.

## Displaying Date and Time during Recording

You can display the date and time in the lower left corner of the screen.



### MENU

( 24)

DISPLAY SETUP/ [🗨️]



GUIDE INFO...OFF

Open the menu and select [DISPLAY SETUP/ [🗨️]]. Select [GUIDE INFO], set it to [D/T DISPLAY] and close the menu.

# Recording

## Before You Begin Recording

Make a test recording first to check if the camcorder operates correctly. If necessary, clean the video heads (📖 108).

## Recording



1. Remove the lens cap.
2. Press the button and set the POWER dial to a recording program.

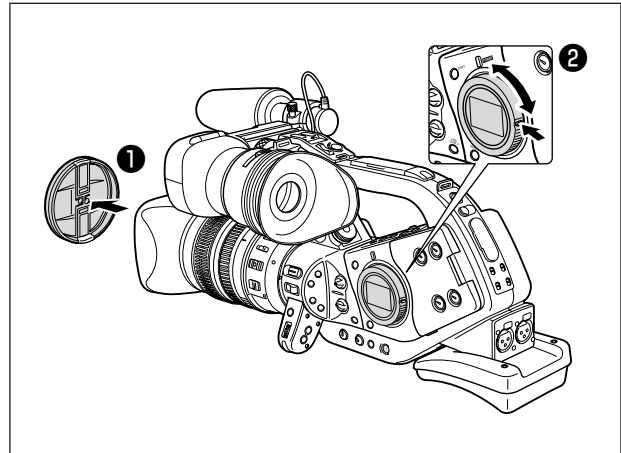

3. Press the start/stop button to begin recording.
  - The tally lamp starts flashing, and the REC lamp on the viewfinder lights up.
  - Press the start/stop button again to pause recording.

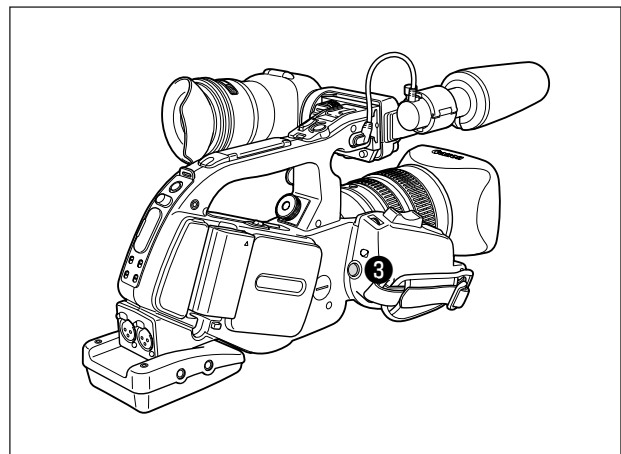

## When You Have Finished Recording

1. Set the POWER dial to OFF.
2. Replace the lens cap.
3. Unload the cassette.
4. Disconnect the power source.



- Wait until the tape counter stops completely before you start recording.
- When you do not remove the cassette, you can record the next scene without producing any noise or blank sections between the recordings even if you turn the camcorder off.

## Low-angle Recording

The carrying handle is equipped with a duplicate set of recording and zoom controls, ideal for low-angle recording. Slide the LOCK lever to the right to prevent accidental operation.

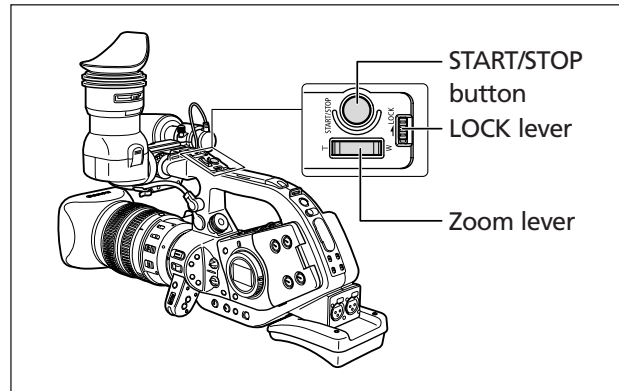

## Power Saving Mechanisms

### STANDBY Button

Pressing the STANDBY button for more than 1 second in record pause or VCR STOP mode activates the power save mode (“ENTERING POWER STANDBY” appears). This shuts the power down to the camera and VCR sections while maintaining the camera settings. The camcorder retains the settings of exposure lock and colour bars. Press the STANDBY button again to turn the camcorder back on.

### Power Save Function

The camcorder activates the power save function after 5 minutes in record pause mode to protect tape and video heads. You have the option to set the camcorder to shut off (SHUT OFF) or to turn off the VCR section leaving the camera section turned on (VCR STOP). In VCR STOP mode, the camcorder retains camera settings such as aperture and shutter speed, so you can adjust the camera section without worrying about the automatic shut-off. The VCR STOP function can also be assigned to a custom key ( 70).



### MENU

( 24)

VCR SETUP

▶ POWER SAVE...SHUT OFF

Open the menu and select [VCR SETUP]. Select [POWER SAVE], select a setting option and close the menu.



- When set to [SHUT OFF]: To turn the camcorder on, press the STANDBY button or set the POWER dial to OFF and then back to a recording program.
- When set to [VCR STOP]: To start recording, press the start/stop button. To go into record pause mode, use the custom key ( 70).

## Screen Displays during Recording

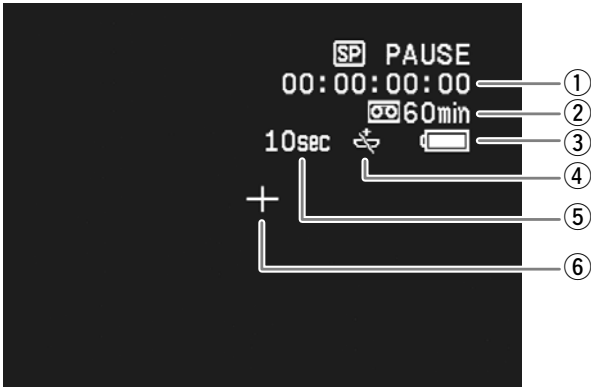

### ① Time code

Indicates the recording time in hours, minutes, seconds and frames (📖 44).

### ② Remaining tape

Indicates the remaining time of the tape in minutes. "END" flashes when the tape reaches the end.

- When the time left is less than 15 seconds, the remaining tape time may not appear.
- Depending on the type of the tape, the indication may not be displayed correctly.

### ③ Remaining battery charge

The battery symbol indicates the charge status of the battery pack.



- "🔋" starts flashing in red when the battery pack is empty.
- When you attach an empty battery pack, the power may turn off without displaying "🔋".
- The actual battery charge may not be indicated accurately depending on the condition under which battery pack and camcorder are used.

### ④ When "🔋" flashes

"🔋" flashes in red when the lithium button battery is not installed, or when it needs replacing.

### ⑤ Recording reminder

The camcorder counts from 1 to 10 seconds when you start recording. This is helpful to avoid scenes that are too short.

### ⑥ Centre marker

Use the centre marker to accurately frame subjects (📖 33).

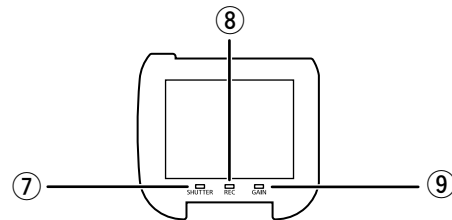

### ⑦ SHUTTER lamp

Lights up when the shutter speed is changed from the following:

50i	1/50 of a second
25p	1/25 of a second

### ⑧ REC lamp

Lights up during recording.

The REC lamp starts flashing when the remaining tape is less than 5 minutes (it does not flash when the remaining tape information is not displayed on the screen.)

### ⑨ GAIN lamp

Lights up when the AGC (auto gain control) becomes set to -3 dB or +3 dB or higher.





You can select the amount of information shown on the screen from full, partial or no display. The setting changes with each press of the EVF DISPLAY button.

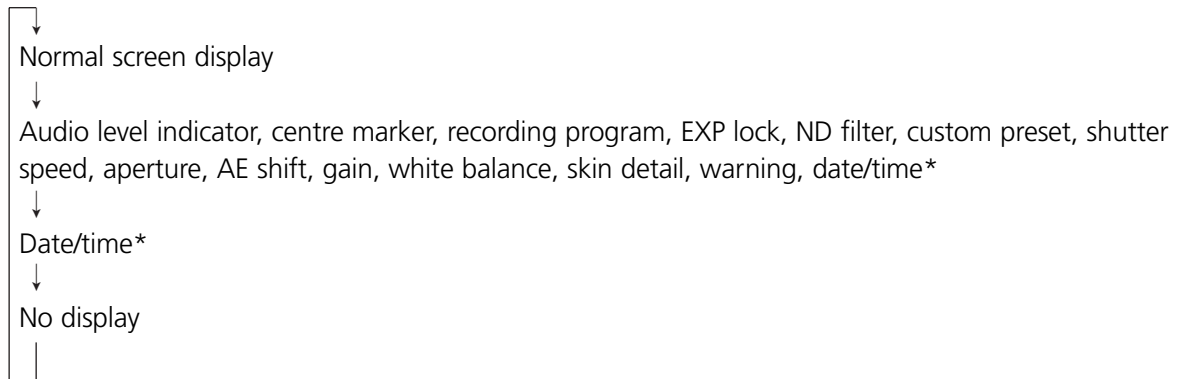

\* When [GUIDE INFO] is set to [D/T DISPLAY].

## Displaying the Centre Marker

Use the centre marker to accurately frame subjects.



### MENU

( 24)

DISPLAY SETUP /

CENTER MARK · · OFF

Open the menu and select [DISPLAY SETUP/ ]. Select [CENTER MARK], set it to [ON] and close the menu.

## Reviewing and Searching when Recording

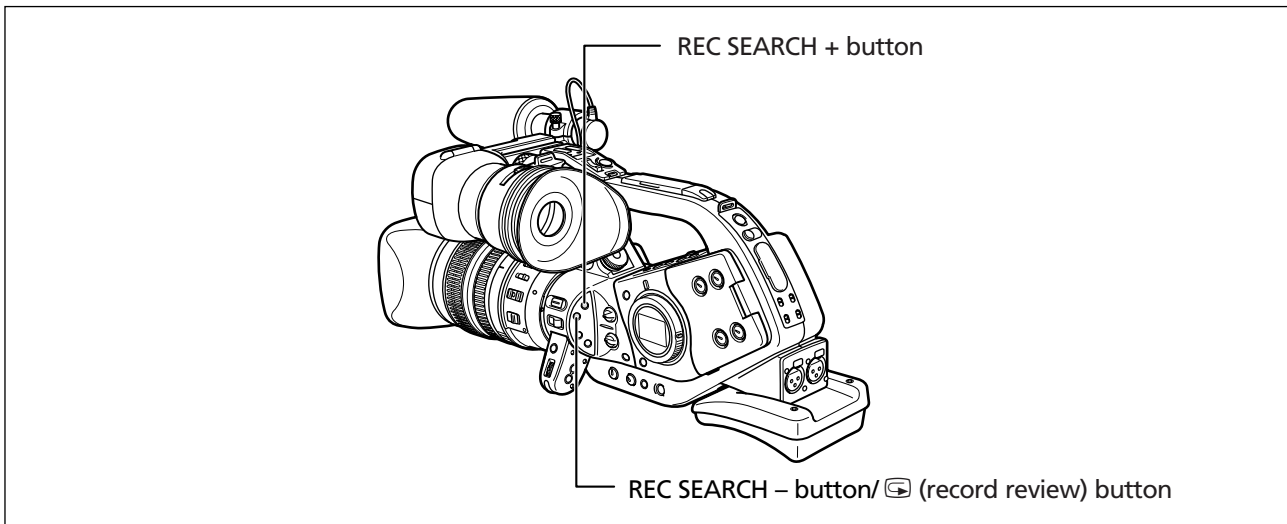

### Record Review



In record pause mode, this function allows you to review the last few seconds of your recording to check if it has been recorded properly.

#### Press and release the (record review) button.

The camcorder rewinds the tape, plays back the last few seconds, and returns to record pause mode.

### Record Search



In record pause mode, this function allows you to play back the tape (forward or reverse) to locate the point where you wish to begin recording.

#### Press and hold the REC SEARCH + button (forward) or – button (reverse).

- Release the button at the point you wish to begin recording.
- The camcorder returns to record pause mode.

# End Search

You can use this function to locate the end of the last recorded scene.

E

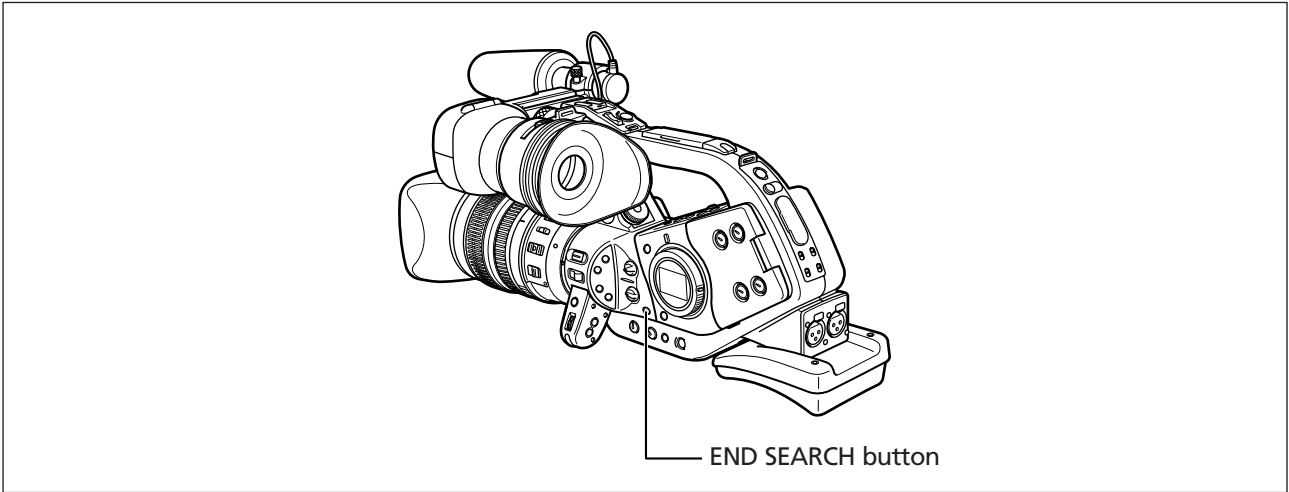

**Press the END SEARCH button.**

- "END SEARCH" appears.
- The camcorder rewinds/fast forwards the tape, plays back the last few seconds of the recording and stops the tape.
- Pressing the button again cancels the search.



- End search cannot be used once you unload the cassette.
- End search may not work properly if a blank section exists on the tape.

Recording

# Zooming

You can operate the zoom from either the side grip or the carrying handle. You can also use the zoom ring on the zoom lens or the zoom buttons on the wireless controller.

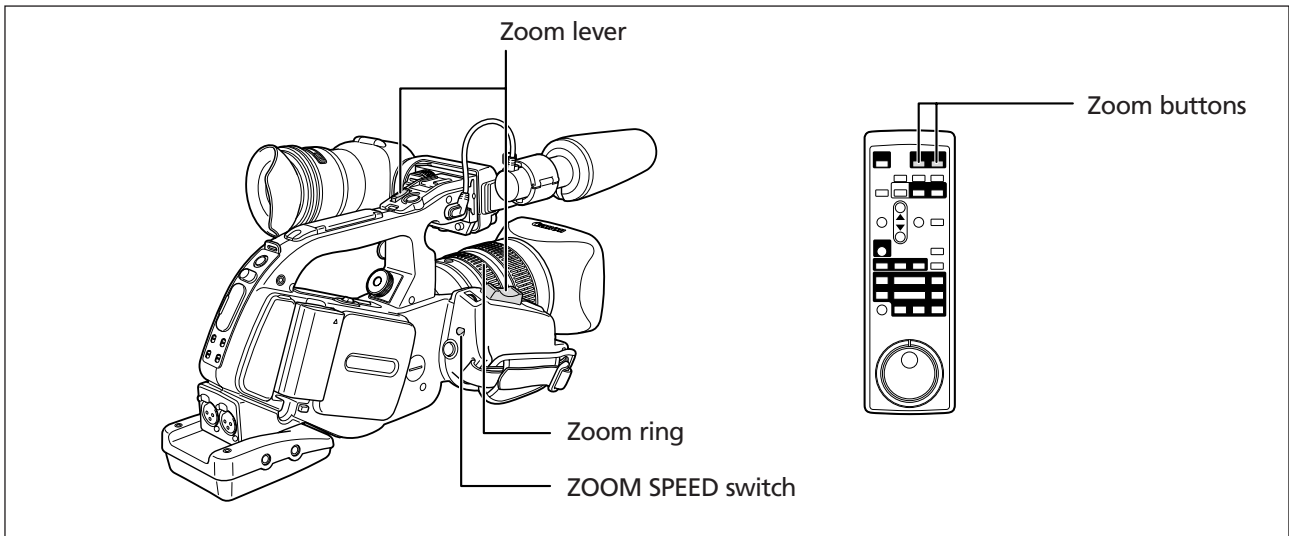

Move the zoom lever toward **W** to zoom out (wide-angle). Move it toward **T** to zoom in (telephoto).

## About the Variable Zoom Speeds

### Zoom lever on the side grip:

When the ZOOM SPEED switch is set to CONSTANT, the zoom speed is constant. However, you can change the zoom speed with the dial above (a number indicating the level is displayed next to the zoom indicator).

When the ZOOM SPEED switch is set to VARIABLE, the zoom speed is linked to how hard you move the zoom lever.

### Zoom speed with 20× L IS Lens (from wide-angle to telephoto):

CONSTANT: Level 1: approx. 60 seconds  
Level 16: approx. 3.5 seconds

VARIABLE: Up to approx. 10 seconds

Zoom speed varies depending on the lens.

### Zoom lever on the carrying handle:

You can select the zoom speed from low, middle and high.

**MENU**  
( 24)

CAMERA SETUP



ZOOM HANDLE · MIDDLE

Open the menu and select [CAMERA SETUP]. Select [ZOOM HANDLE], select the zoom speed and close the menu.

**Zoom ring:**

The zoom speed is linked to the speed you turn the zoom ring.

**Zoom buttons on the wireless controller:**

The zoom speed is constant and cannot be adjusted.

**Zoom Preset (Lenses Equipped with the Zoom Preset Function)**

This function enables any given zoom setting to be memorised and to return to the zoom setting instantly.

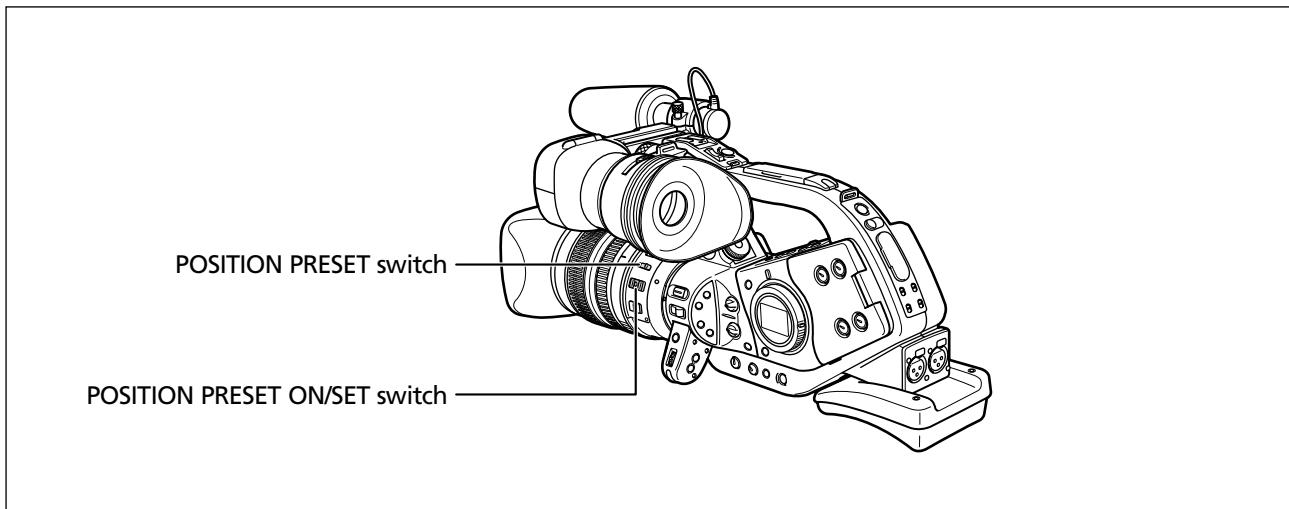
**Presetting the Zoom**

**1. Set the POSITION PRESET switch to ZOOM.**

**2. Move the POSITION PRESET ON/SET switch to SET.**

The preset zoom position appears in yellow on the zoom indicator.

**Returning to the Preset Zoom Position**

**Move the POSITION PRESET ON/SET switch to ON.**

The camcorder returns to the preset zoom position.



- The preset setting is cancelled when you attach the optional Extender XL 1.6x or mount a lens with different magnification.
- The camcorder uses the zoom speed of the CONSTANT setting when returning to the preset zoom position.

# Adjusting the Focus

---

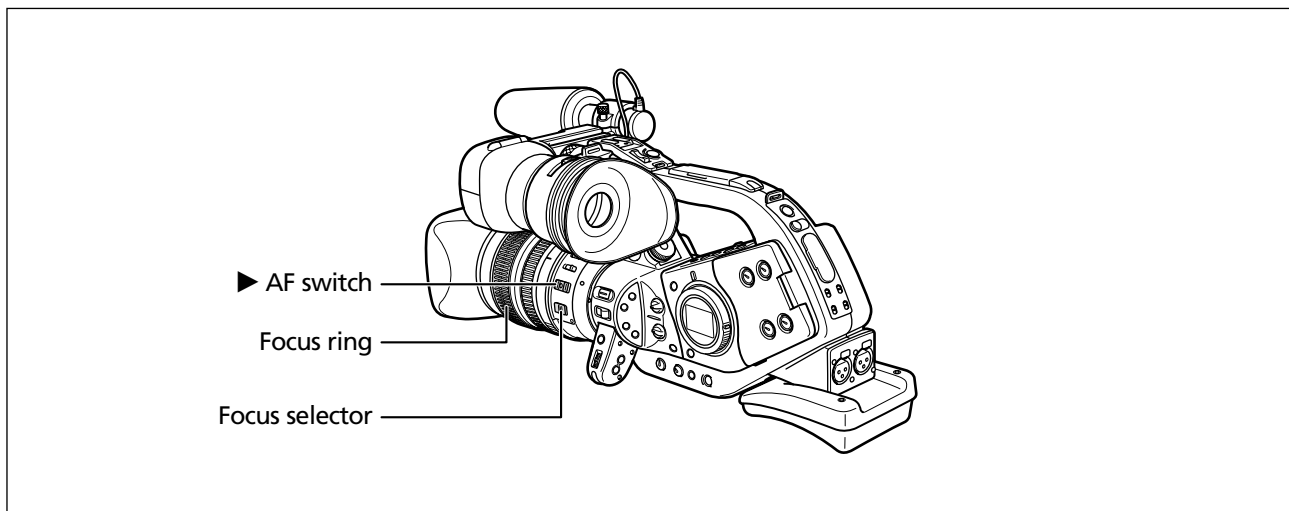

## Autofocus (Lenses Equipped with the Autofocus Function)

---

Autofocus is set when the focus selector on the lens is set to AF. The camcorder uses TTL autofocus system with a focusing range of 2 cm (at wide-angle from the front of the lens barrel) to  $\infty$ . The camcorder focuses on the subject in the centre of the screen.

### Temporary Focus Override

---

#### Turn the focus ring during autofocus to focus manually.

Autofocus will resume as soon as you take your hand away from the focus ring.



When recording under bright conditions, the camcorder sets a small aperture value, and the picture may appear blurred. This may be more noticeable at wide-angle. When you are using a lens with built-in ND filter, turn it on/off according to the screen display ( 41).



- When recording under dark conditions, the focusing range narrows and the picture may appear blurred.
- In 25p mode, autofocus takes longer than in the 50i mode.
- Autofocus may not work well on the following subjects. In such case, focus manually.
  - Reflective surfaces
  - Subjects with low contrast or without vertical lines
  - Fast moving subjects
  - Through dirty or wet windows
  - Night scenes

## Manual focus

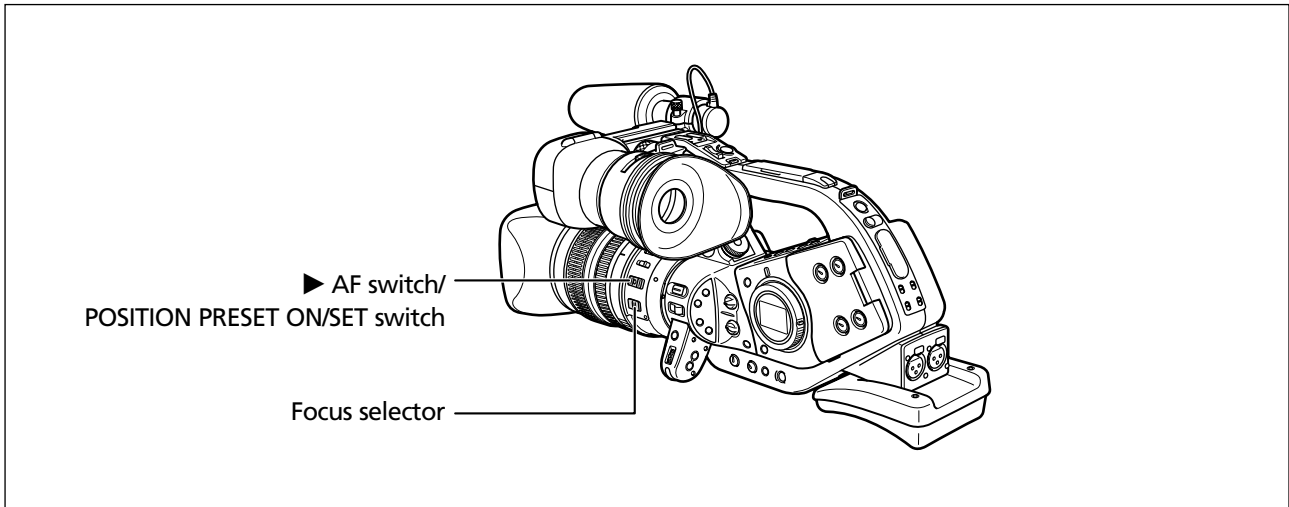

1. Lenses equipped with autofocus function: Slide the focus selector on the lens to **M**.
2. Zoom into telephoto.
3. Rotate the focus ring to adjust the focus.
4. Operate the zoom to reframe the subject.

If you focus manually then leave the camcorder with the power turned on, you may lose focus on your subject. This possible slight shift in focus is due to a rise in temperature in the camcorder interior and lens. Check the focus before resuming shooting.

### Temporary Autofocus

Press the ► **AF switch on the lens in the direction of AF and hold it.**

Autofocus is activated as long as you hold the ► AF switch.



When using the ► AF switch, make sure the POSITION PRESET switch is set to OFF.

## Focus Preset (Lenses Equipped with the Focus Preset Function)

---

This function enables a focus setting to be memorised and to return to the focus setting instantly. You can also select the speed with which the camcorder returns to the preset focus setting.

### Presetting the Focus

---



1. Set the focus selector to **M**.  
"MF" appears.
2. Set the **POSITION PRESET** switch to **FOCUS**.
3. Adjust the focus with the focus ring.
4. Move the **POSITION PRESET ON/SET** switch to **SET**.  
"MF" and the focus preset speed appear in yellow.

### Setting the Focus Preset Speed

---

#### **MENU**

( 24)

CAMERA SETUP



F SPEED PSET•HIGH

Open the menu and select [**CAMERA SETUP**]. Select [**F SPEED PSET**], select a setting option and close the menu.

The selected speed appears next to "MF".

### Returning to the Preset Focus Setting

---

Move the **POSITION PRESET ON/SET** switch to **ON**.

The camcorder returns to the preset focus setting.



The preset setting resets and sets to OFF when you turn the camcorder off or unmount the lens.



# Using the ND Filter (Lenses with Built-in ND Filter)

When recording under bright conditions, the camcorder sets a small aperture value, and the picture may appear blurred. When you are using a lens with built-in ND filter, turn it on/off according to the screen display.

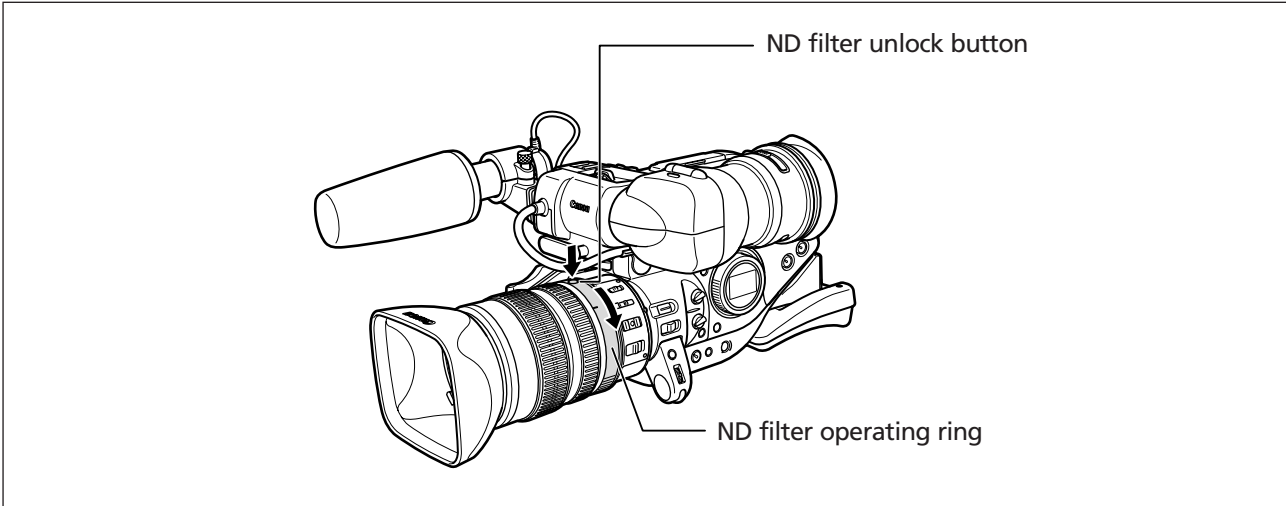

**With the 20× L IS Lens: Press the ND filter unlock button and turn the ND filter operating ring.**

When the camcorder is set to Easy Recording or Auto mode, following displays appear:

Screen display	What it means	What you should do
No display	ND filter is not activated	-
"ND" displayed	ND filter is activated	-
"ND <b>ON</b> " flashes	ND filter required	Turn on the ND filter
ND " <b>ON</b> " flashes	Lenses with ND filter on/off: External ND filter required Lenses with selectable ND filter density: Higher density or external ND filter required	Select a higher density built-in ND filter or attach an external ND filter to the lens*
ND " <b>OFF</b> " flashes	Built-in ND filter not required	Turn off the ND filter

\* If you have no external ND filter available, use the Tv mode and set a high shutter speed, or use the Av mode and set a small aperture value.



- Turning on/off the ND filter changes the aperture setting. Readjust the aperture in Av mode as required.
- Depending on the scene, the colour may change when turning on/off the ND filter. In such case, setting a custom white balance may be effective.

# Selecting the Frame Rate

Select between standard 50i and 25p.

## 50i Mode

Records in 50 fps interlace mode, same as TV signals.

## 25p Mode

Records in 25 fps progressive mode and outputs signals converted into 50 fps interlace.

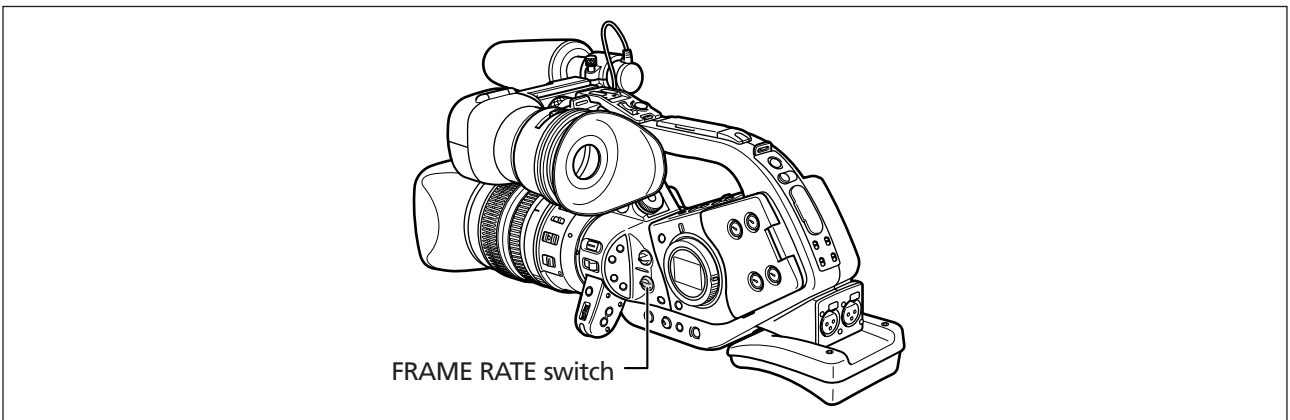
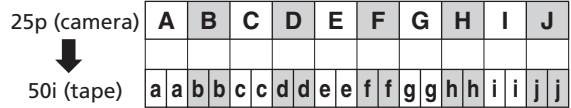

**Set the FRAME RATE switch to the desired position.**

The selected frame rate appears.



The frame rate does not change when you operate the FRAME RATE switch during recording. It changes once you pause recording.

# Recording in 16:9 Mode

The camcorder uses the full width of the CCD, retaining image quality and providing a larger horizontal angle of view.

E

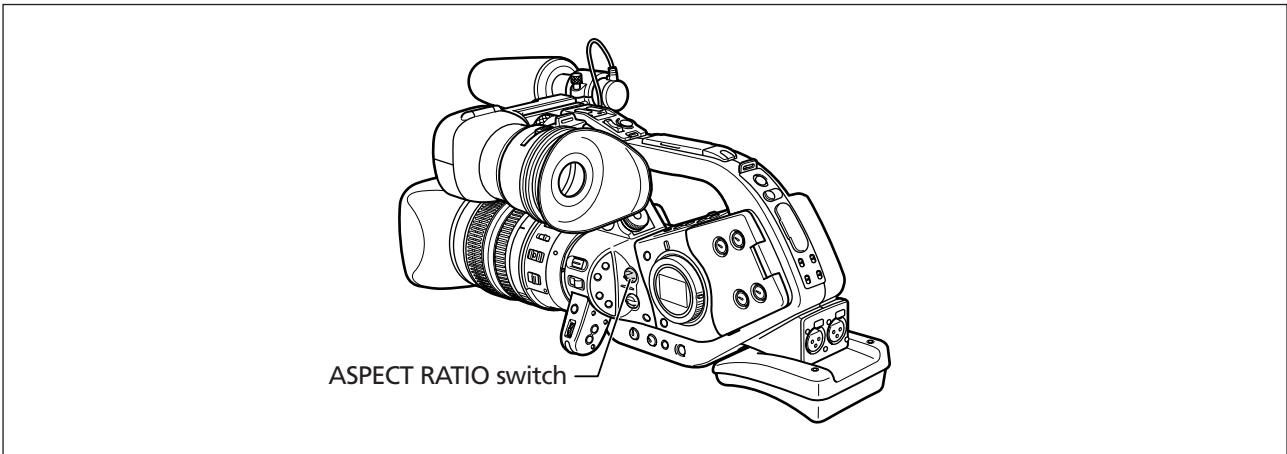

## Set the ASPECT RATIO switch to 16:9.

The screen changes to the "letterbox" format.



- If you play back a 16:9 recording on a normal TV, the image appears horizontally squeezed.
- The aspect ratio does not change when you operate the ASPECT RATIO switch during recording. It changes once you pause recording.

Recording

# Setting the Time Code

---

## Selecting the Run Options

---

You can select from record run (REC-RUN), record run preset (REC-RUN PS.) and free-run (FREE-RUN) time code. With record run, the time code runs only when you are recording. With free run, the time code runs regardless of the operation of the camcorder. With record run preset and free-run, you can select the starting point.

Normally select record-run. Select free-run time code when you wish to record with multiple camcorders set to the same time code.



### MENU

( 24)

TIME CODE



COUNT-UP . . . . . REC-RUN

1. Open the menu and select [TIME CODE]. Select [COUNT-UP] and set it to [REC-RUN], [REC-RUN PS.] or [FREE-RUN].

When you selected [REC-RUN]: Close the menu.

When you selected [REC-RUN PS.] or [FREE-RUN]: The starting point set/reset options appear.

**When you selected [REC-RUN PS.] or [FREE-RUN]:**

2. Select [SET].

The hours display flashes.

3. Turn the SET dial to select the hour and press the SET dial.

- The next part of the display starts flashing.
- Set the minutes, seconds and frames in the same way.

4. Close the menu.



- When setting the free-run time code, the time code starts to run when you press the MENU button in the middle of the setting, or when you press the SET dial after setting the last digits.
- To reset the time code to [00:00:00:00], select [RESET] in step 2.
- When recording over existing scenes: When a time code discontinuity occurred near the recording start point, the time code at recording start may be discontinuous.
- When the backup battery is installed, the free-run time code continues to run even when you disconnect the battery pack.

## Setting the User Bit

The user bit display works on the hexadecimal system that consists of a mixture of eight numbers or letters. There are sixteen possible characters, numbers 0 to 9 and letters A to F. This is useful for labeling tapes.



### MENU

( 24)

VCR SETUP

▶▶ USR BIT DATA·SET

#### 1. Open the menu and select [VCR SETUP] and [USR BIT DATA].

The user bit set/reset options appear.

#### 2. Select [SET].

The first part of the display flashes.

#### 3. Turn the SET dial to select the number/alphabet and press the SET dial.

- The next part of the display starts flashing.
- Set the rest of the display in the same way.

#### 4. Close the menu.



To reset the user bit to [00 00 00 00], select [CLEAR] in step 2.

User bit can be recorded when recording with the camcorder or from analog devices. The user bit of your camcorder cannot be recorded when recording from digital devices.

## Displaying the User Bit



### MENU

( 24)

DISPLAY SETUP/

▶▶ USR BIT DISP·OFF

Open the menu and select [DISPLAY SETUP/ ]. Select [USR BIT DISP], set it to [ON] and close the menu.



User bit cannot be displayed during special playback.

# Audio Recording

You can set the audio mode to 16 bit or 12 bit. With 12 bit, you can select to record on two channels, leaving two channels free for adding sound later (12bit CH  $\frac{1}{2}$ ), or to record on four channels simultaneously (12bit CH  $\frac{1}{2}$ ,  $\frac{3}{4}$ ).

The sampling frequency in 16 bit is 48 kHz and in 12 bit 32 kHz. The 16 bit mode provides higher sound quality.

Audio dubbing cannot be performed with this camcorder.

## 16bit

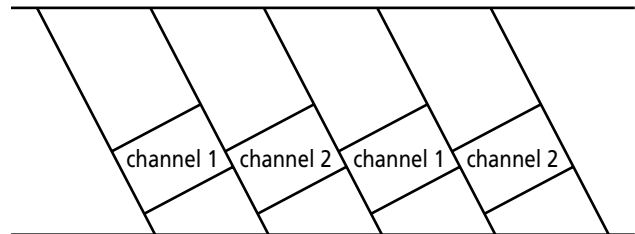

## 12bit CH $\frac{1}{2}$

The channels next to channel 1 and 2 will not be used.

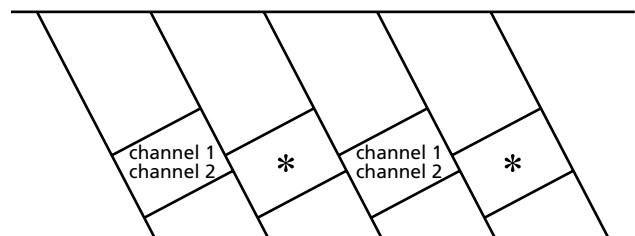

## 12bit CH $\frac{1}{2}$ , $\frac{3}{4}$

The channels 1, 2, 3 and 4 will be recorded simultaneously.

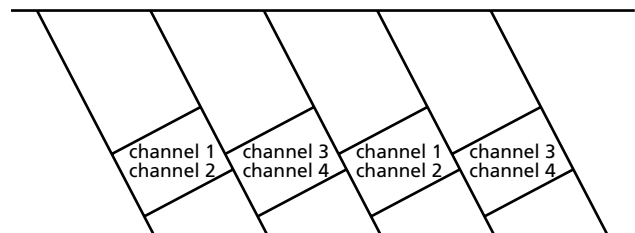

## Selecting the Audio Mode (16bit, 12bit CH $\frac{1}{2}$ , 12bit CH $\frac{1}{2}$ , $\frac{3}{4}$ )



**MENU**  
( 24 )

AUDIO SETUP

AUDIO MODE...16bit

Open the menu and select [AUDIO SETUP]. Select [AUDIO MODE], select a setting option and close the menu.

## Recording on Channels 1 and 2

Select the audio input from FRONT MIC (supplied microphone unit), AUDIO1 (RCA terminals) or REAR (XLR terminals). Refer also to the audio block diagram ( 120).

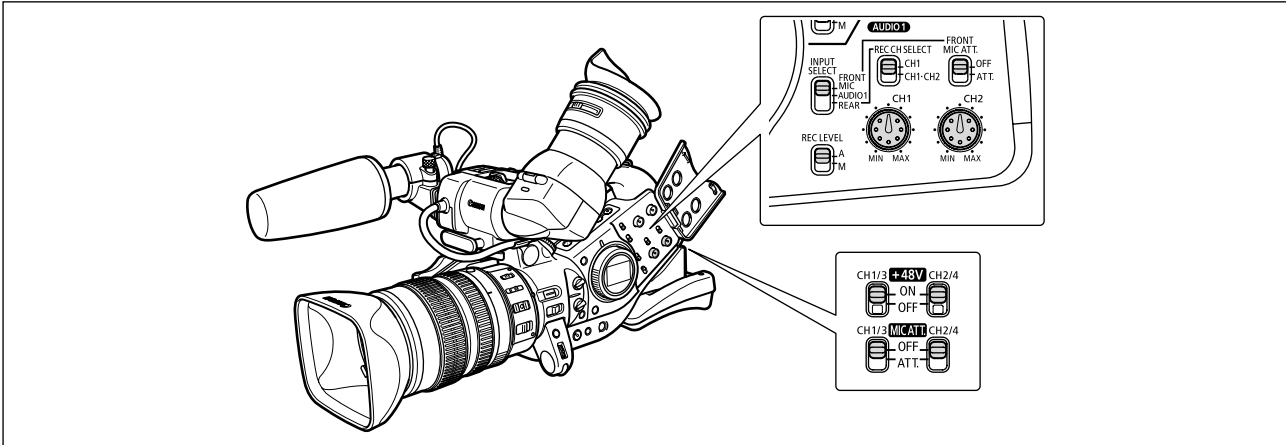

### When Using the Front Microphone

#### Set the INPUT SELECT switch to FRONT MIC.

Turn on the microphone attenuator (20 dB) as necessary by setting the FRONT MIC ATT. switch to ATT.

### When Connecting to the RCA terminals of AUDIO1 (Line-in Recording)

1. Connect the device to the RCA terminals of AUDIO1.
2. Set the INPUT SELECT switch to AUDIO1.

### When Connecting to the XLR terminals

#### 1. Connect a microphone to the XLR terminals.

To supply a microphone with phantom power, set the +48V switch to ON. Make sure to connect the microphone first, before turning on the phantom power. Keep the microphone connected when turning off the phantom power.

2. Set the INPUT SELECT switch to REAR.
3. Set the REC CH SELECT switch to CH1 or CH1-CH2.

Input terminal	Position of the REC CH SELECT switch	Recorded channel
CH1/3	CH1	Channel 1
	CH1-CH2	Channel 1+Channel 2
CH2/4	CH1	Channel 2
	CH1-CH2	---

4. Turn on the microphone attenuator (20 dB) as necessary by setting the MIC ATT. switch to ATT.
5. For 12dB gain-up: Open the menu and select [AUDIO SETUP]. Select [R-XLR GAINUP], set it to [12dB] and close the menu.



When connecting a microphone not supporting phantom power, make sure to set the +48V switch to OFF. Otherwise the microphone may be damaged.

## Recording on Channels 3 and 4

Select the audio input from SHOE (optional MA-300 Microphone Adapter), AUDIO2 (RCA terminals) or REAR (XLR terminals). Refer also to the audio block diagram (120).

Make sure to set [AUDIO MODE] to [12bit CH 1/2, 3/4].

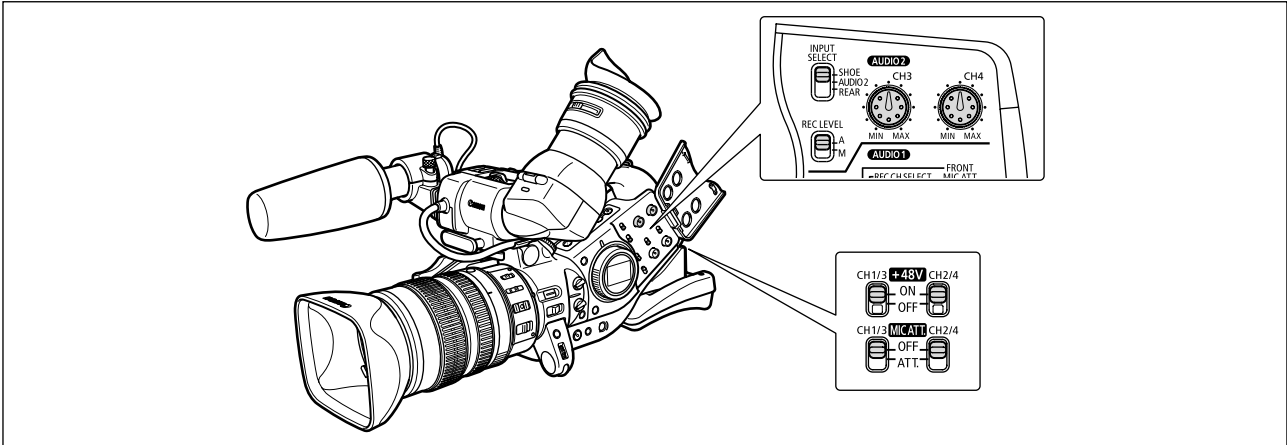

### When Connecting to the Advanced Accessory Shoe

#### 1. Attach the optional MA-300 Microphone Adapter to the advanced accessory shoe.

- With the MA-300, you can use balanced microphones on all 4 channels.
- Refer also to the MA-300 instruction manual.

#### 2. Set the INPUT SELECT switch to SHOE.



- Phantom power cannot be used with the MA-300.
- MA-100 and MA-200 cannot be used.

### When Connecting to the RCA terminals of AUDIO2 (Line-in Recording)

#### 1. Connect the device to the RCA terminals of AUDIO2.

#### 2. Set the INPUT SELECT switch to AUDIO2.

### When Connecting to the XLR terminals

#### 1. Connect a microphone to the XLR terminals.

To supply a microphone with phantom power, set the +48V switch to ON. Make sure to connect the microphone first, before turning on the phantom power. Keep the microphone connected when turning off the phantom power.

#### 2. Set the INPUT SELECT switch to REAR.

#### 3. Turn on the microphone attenuator (20 dB) as necessary by setting the MIC ATT. switch to ATT.

#### 4. For 12 dB gain-up: Open the menu and select [AUDIO SETUP]. Select [R-XLR GAINUP], set it to [12dB] and close the menu.





When connecting a microphone not supporting phantom power, make sure to set the +48V switch to OFF. Otherwise the microphone may be damaged.

## Adjusting the Audio Recording Level

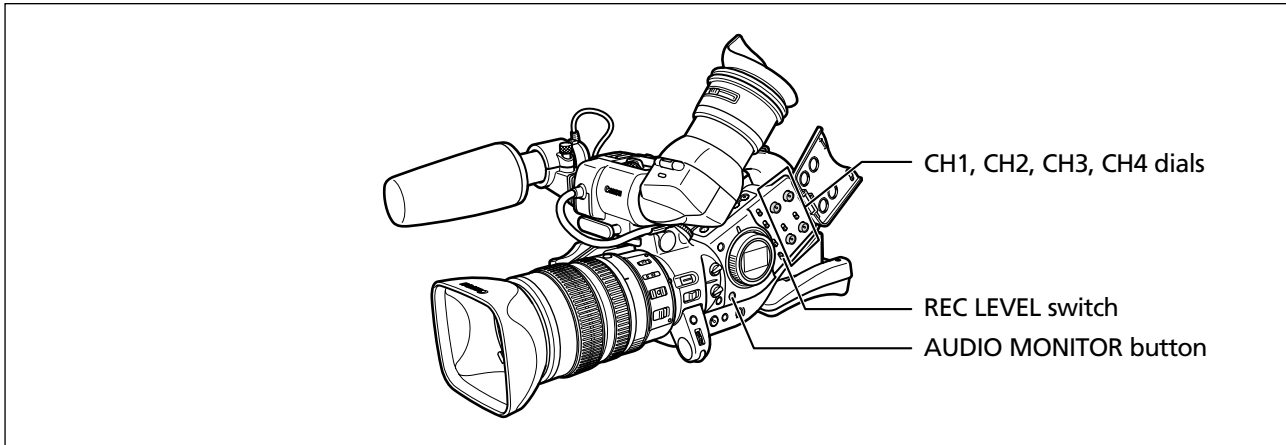

### Hiding/Displaying the Audio Level Indicator on the Screen

**MENU**  
( 24)

DISPLAY SETUP/



AUDIO LEVEL...ON

Open the menu and select [DISPLAY SETUP/ ]. Select [AUDIO LEVEL], select a setting option and close the menu.

The audio level indicator can also be turned on/off with the custom key ( 70).

### Automatic Audio Adjustments

Set the REC LEVEL switch to A.

### Manual Audio Adjustments

1. Set the REC LEVEL switch to M.
2. When recording on 4 channels, press the AUDIO MONITOR button and select CH1/2 or CH3/4.

The setting changes with each press of the button in the order of CH1/2, CH3/4, CH1+3/2+4. Do not select CH1+3/2+4 when adjusting the level.

3. Turn the respective CH1, CH2, CH3 or CH4 dial to adjust the audio level.



- We recommend using headphones when adjusting the audio level. If the input level is too high, audio may become distorted even if the audio level indicator is displaying an appropriate level.
- You can select to synchronise the audio signal with the video signal by adding an equal amount of delay to the audio. Open the menu and select [AUDIO SETUP]. Select [AUD.M.SET], set it to [LINE OUT] and close the menu. If you wish to monitor audio in real time, select [NORMAL]. In either setting, audio and video signals will be recorded synchronised on a tape.

## Image Stabilizer (Lenses Equipped with Image Stabilizer)

The image stabilizer can be turned off.

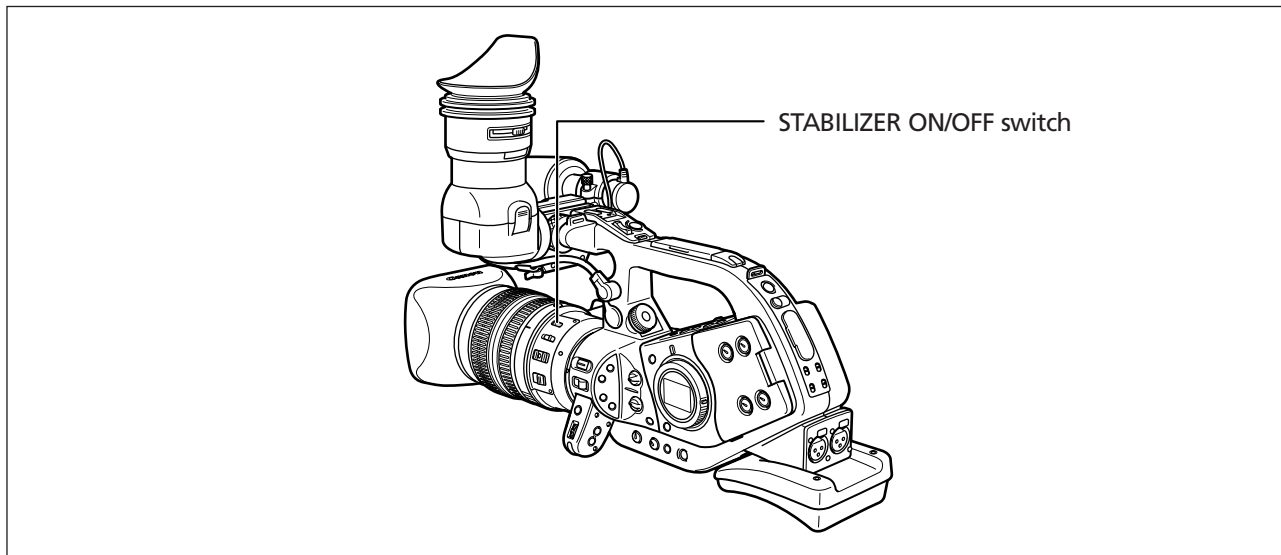

**Move the STABILIZER ON/OFF switch to OFF.**



- The image stabilizer cannot be turned off in the Easy Recording mode.
- The image stabilizer is designed to compensate a normal degree of camcorder shake.
- The image stabilizer may not be effective when attaching an optional Extender.
- We recommend turning off the image stabilizer when mounting the camcorder on a tripod.

# Using the Programmed AE Modes

Programmed auto exposure modes provide automated advanced recording techniques ensuring professional results in various shooting conditions.

E

## Selecting the Programmed AE Modes

Press the button and turn the POWER dial.

The symbol of the selected mode appears.

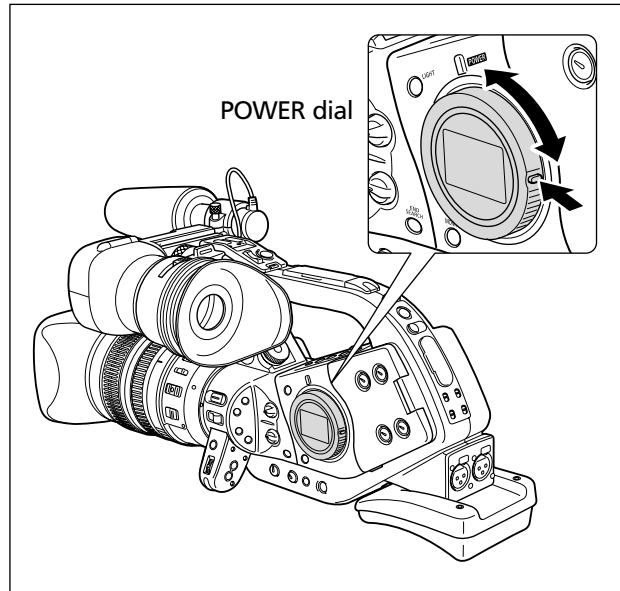

Do not change the mode during recording as the brightness of the image may change abruptly.

### **A** Auto

Like the Easy Recording mode, the camcorder automatically controls camera adjustments allowing you to simply point and shoot. However, in the Auto mode, you have the option of adjusting the settings manually.

### **Tv** Shutter-Priority ( 54)

Use this mode to select the shutter speed. The camcorder automatically sets a matching aperture setting.

### **Av** Aperture-Priority ( 55)

Use this mode to select between 7 aperture settings - from f/1.6 to f/11 (or to full iris close) - and the camcorder automatically sets a matching shutter speed. This mode allows for the best control of depth of field.



Recording

## **M** Manual (📖 56)

This mode offers the creative freedom of a complete range of manual controls. In the Manual mode, options exist to set the exposure at any combination of shutter speed and aperture levels.



## **🔦** Spotlight

The Spotlight mode automatically adjusts the exposure to effectively record images and/or subjects lit by a spotlight or other concentrated light source.



## **🔥** Low Light

This mode allows you to continue recording even when light levels begin to fall. The Low Light mode selects lower shutter speeds (50i: 1/6-1/49, 25p: 1/6-1/24) to deliver proper exposure.

- Moving subjects may leave a trailing afterimage.
- Picture quality may not be as good as in other modes.
- White points may appear on the screen.
- Autofocus may not work as well as in other modes. In such case, adjust the focus manually.









## **☐** Easy Recording

The camcorder automatically controls focus, shutter speed, aperture, gain, white balance, and AE Shift allowing you to simply point and shoot. This mode locks all of these features and options, making them fixed and unadjustable.



### Availability of functions in each recording program.

Recording programs							
EXP. LOCK button	×		○		×	×	×
IRIS dial	×	× *1	× *1	○	○	×	×
SHUTTER button	×	× *1	○	× *1	○	×	×
AE SHIFT dial	× (0)		○ *2		×	×	× (0)
GAIN dial	× (auto)		○			× (0 dB)	× (auto)
WHITE BALANCE dial	× (auto)				○		
Custom preset adjustments	×				○		
CUSTOM PRESET SELECT button	×				○		
CUSTOM PRESET ON/OFF button	×				○		
Skin detail	×				○		
Frequency selection of Clear Scan	×	×	○ *3	×	○ *3	×	×
Clear Scan	×	×	○ *2	×	○	×	×



○: Available ×: Not available

\*1: Available when the exposure is locked.

\*2: Not available when exposure is locked.

\*3: Available during clear scan.

### 20× L IS, 16× IS II and 3× zoom lens

Recording program		Modes other than 
Manual focus ring		○
Zoom ring		○
Image Stabilizer*	× (on)	○
ND filter		○
Focus mode	× (autofocus)	○
▶AF switch/PUSH AF button	×	○

\* Not available with the 3× zoom lens.

# Recording in the Shutter-Priority (Tv) Mode

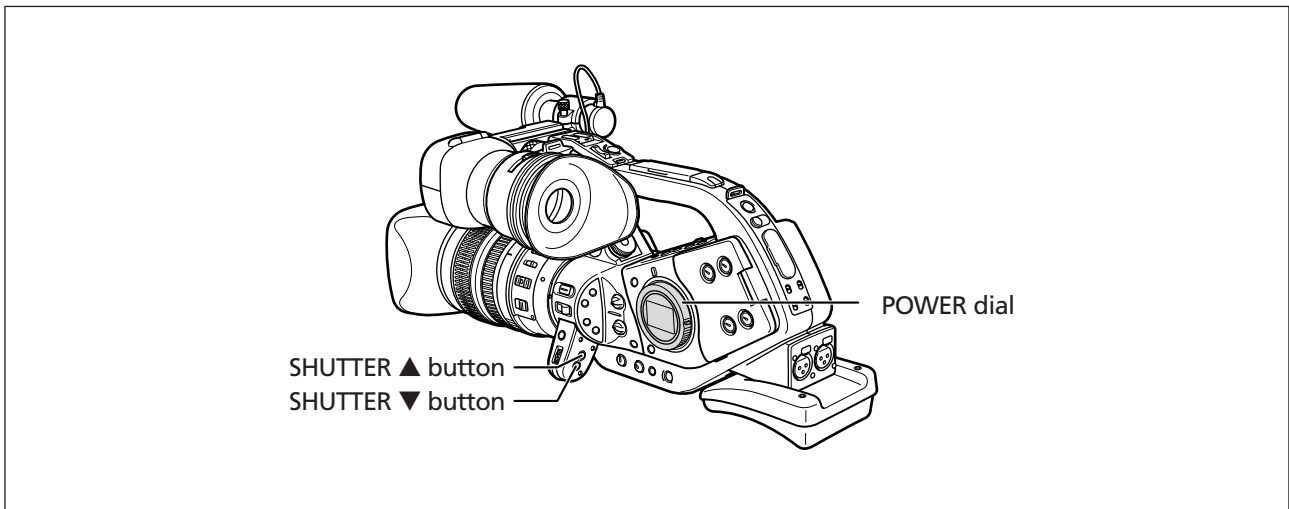

## Available shutter speeds:

1/6, 1/12, 1/25, 1/50, 1/120, 1/250, 1/500, 1/1000, 1/2000, 1/4000, 1/8000, 1/16000, CS (clear scan)



**1. Set the POWER dial to Tv.**

**2. Select the shutter speed with the SHUTTER ▲ or ▼ button.**



- Other settings such as aperture are set automatically.
- The shutter speed changes when you lock and change the exposure.
- When the gain is set to automatic, the shutter speed number flashes on the screen when the selected shutter speed is too high or too low for the recording condition. In such case, readjust the shutter speed. If you are using a ND filter, turn it off first and readjust the shutter speed.
- The image quality may decrease to some extent when using slow shutter speeds.
- Autofocus may not work when using slow shutter speeds.

# Recording in the Aperture-Priority (Av) Mode

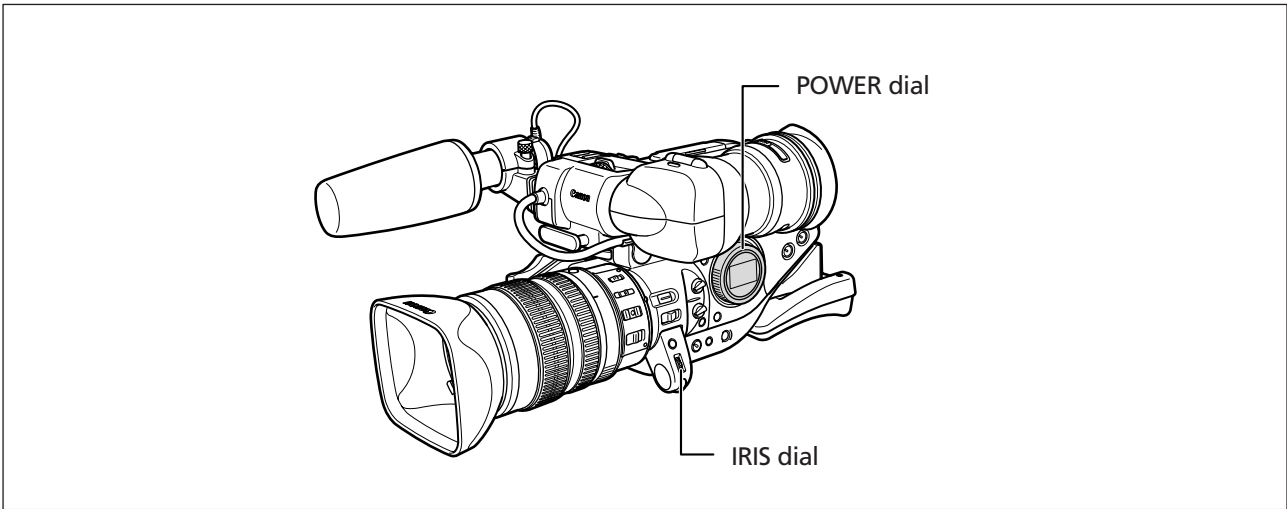

E

## Available aperture values (with 20× L IS lens):

F1.6, F2.0, F2.8, F4.0, F5.6, F8.0, F11, CLOSE



1. Set the POWER dial to Av.
2. Select the aperture with the IRIS dial.



- Other settings such as shutter speed are set automatically.
- The aperture changes when you lock and change the exposure.
- When the gain is set to automatic, the aperture number flashes on the screen when the selected aperture is not appropriate for the recording condition. In such case, readjust the aperture.
- When the built-in ND filter of a lens is activated, the picture may become dark when you set a high F number. In such case, turn the ND Filter off first and readjust the aperture.

Recording

# Recording in the Manual Mode

You can set the exposure at any combination of shutter speed and aperture levels.

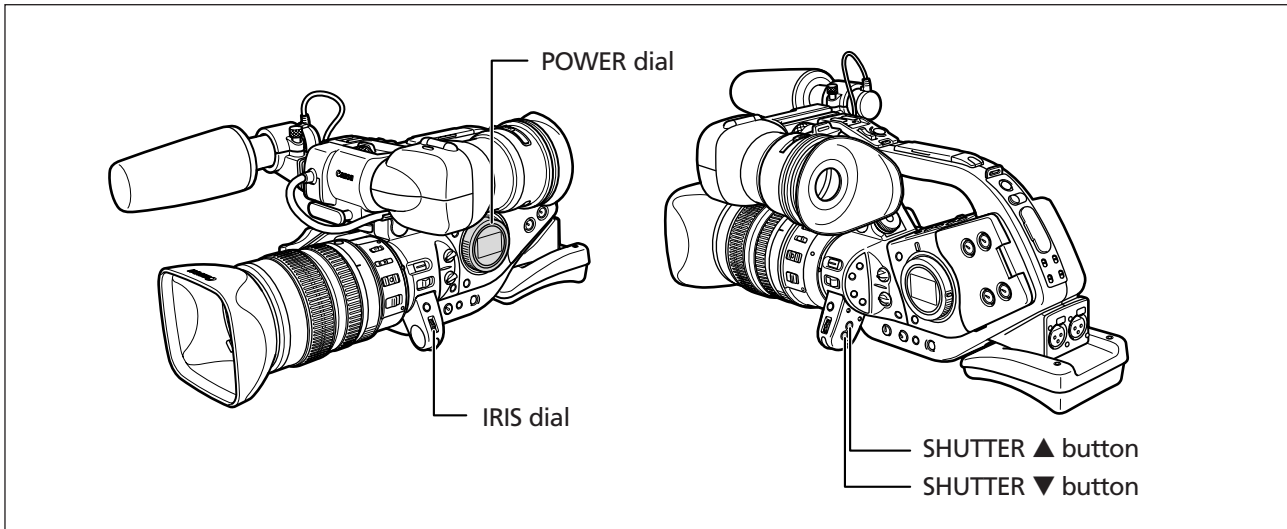

## Available settings

Shutter speed	1/6, 1/12, 1/25, 1/50, 1/60, 1/75, 1/90, 1/100, 1/120, 1/150, 1/180, 1/210, 1/250, 1/300, 1/350, 1/400, 1/500, 1/600, 1/700, 1/800, 1/1000, 1/1200, 1/1400, 1/1600, 1/2000, 1/2400, 1/2800, 1/3200, 1/4000, 1/8000, 1/16000, CS (clear scan)
Aperture (with 20× L IS lens)	F1.6, F1.8, F2.0, F2.2, F2.4, F2.6, F2.8, F3.2, F3.4, F3.7, F4.0, F4.4, F4.8, F5.2, F5.6, F6.2, F6.7, F7.3, F8.0, F8.7, F9.5, F10, F11, CLOSE



### 1. Set the POWER dial to M.

The exposure indicator appears.

### 2. Select the aperture with the IRIS dial.

### 3. Select the shutter speed with the SHUTTER ▲ or ▼ button.



# Adjusting the Exposure

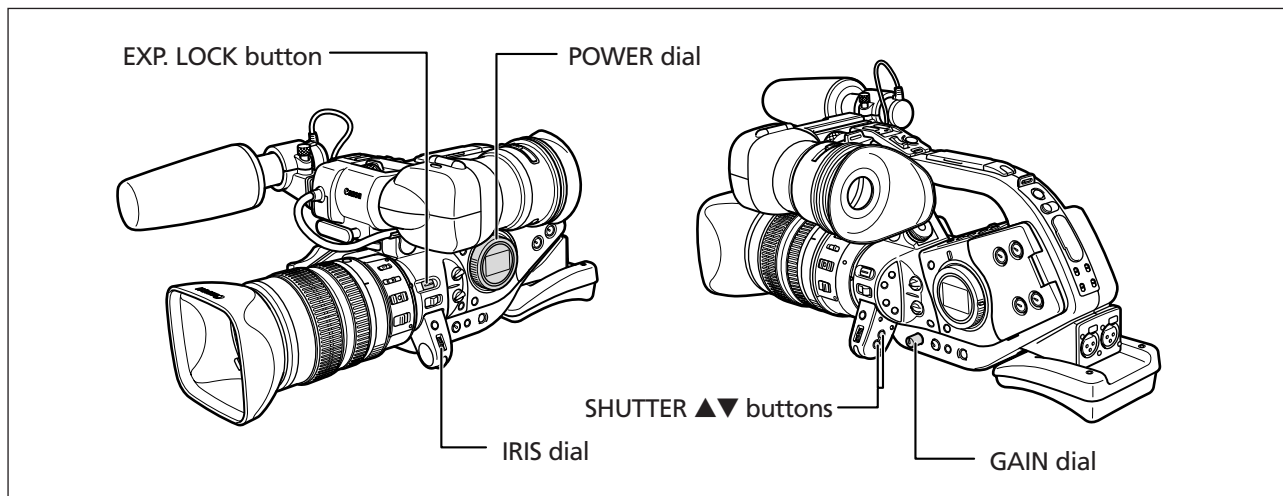

## Exposure Lock



1. Set the POWER dial to **A**, **Tv** or **Av**.

2. Press the EXP. LOCK button.

The exposure indicator appears.

## Changing the Aperture after Exposure Lock

You can select from 23 aperture settings (with 20× L IS lens). The setting can be adjusted in 1/4 steps. However, only the following numbers are displayed on the screen: F1.6, F2.0, F2.8, F4.0, F5.6, F8.0, F11, CLOSE.

Select the aperture with the IRIS dial.

## Changing the Shutter Speed after Exposure Lock

You can select from 12 shutter speeds (with 20× L IS lens).

Select the shutter speed with the SHUTTER ▲ or ▼ button.

## Changing the Gain after Exposure Lock

You can select from 6 gain levels .

1. Press the GAIN dial so that it pops out.

2. Turn the GAIN dial to adjust the level.

The selected level appears.



+18 dB is not available in 25p mode. When you select +18 dB, it automatically sets to +12 dB ("12dB" appears in yellow).

# Using AE Shift

You can use the AE Shift control to manually override the automatic exposure system to darken or lighten the image. Select from 13 AE levels (+2.0, +1.5, +1.0, +0.75, +0.5, +0.25,  $\pm 0$ , -0.25, -0.5, -0.75, -1.0, -1.5, -2.0).

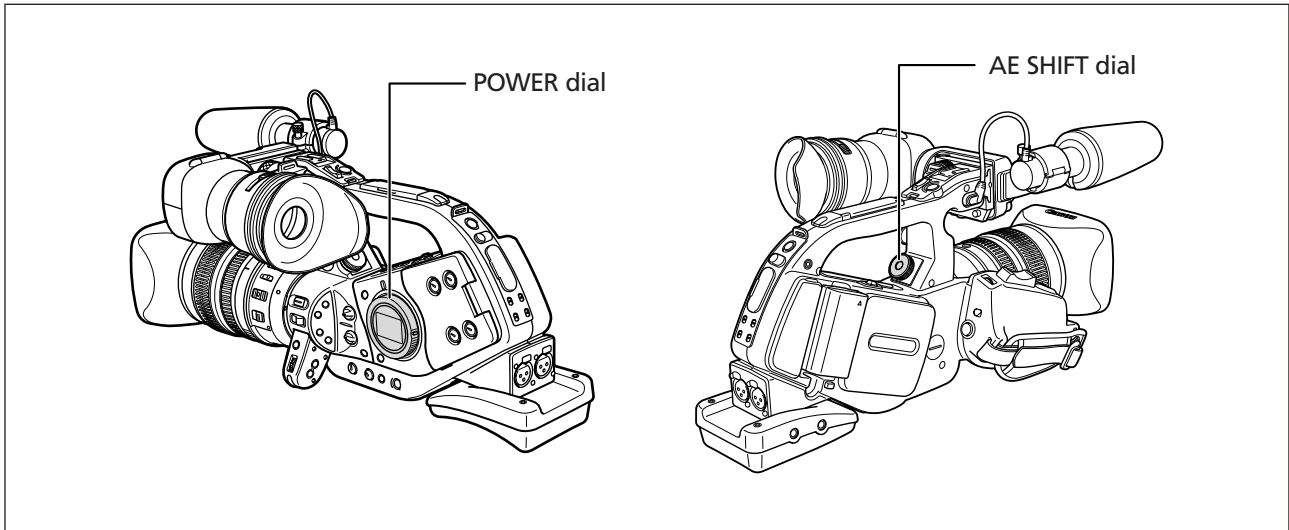

1. Set the POWER dial to **A**, **Tv** or **Av**.
2. Turn the AE SHIFT dial to adjust the level.  
The selected level appears.

## Adjusting the Gain

Gain control adjusts the amount of video signal generated depending upon lighting and shooting conditions. You can select from automatic gain control and preset levels that range from -3 to +18 dB.

-3 dB	For lowest noise recording for indoor, low light or low contrast scenes.
Auto	Automatic adjustment of gain.
0 dB	Life like night/artificial light scenes.
+3 dB/+6 dB/ +12 dB/+18 dB*	Increases brightness in indoor or low-light scenes. Increases depth of field.

\* +18 dB is not available in 25p mode. When you select +18 dB, it automatically sets to +12 dB ("12dB" appears in yellow).

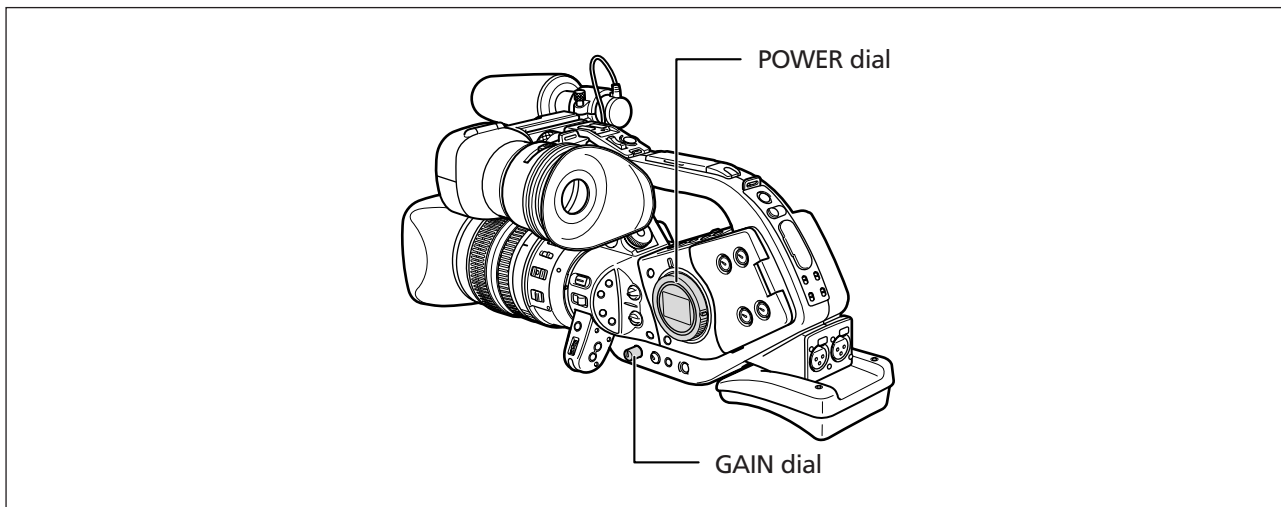

1. Set the POWER dial to **A**, **Tv**, **Av** or **M**.
2. Press the GAIN dial so that it pops out.
3. Turn the GAIN dial to adjust the level.

The selected level appears.



Noise may appear on the picture when setting a high gain level.

# Setting the White Balance

The camcorder uses an electronic white balance process to calibrate the picture for accurate colour display in different lighting conditions (i.e. sunlight versus indoor incandescent.)

Automated white balance settings include a fully automated mode, an indoor mode and an outdoor mode. In addition, you can set the white balance manually and save up to three white balance presets that can be reused for non-sequential shooting.

Auto	Automated adjustments of white balance.
☀ (Outdoor)	Bright sunlight - 5600°K
💡 (Indoor)	Incandescent light - 3200°K
Preset 1, 2, 3	Custom white balance setting variable 3200 - 5600°K.

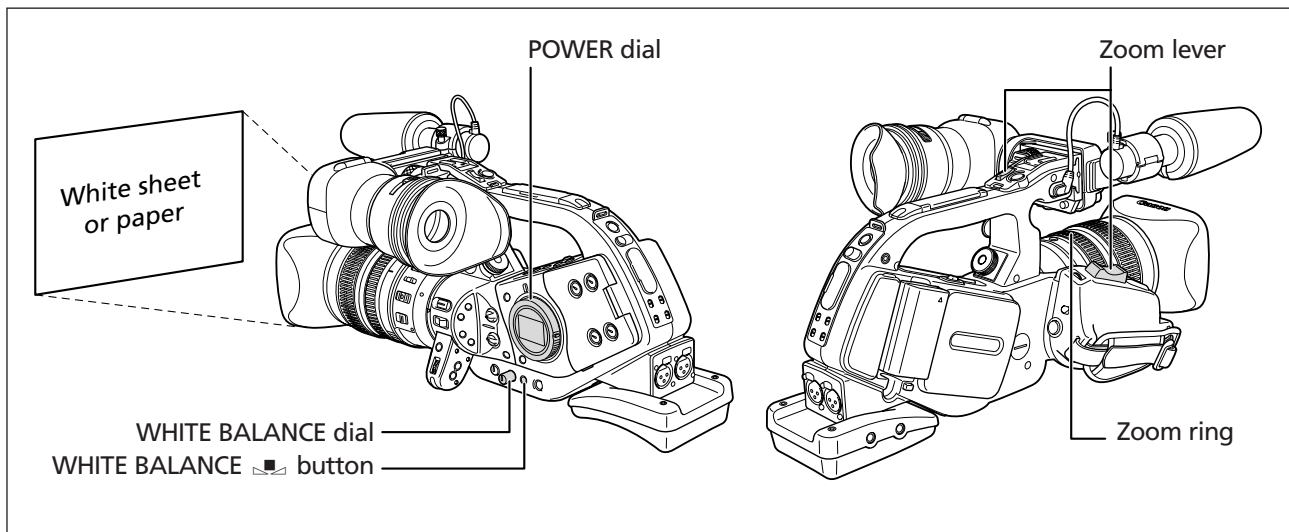



## Selecting an Automated White Balance Setting



1. Press the **WHITE BALANCE** dial so that it pops out.
2. Set the **WHITE BALANCE** dial to **A**, ☀ or 💡.

## Setting a Custom White Balance



1. Press the **WHITE BALANCE** dial so that it pops out.
2. Set the **WHITE BALANCE** dial to 1, 2 or 3.
3. Point the camcorder at a white object and zoom in until it fills the whole screen.  
Keep the camcorder zoomed at the white object until step 4 is completed.
4. Press the **WHITE BALANCE**  button.  
"  " flashes and stops flashing when setting is complete.



- The camcorder retains the custom white balance setting even if you turn it off.
- When you have set the custom white balance:
  - Depending on the light source, "  " may keep flashing. The result will still be better than with the auto setting.
  - When you have turned on/off the built-in ND-filter of the lens, reset the custom white balance.
- Custom white balance may provide better results in the following cases:
  - Changing lighting conditions
  - Close-ups
  - Subjects in a single colour (sky, sea or forest)
  - Under mercury lamps or certain types of fluorescent lights

## Recording with Preset Custom White Balance



1. Set the **POWER** dial to a recording program other than .
2. Turn the **WHITE BALANCE** dial to select a preset number.  
The preset custom white balance is activated.



- The custom preset settings [R GAIN], [G GAIN] and [B GAIN] ( 65) will override the white balance setting set with above procedure.

# Using the Zebra Pattern

This camcorder has a zebra pattern feature that shows black and white diagonal stripes over the area that is overexposed. The zebra pattern is only displayed on the screen. Use this feature to guide the adjustment of the aperture and shutter speed. Available zebra pattern settings: 80 IRE, 85 IRE, 90 IRE, 95 IRE, and 100 IRE.

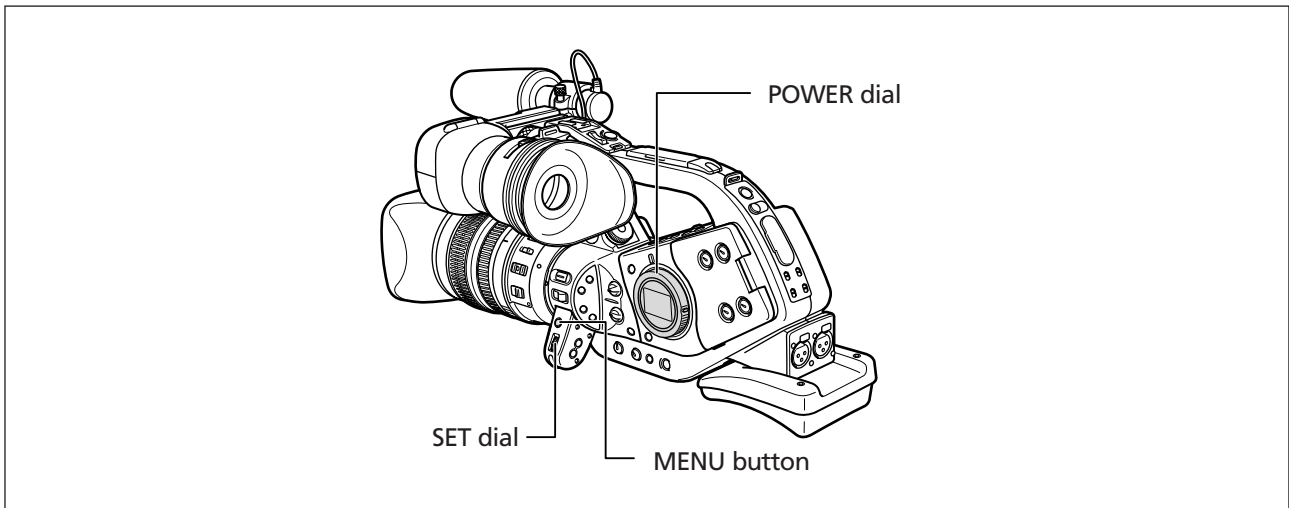

## Selecting the Zebra Pattern Level

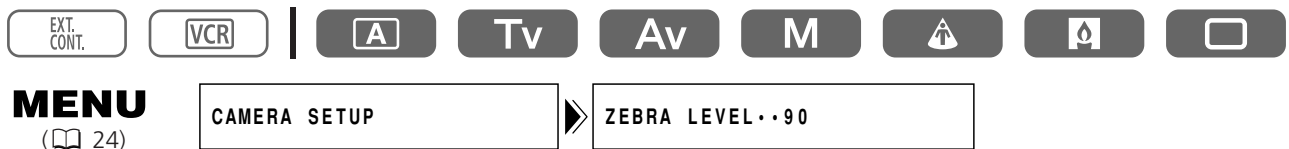

Open the menu and select [CAMERA SETUP]. Select [ZEBRA LEVEL], select a setting option and close the menu.

## Activating the Zebra Pattern

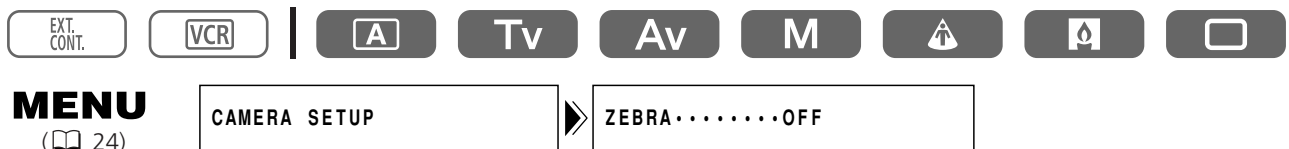

Open the menu and select [CAMERA SETUP]. Select [ZEBRA], set it to [ON] and close the menu.

# Using the Skin Detail Function

You can adjust hue, chroma, area and Y level to determine the skin area and soften the details to reduce the appearance of skin imperfections. A zebra pattern identifying the skin area appears, alternating with the normal picture (a white pattern appears on a connected TV or computer screen).

## Activating the Skin Detail Function



Open the menu and select [CAMERA SETUP] and [SKIN D.SET]. Select [SKIN DETAIL], set it to [HIGH], [MIDDLE] or [LOW] and close the menu.  
" " appears.

## Determining the Skin Area

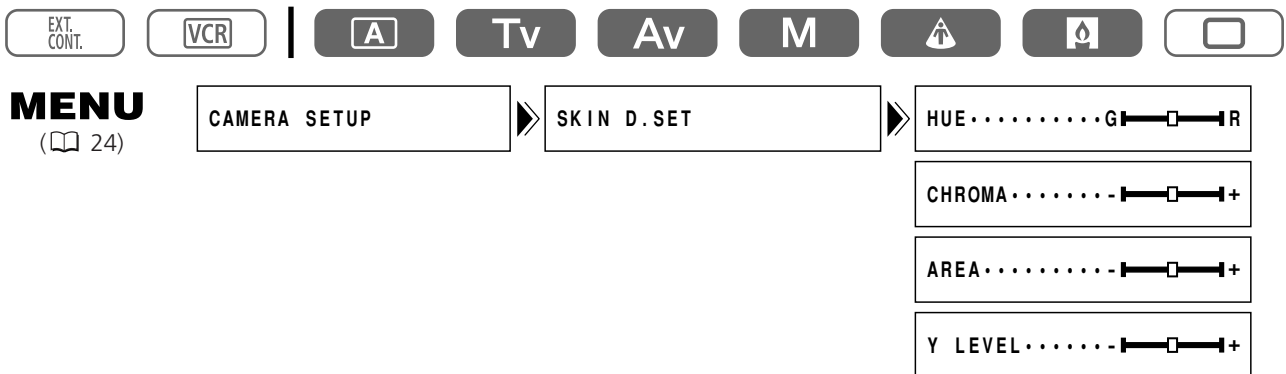

Open the menu and select [CAMERA SETUP] and [SKIN D.SET]. Select [HUE], [CHROMA], [AREA] or [Y LEVEL], adjust the levels and close the menu.

- HUE: Adjust the hue for detection of the skin area. Adjusting to [R] detects reddish skin colour, and to [G] detects greenish skin colour.
- CHROMA: Adjust the saturation for detection of the skin area. Adjusting to [+] detects brighter skin colour, and to [-] detects lighter skin colour.
- AREA: Adjust the colour range for detection of the skin area. Adjusting to [+] detects a wide colour range, and to [-] detects a narrow colour range.
- Y LEVEL: Adjust the brightness for detection of the skin area. Adjusting to [+] detects brighter skin colour, and to [-] detects darker skin colour.



You cannot record on the tape while determining the skin area.

# Using the Custom Preset

You can establish three preset registrations for the following 15 camera features: gamma curve, knee, black stretch/press, colour matrix, colour gain, colour phase, R gain, G gain, B gain, V detail, sharpness, coring, setup level, master pedestal and NR.

You can also import preset settings from another XL2 and save them to your camcorder.

## Gamma Curve

Select between standard gamma curve ([NORMAL]) and cine-like gamma curve ([CINE]).

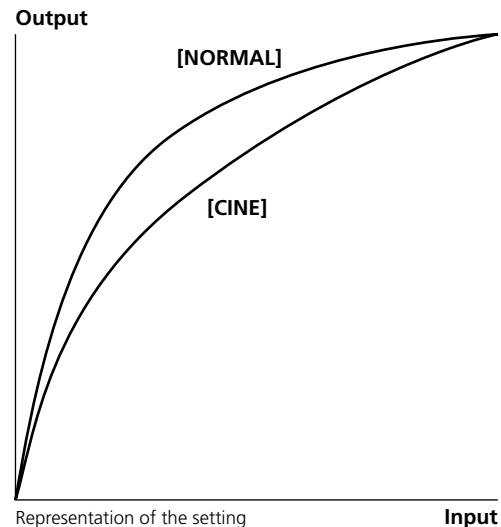

## Knee Point Adjustment

Adjust the dynamic range (knee point) in the highlight area of the image to prevent overexposure. You can select from [HIGH], [MIDDLE] or [LOW].

## Black Stretch/Black Press

Adjust the dynamic range in the black area of the image. You can select from [STRETCH], [MIDDLE] or [PRESS]. [STRETCH] emphasises contrast in the dark area, while [PRESS] enhances or deepens darkness.

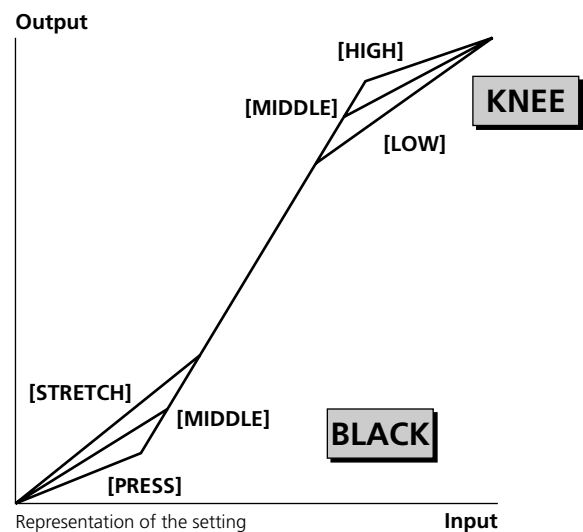

## Colour Matrix

Select from two colour matrix settings: [NORMAL] and [CINE]. Setting gamma and colour matrix to [CINE] creates cine-like colours.

## Colour Gain

Adjust the saturation of the colour from off (-) to oversaturated (+).



## **Colour Phase**

Adjust to [G] for adding more green to the image, and to [R] for more red.

## **R Gain**

Adjust to [-] for white balance toward cyan, and to [+] for white balance toward red.

## **G Gain**

Adjust to [-] for white balance toward magenta, and to [+] for white balance toward green.

## **B Gain**

Adjust to [-] for white balance toward yellow, and to [+] for white balance toward blue.

## **Vertical Detail**

Adjust the vertical detail frequency for recordings in 25p mode. Select from [NORMAL] and [LOW].

- When you play back a recording on an interlaced TV with [V DETAIL] set to [NORMAL], horizontal lines may flicker.
- Select [NORMAL] for non-interlaced playback or editing on a computer, or for transferring to a DVD.
- Image resolution will not change in the 50i mode.
- When you select a custom preset setting with [V DETAIL] set to [LOW] in 50i mode, "CP" appears in yellow.

## **Sharpness**

Adjust the degree of sharpness in the picture. Adjust to [-] for a softer picture, and to [+] for a sharper picture. When set to the [+] side, noise may become more noticeable.

## **Coring**

Adjust the detail noise level. Adjust to [-] to add the noise, and to [+] to reduce noise.

## **Setup Level**

Adjust the black level of the video signal. Adjust to [-] to darken the picture, and to [+] to brighten the shadow area.

## **Master Pedestal**

Adjust the master pedestal level. Adjust to [-] to make dark areas darker and increase the contrast, and to [+] to make dark areas lighter and reduce the contrast.

## **Noise Reduction**

Select the variable range of noise reduction from [OFF], [HIGH], [MIDDLE] and [LOW]. With [HIGH], [MIDDLE] and [LOW], the noise reduction level is adjusted according to the gain. Select [HIGH] for maximum variable range.

- When set to [HIGH], moving subjects may leave a trailing afterimage.
- When the noise based on the gain setting is low, the NR effect may not be noticeable.

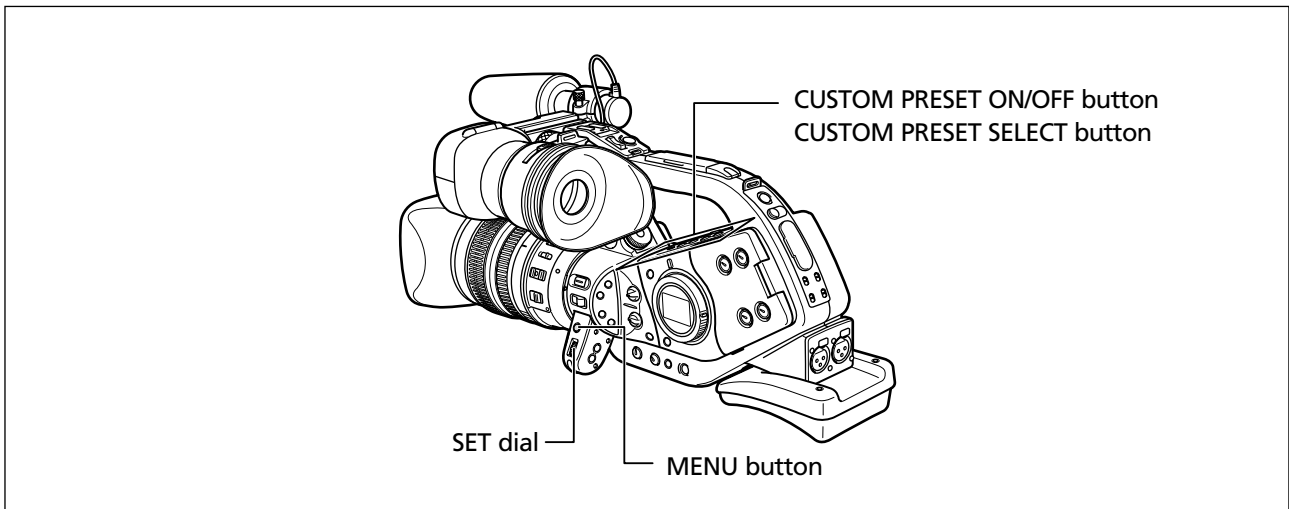

## Setting the Custom Preset Settings



1. Open the menu and select [CUSTOM PRESET].
2. Select [PRESET SETUP].  
The custom preset items appear.
3. Select [SEL PRESET] and select the custom preset file you wish to change.
4. Select the preset items, select the setting options and close the menu.



- The custom preset menu consists of 5 pages. The items [SEL PRESET] and [ON/CLEAR] can be selected on each page.
- When you attempt to change a protected setting, "ON" starts flashing.

## Protecting a Custom Preset File

Open the menu and select [CUSTOM PRESET], followed by [PRESET SETUP]. Select [ON/CLEAR] set it to [PROTECT ON] and close the menu.

To cancel the protection, reselect [PROTECT ON].

## Resetting a Custom Preset File

1. Open the menu and select [CUSTOM PRESET], followed by [PRESET SETUP].
2. Select [ON/CLEAR] and set it to [CLEAR].  
A confirmation message appears.
3. Select [Yes] and close the menu.



A protected preset file cannot be reset.

## Activating the Custom Preset Settings



### 1. Press the CUSTOM PRESET SELECT button.

- The setting changes with each press of the button in the order of "CP1", "CP2", "CP3" and "CPOFF".
- When you are not using the custom preset setting, set the camcorder to "CPOFF".

### 2. Press the CUSTOM PRESET ON/OFF button.

The setting is activated.

## Importing a Custom Preset Setting from Another XL2

You can import a custom preset setting from another XL2 and save it to your camcorder.

Use the optional CV-150F (4 pin-4 pin) DV Cable.

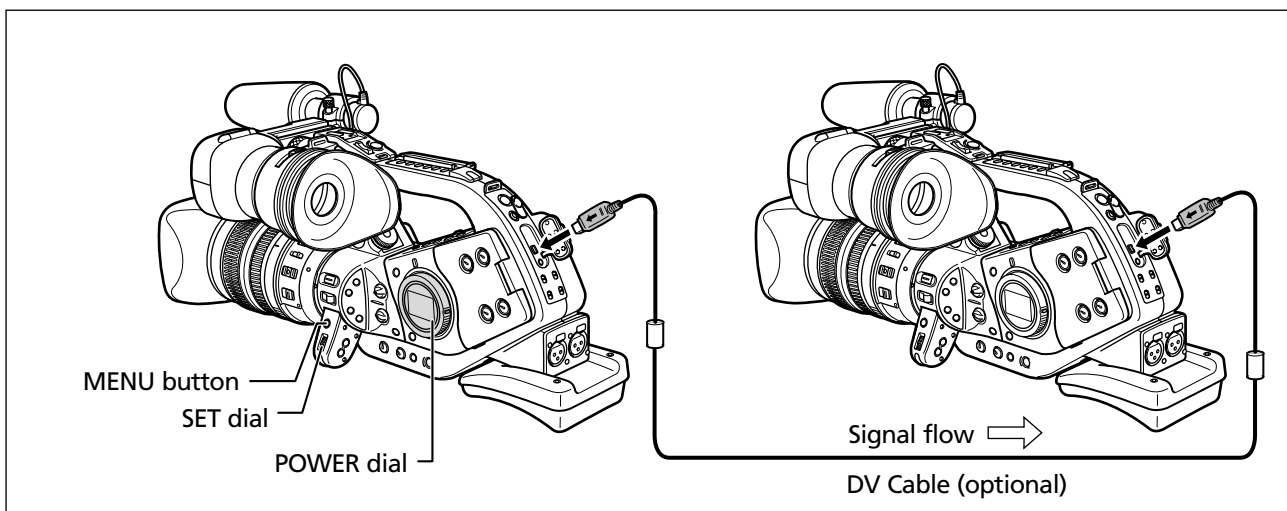

### Preparations

1. Connect the camcorders with a DV cable.
2. XL2 from which you wish import: Set the POWER dial to EXT. CONT.  
 XL2 to which you wish to import: Set the POWER dial to a recording program other than .

## Importing (Operation on the XL2 to which you import)

---

**1. Open the menu and select [CUSTOM PRESET] and [READ PRESET].**

The IMPORT PRES. menu appears.

**2. Select [SEL PRESET] and set it to the custom preset file you wish to import.**

**3. Select [SEL POSITION].**

The SEL POSITION menu appears.

**4. Select [SEL PRESET] and set it to the custom preset file you wish to overwrite.**

**5. Select [OVERWRITE].**

A confirmation message appears.

**6. Select [YES].**

The custom preset file is imported.



Make sure that protection is cancelled when saving a preset setting.



You can review but not change the preset settings of the connected XL2.

[READ PRESET] can only be selected when another XL2 is connected.

# Using Clear Scan for Recording Computer Screens

This feature allows you to record computer CRT screen or other equipment without displaying black band or flicker on the screen. You can adjust the frequency from 50.0 Hz to 200.7 Hz.

E

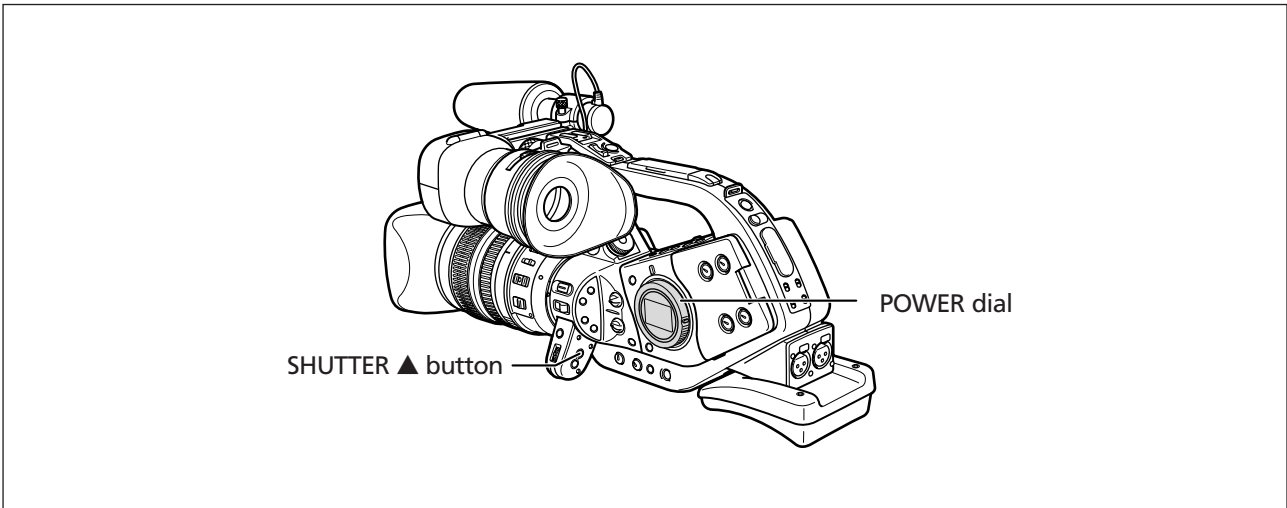

1. Set the POWER dial to **Tv** or **M**.
2. Press the SHUTTER ▲ button to display "CS".
3. Open the menu and select [CAMERA SETUP]. Select [CLEAR SCAN], adjust the frequency and close the menu.  
Select a frequency with which the black band does not appear.

Recording

# Using the Custom Keys

You can assign frequently used functions to the custom keys (for recording and VCR mode independently).

## Default settings:

	Recording Mode	VCR Mode
CUSTOM KEY 1	TIME CODE	TV SCREEN
CUSTOM KEY 2	INDEX WRITE	DATA CODE

Following functions can be assigned to the custom keys:

### CAMERA Mode

Time code  
Index write  
Zebra pattern  
VCR STOP\*  
TV screen  
Handle zoom speed  
Audio level indicator

### VCR Mode

Time code  
TV screen  
Data code  
Audio level indicator

\* Function that can only be operated by the custom keys.



To check the current custom key settings:

In recording mode: Open the menu and select [DISPLAY SETUP/☎]. Select [GUIDE INFO], set it to [CUSTOM KEYS] and close the menu.

In VCR mode: Open the menu and select [DISPLAY SETUP/☎]. Select [CUSTOM KEYS], set it to [ON] and close the menu.

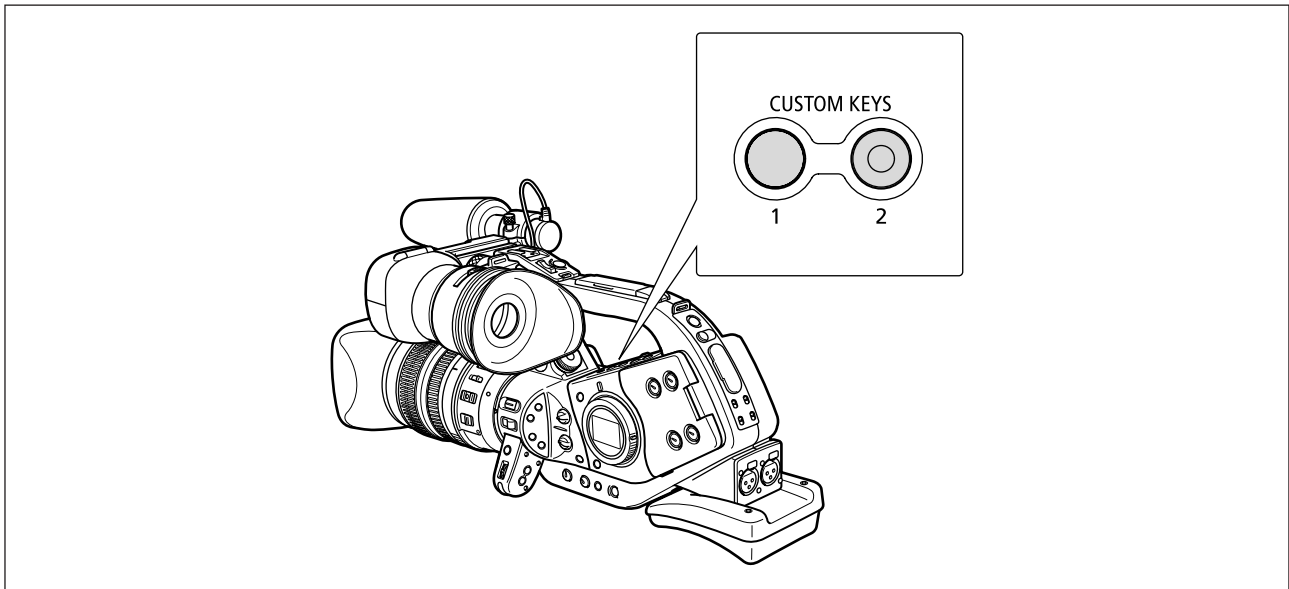

## Changing the custom keys setting

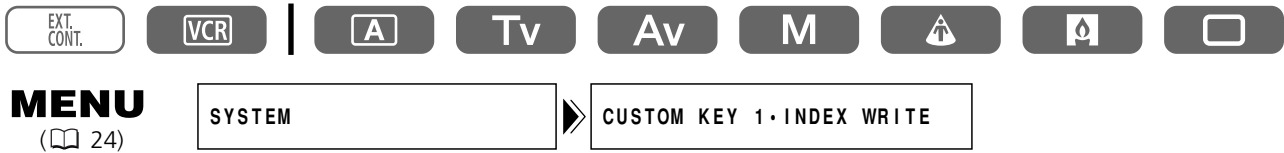

Open the menu and select [SYSTEM]. Select [CUSTOM KEY 1] or [CUSTOM KEY 2], select the function you wish to assign to the custom key and close the menu.

When you do not wish to use the custom keys, select [(NONE)].

## Activating the Functions with the Custom Key

### Time Code (📖 44)



Press the **CUSTOM KEY (1 or 2)** button.

The time code setting menu appears.

### Index Write

You can add an index signal to your recording for easy search in VCR mode.



Press the **CUSTOM KEY (1 or 2)** button.

- The index signal will be recorded for approx. 6 seconds.
- When the camcorder is in record pause mode, the index signal will be written when you start recording.



- An index signal cannot be added or erased later.
- Index write cannot be used during interval timer recording.

### Zebra Pattern (📖 62)



Press the **CUSTOM KEY (1 or 2)** button.

The zebra pattern is activated. Press the button again to deactivate it.

## VCR STOP ( 31)

---

In VCR STOP mode, the camcorder retains camera settings such as aperture and shutter speed, so you can adjust the camera section without worrying about the automatic shut-off.

VCR STOP can only be operated with the custom keys.



**Press the CUSTOM KEY (1 or 2) button.**

The VCR STOP mode is activated. Press the button again to return to record pause mode.

## TV Screen ( 102)

---

You can show the camcorder display on a connected TV.



**Press the CUSTOM KEY (1 or 2) button.**

## Handle Zoom Speed ( 36)

---



**Press the CUSTOM KEY (1 or 2) button.**

The ZOOM HANDLE menu appears. Select a setting option with the SET dial.

## Audio Level Indicator ( 49)

---



**Press the CUSTOM KEY (1 or 2) button.**

The audio level indicator appears. Press the button again to hide the audio level indicator.

## Data Code ( 90)

---



**Press the CUSTOM KEY (1 or 2) button.**

The data code appears. Press the button again to hide the data code.



# Recording Colour Bars/Audio Reference Signal

## Colour Bars

You can generate and record EBU (European Broadcast Union) colour bars.

E

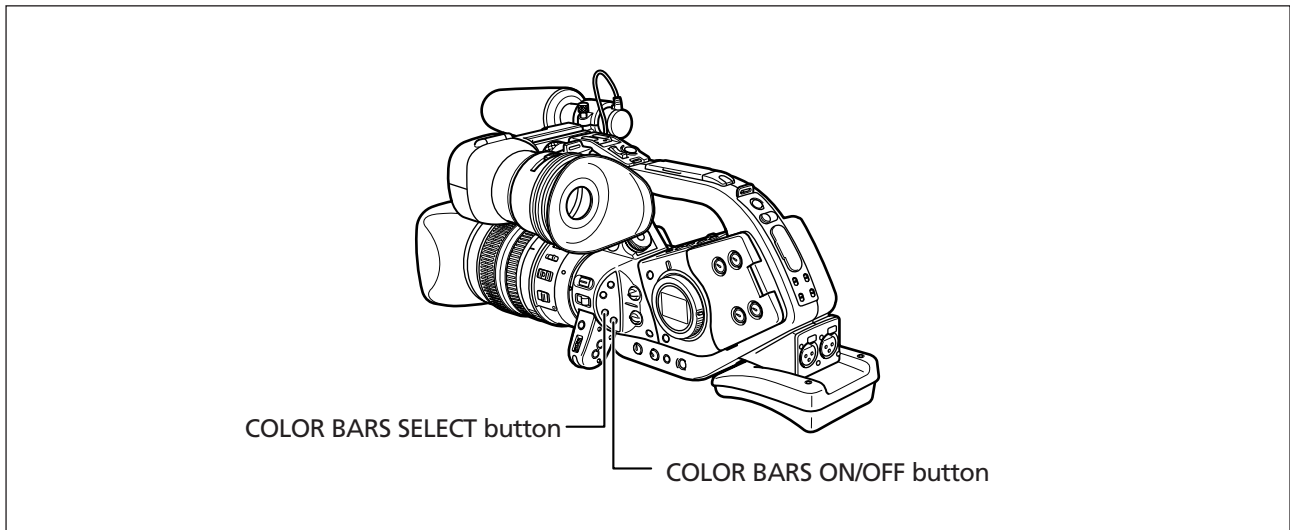

**1. Press the COLOR BARS SELECT button to display "COLOR BARS".**

The setting changes with each press of the button. "COLOR BARS" flashes.

**2. Press the COLOR BARS ON/OFF button.**

"COLOR BARS" stops flashing, and the colour bars appear. Press the button again to deactivate the colour bars.

Recording

## Audio Reference Signal

---

You can record a 1kHz audio reference signal (-12 dB or -20 dB) along with the colour bars.



### MENU

( 24)

AUDIO SETUP



1kHz TONE.....OFF

Open the menu and select [AUDIO SETUP]. Select [1kHz TONE], select the audio signal and close the menu.

The selected audio reference signal sounds.

# Recording with the Interval Timer

With the interval timer, you can record images over a selected time with a selected interval. This function is useful when shooting flowers, animals, and other natural events.

You can choose an interval from 30 seconds, 1 minute, 5 minutes and 10 minutes, and a recording time from 0.5 seconds, 1 second, 1.5 seconds, and 2 seconds.

Example: 2 seconds recording time at a 5 minutes interval

(= standby time of 5 minutes including the recording time of 2 seconds)

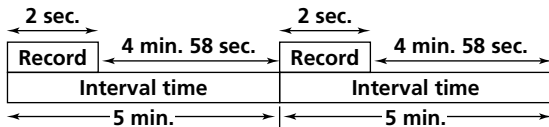

## Selecting Interval and Recording Time

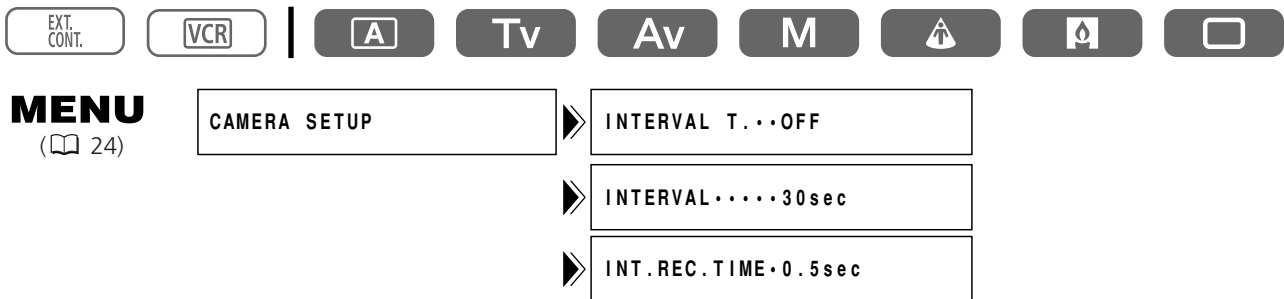

1. Open the menu and select [CAMERA SETUP].
2. Select [INTERVAL T.] and set it to [ON].
3. Select [INTERVAL] and select an interval.
4. Select [INT.REC.TIME] and select a recording time.
5. Close the menu.

"INT T." flashes.

## Recording with the Interval Timer

---



### Press the start/stop button to start recording.

- Interval recording starts and "INT T." stops flashing.
- When the interval is set to 30 seconds or 1 minute, the camcorder goes into record pause mode during the recordings. When set to 5 or 10 minutes, the camcorder goes into stop mode during the recordings.

### To Pause Interval Recording

---

#### Press the start/stop button.

- The camcorder returns to record pause mode and "INT T." starts flashing.
- Press the start/stop button to restart recording.

### To Finish Interval Recording

---

#### 1. Press the start/stop button.

#### 2. Open the menu and select [CAMERA SETUP]. Select [INTERVAL T.], set it to [OFF] and close the menu.



- When you record for a long time (more than 12 hours), we recommend turning off the screen display by pressing the EVF DISPLAY button.
- When the display remains shown on the screen, turn off the camcorder. They will disappear in a few hours.
- The remaining tape display may not appear.

# Recording with the Self-Timer

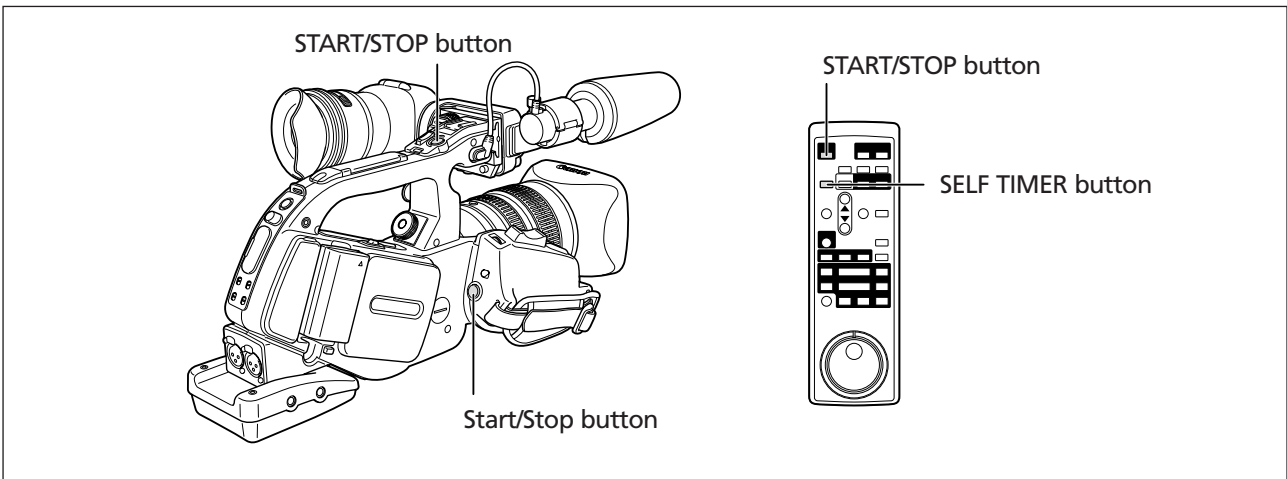

## 1. Press the SELF TIMER button on the wireless controller.

"⌚" appears.

## 2. Press the start/stop button.

The camcorder starts recording after a 10-second countdown (2 seconds when using the wireless controller). The countdown appears on the screen.



- To cancel the self-timer, press the SELF TIMER button. Once the countdown has begun, you can also press the start/stop button to cancel the self-timer.
- The self-timer will be cancelled when you turn off the camcorder.
- The self-timer can also be activated through the menu: Open the menu and select [CAMERA SETUP]. Select [SELF TIMER], set it to [ON ⌚] and close the menu.

# Using the DV Control

This feature enables the XL2 to control the record and stop function of a connected IEEE1394 storage/recording device. The device must comply with the IEEE1394 AV/C protocol.

Users of Windows XP can also download the DV-PC Recorder from the Canon Homepage to record video/audio to the computer's hard disk. For details, refer to the *DV-PC Recorder Software* leaflet.

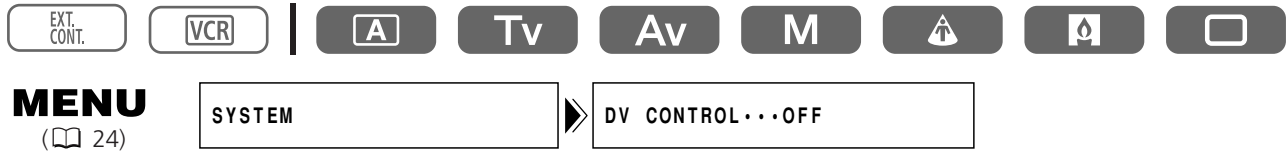

1. Open the menu and select [SYSTEM]. Select [DV CONTROL], set it to [ON] and close the menu.

2. Press the start/stop button.

**When the XL2 is in record pause mode:**

XL2: Recording

Connected device: Recording

**When the XL2 is recording:**

XL2: Record pause mode

Connected device: Record pause mode

**When the XL2 is not ready for recording (no cassette loaded etc.)**

Connected device: Recording/record pause mode

**After loading a cassette while the connected device is recording:**

XL2: Recording

Connected device: Continues recording

Pressing the start/stop button again:

XL2: Record pause mode

Connected device: Record pause mode



○ The status of the connected device is indicated as follows:



Connected device is recording



Connected device is in record pause or stop mode



Connected device is in a mode other than record pause or stop



[DV CONTROL] is set to [ON], but no DV device is connected

○ When the XL2 stops recording without operating the start/stop button (e.g. tape has reached the end) while both the XL2 and the connected device are recording, the connected device continues recording.

○ When connecting two XL2s via a DV cable, make sure to set [DV CONTROL] of the connected device to [OFF].

○ Only one device can be connected to the XL2 for DV control.

○ DV control may not work properly depending on the connected non-Canon device.

○ The DV control setting is retained by the camcorder even if you turn the power off. Make sure to check the setting after use of the DV control function, as the tape in the connected device may be overwritten.

○ Do not use a DV cable longer than 4.5 m.

# Other Camcorder Functions/Settings

## Changing the Recording Mode (SP/LP)

You can choose between SP (standard play) and LP (long play). LP extends the tape usage by 1.5 times.

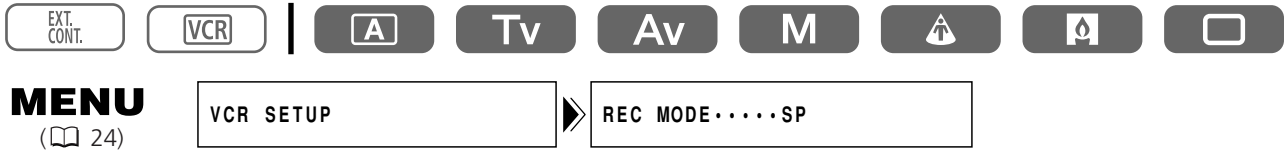

To change to LP mode, open the menu and select [VCR SETUP]. Select [REC MODE], set it to [LP] and close the menu.



Depending on the nature and usage condition of the tape, picture and sound recorded in LP mode may be distorted. We recommend using the SP mode for important recordings.



- If you record in both SP and LP modes on the same tape, the playback picture may become distorted, and the time code may not be written correctly.
- If you play back a tape that has been recorded in LP mode with another digital device on this camcorder, or vice versa, picture and sound may become distorted.

## Superimposing the Screen Displays

Character record is a feature that allows for the superimposition of meta data - month, day, hour, minute and second - permanently burned on to the video. This is ideal for surveillance and law enforcement use.

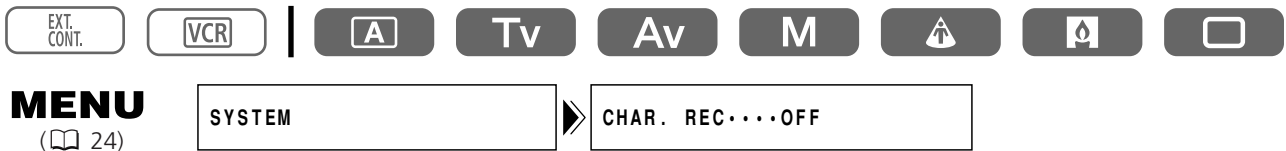

Open the menu and select [SYSTEM]. Select [CHAR. REC], set it to [ON] and close the menu.



- Make sure to set [CHAR. REC] to [OFF] when you do not wish to superimpose the screen displays.
- Superimposed screen displays cannot be erased later.

## Turning Off the Tally Lamps

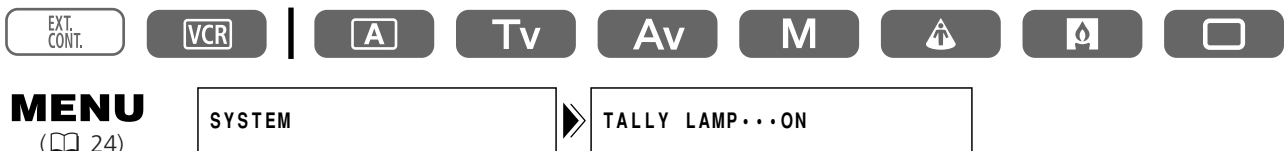

Open the menu and select [SYSTEM]. Select [TALLY LAMP], set it to [OFF] and close the menu.

The tally lamps still light up when the camcorder receives a signal from the wireless controller, or during self-timer countdown.

## Changing the Display Language

The language used in the camcorder displays and menu items can be changed to Simplified Chinese or Japanese.

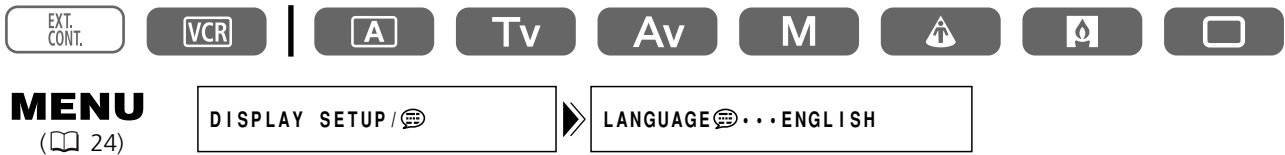

To change the display language, open the menu and select [DISPLAY SETUP/ 🗨️]. Select [LANGUAGE 🗨️], select a language and close the menu.



- If you have mistakenly changed the language, follow the 🗨️ mark next to the menu item to change the setting.
- The displays "MENU" and "SET" at the bottom of the screen refer to the button names on the camcorder and will not change when you change the language.

## Changing the Date Format

You can select between three date formats. For example, [1. JAN. 2004], [JAN. 1, 2004] and [2004. 1. 1].

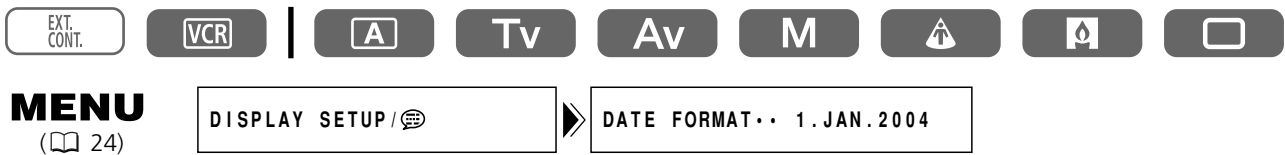

Open the menu and select [DISPLAY SETUP/ 🗨️]. Select [DATE FORMAT], select a format and close the menu.



# Playing Back a Tape

If the playback picture is distorted, clean the video heads using a Canon Head Cleaning Cassette or a commercially available digital video head-cleaning cassette (📖 108).

E

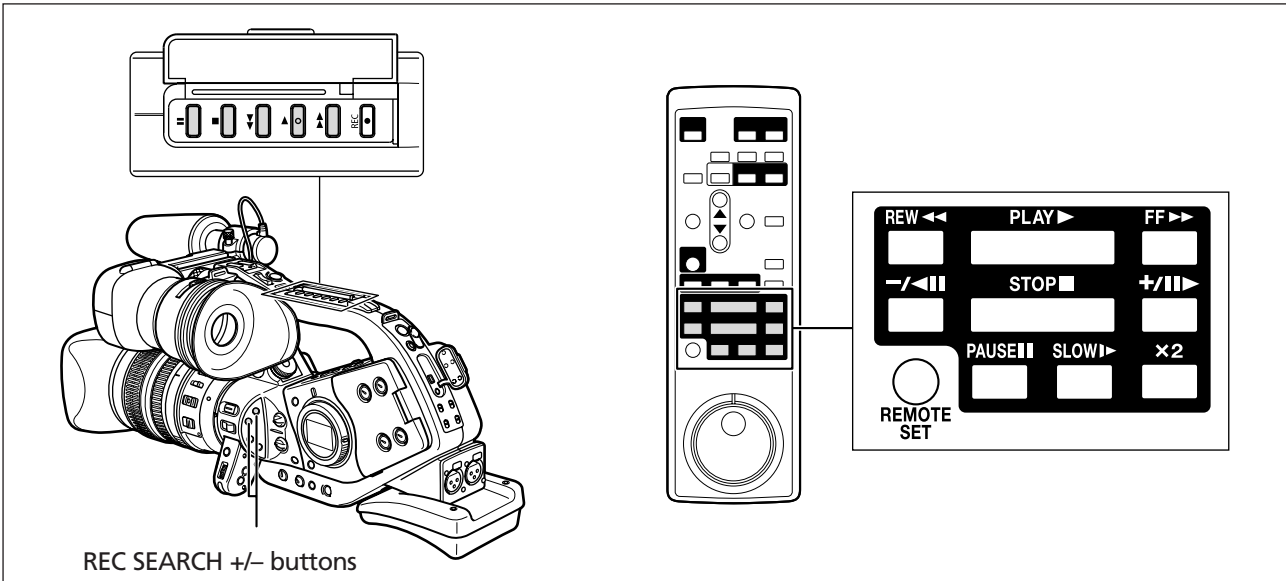

1. Set the POWER dial to VCR.
2. Press the ◀◀ button to rewind the tape.
3. Press the ▶▶ button to begin playback.
4. Press the ■ button to stop playback.

## Special Playback Modes

### ■ (Playback Pause)

To pause playback, press the ■ button during normal playback.

### ▶▶ (Fast Forward Playback) / ◀◀ (Rewind Playback)

Plays back the tape at 11.5 times normal speed (forward or reverse). Press and hold the button during normal playback or fast forward.

### -/◀◀ (Reverse Playback)

Press the button on the wireless controller during normal playback. Press the ▶▶ (play) button to return to normal playback.

### +/▶▶ (Frame Advance) / -/◀◀ (Frame Reverse)

Plays back frame-by-frame. Press the button on the wireless controller repeatedly during playback pause. Press and hold it to play back continuous frame advance/frame reverse.

Playback

## **SLOW ▶ (Slow Forward)/(Slow Reverse)**

Plays back at about 1/3 normal speed. Press the button on the wireless controller during normal or reverse playback. Press the ▶ (play) button to return to normal playback.

## **× 2 (Forward ×2 Playback)/(Reverse ×2 Playback)**

Plays back at 2 times normal speed. Press the button on the wireless controller during normal or reverse playback. Press the ▶ (play) button to return to normal playback.

## **Edit search**

Press and hold the REC SEARCH +/- button in playback pause mode. When you release the button, the camcorder returns to playback pause mode.



- There is no sound during special playback.
- The picture may become distorted during some special playback modes.
- The camcorder stops the tape automatically after 5 minutes in playback pause mode to protect tape and video heads.

## **Shuttle Dial**

Use the shuttle dial in play or playback pause mode to control the playback speed and direction. Turn the shuttle dial to select slow, ×1 and ×2 playback modes (both forward and reverse), as well as fast forward and rewind playback. Turn it fully to the left/right to rewind/fast forward while the tape is stopped.

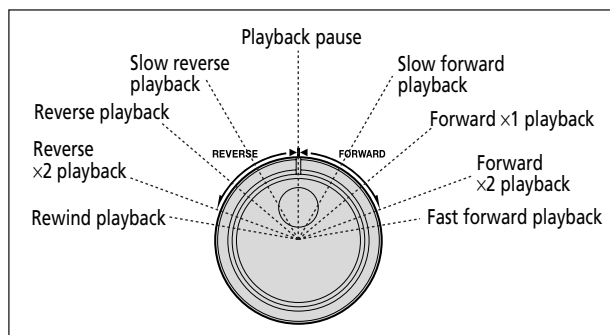

## **Jog Dial**

Turn the Jog dial during playback or playback pause for frame advance/reverse or slow forward/slow reverse playback (depending on how far you turn the dial).

When you stop turning the dial, the camcorder goes into playback pause mode.

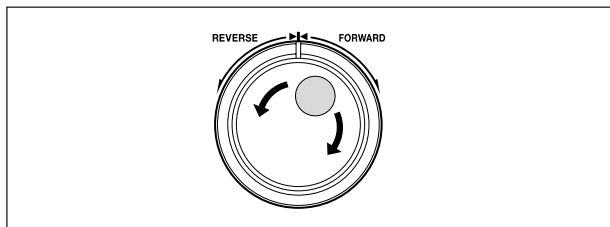

# Playing Back on a TV Screen

## TVs with S (S1)-Video Input Terminal

Refer also to the TV or VCR instruction manual.

E

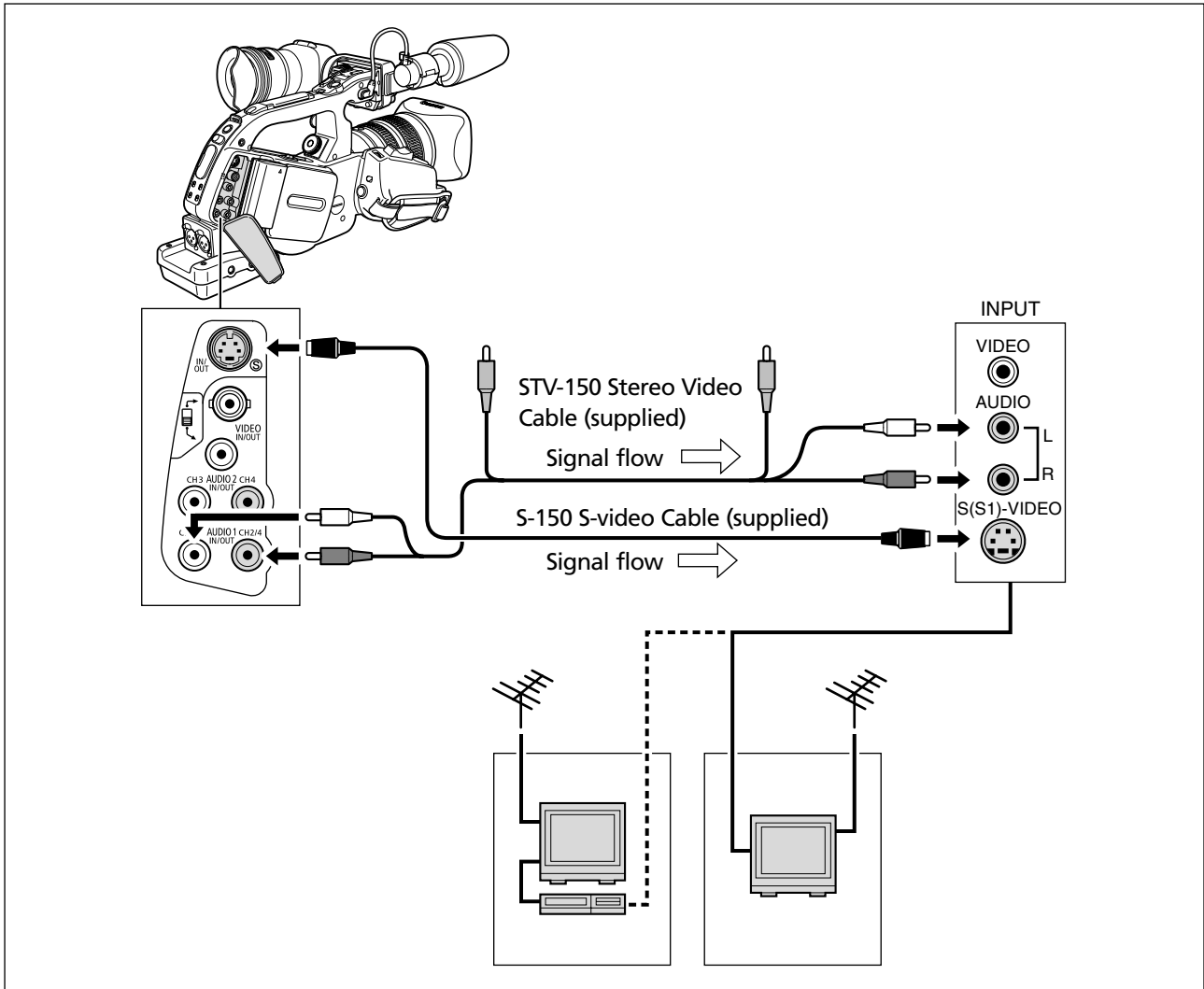

1. Turn off all devices before starting the connections.
2. Connect the S-150 S-video Cable to the S-video terminals.
3. Connect the STV-150 Stereo Video Cable to the camcorder's AUDIO1 terminals and the audio terminals of the TV/VCR.
4. If connecting to a TV, set the input selector to VIDEO. If connecting to a VCR, set the input selector to LINE.



- We recommend powering the camcorder from a household power source.
- The picture quality is higher when connecting to a TV with an S (S1) terminal.

Playback

## TVs with SCART Terminal

Refer also to the TV or VCR instruction manual.

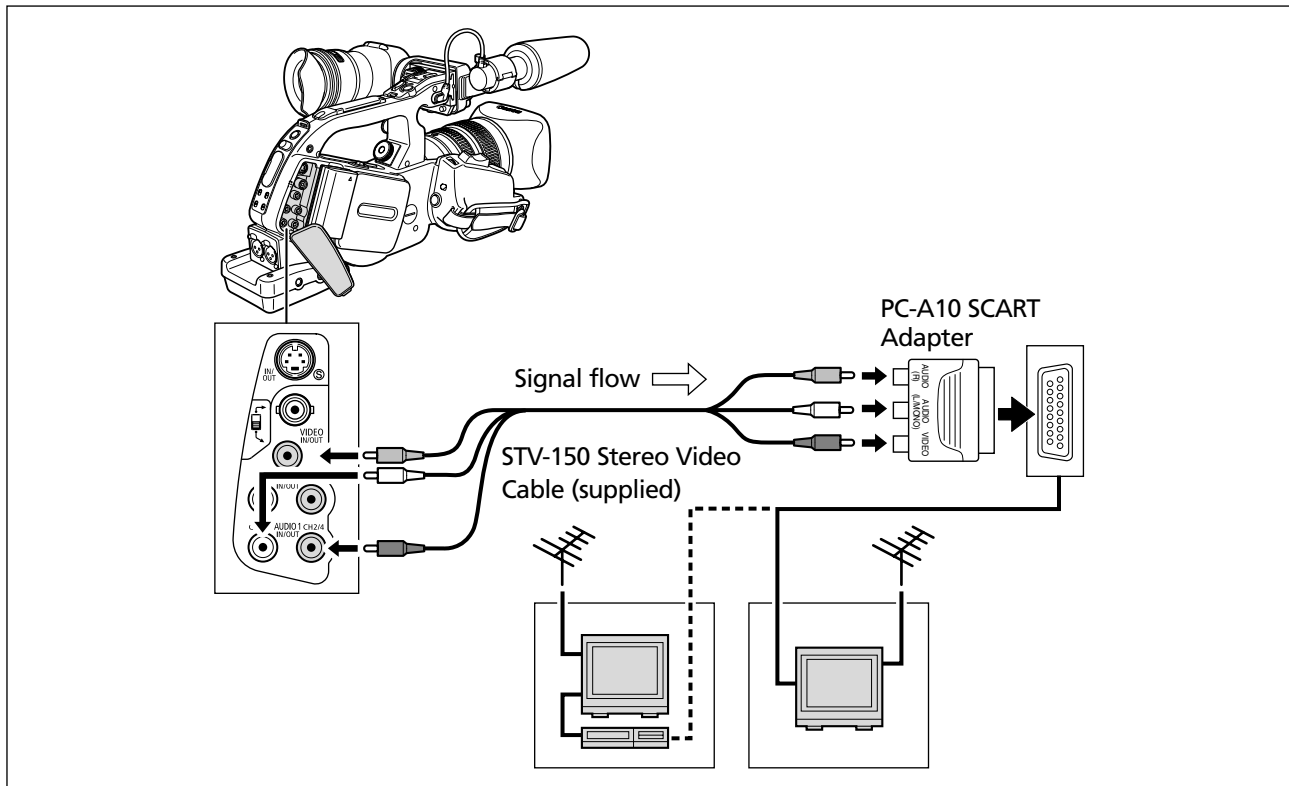

1. Turn off all devices before starting the connections.
2. Connect the PC-A10 SCART Adapter to the TV or VCR's SCART terminal.
3. Connect the STV-150 Stereo Video Cable to the camcorder's VIDEO and AUDIO1 terminals and the audio/video terminals on the SCART Adapter.
4. If connecting to a TV, set the input selector to VIDEO. If connecting to a VCR, set the input selector to LINE.



- The supplied PC-A10 SCART Adapter is for output only. For analog line-in recording or analog-digital conversion, please use a SCART Adapter with input capability (commercially available).
- When connecting to the RCA terminal, set the RCA/BNC selector to RCA. When connecting to the BNC terminal, set the RCA/BNC selector to BNC.

## TVs with Audio/Video Terminals

Refer also to the TV or VCR instruction manual.

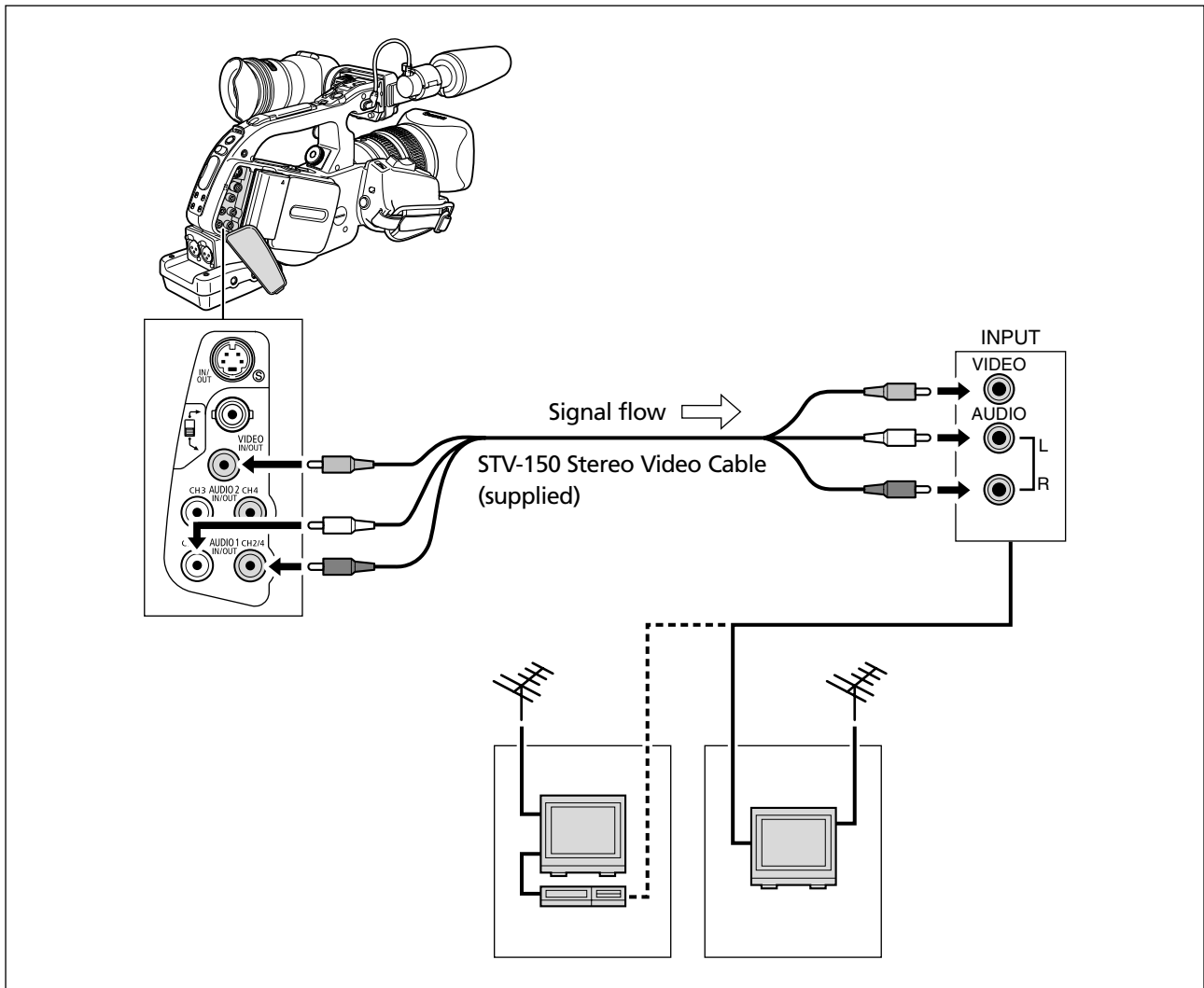

1. Turn off all devices before starting the connections.
2. Connect the STV-150 Stereo Video Cable to the camcorder's VIDEO and AUDIO1 terminals and the audio/video terminals on the TV/VCR.
3. If connecting to a TV, set the input selector to VIDEO. If connecting to a VCR, set the input selector to LINE.



When connecting to the RCA terminal, set the RCA/BNC selector to RCA. When connecting to the BNC terminal, set the RCA/BNC selector to BNC.

# Audio Output

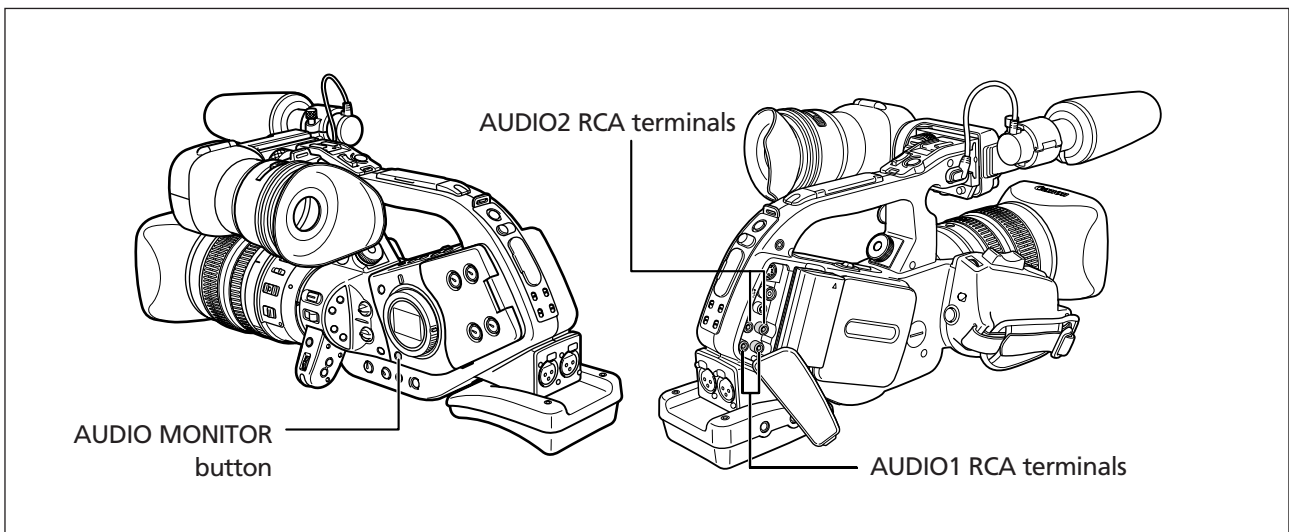

## Selecting the Audio Output of the RCA Terminals



Press the **AUDIO MONITOR** button.

The setting changes with each press of the button in the order of CH  $\frac{1}{2}$ , CH  $\frac{3}{4}$  and CH  $\frac{1}{2}$ +CH  $\frac{3}{4}$ .

## Selecting the Audio Channels



**MENU**

( 24)

AUDIO SETUP



SEL AUDIO CH·CH1/CH2

Open the menu and select [AUDIO SETUP]. Select [SEL AUDIO CH], select a setting option and close the menu.

## Selecting the Audio Mix



**MENU**

( 24)

AUDIO SETUP



MIX SELECT...VARIABLE

1. Open the menu and select [AUDIO SETUP]. Select [MIX SELECT], set it to [VARIABLE] or [FIXED] and close the menu.
2. When you have selected [VARIABLE], adjust the mix balance with the MIX BALANCE CH1/2 and CH3/4 buttons on the wireless controller.

# Returning to a Pre-marked Position

If you wish to return to a particular scene later, mark the point with the zero set memory, and the tape will stop at that point when you rewind/fast forward the tape. This function is operated with the wireless controller.

E

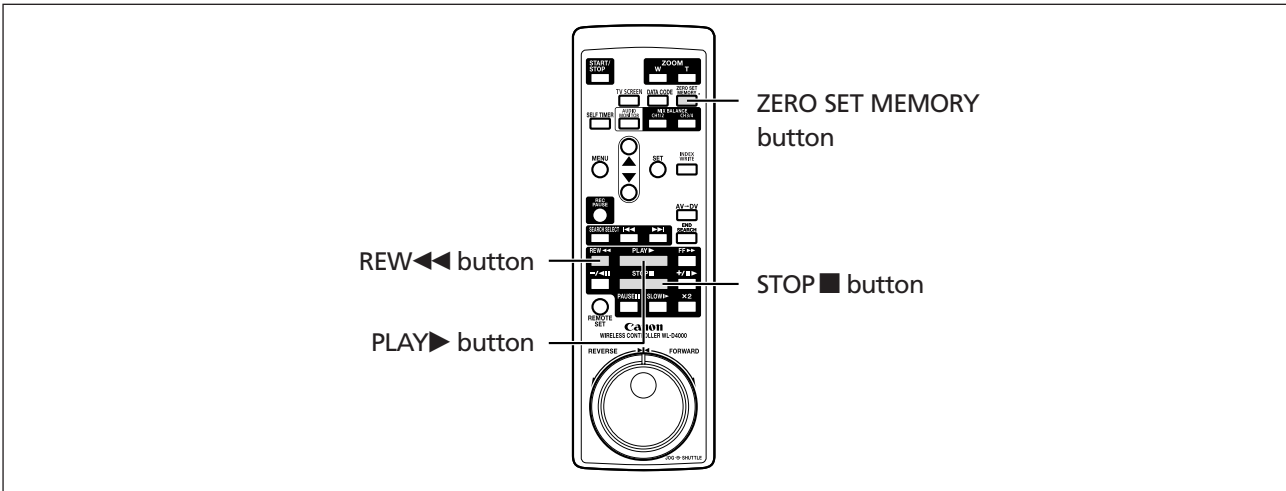

- 1. Press the ZERO SET MEMORY button at the point you wish to return to later.**
  - "0:00:00 M" appears.
  - To cancel, press the ZERO SET MEMORY button again.
- 2. When you have finished playback, rewind the tape.**
  - "◀◀ RTN" appears.
  - The tape stops automatically at "0:00:00".
  - The tape counter changes to time code.



The zero set memory may not function correctly when the time code has not been recorded consecutively.

Playback

# Index Search

You can locate the point at which you have recorded the index signal (📖 71).  
This function is operated with the wireless controller.

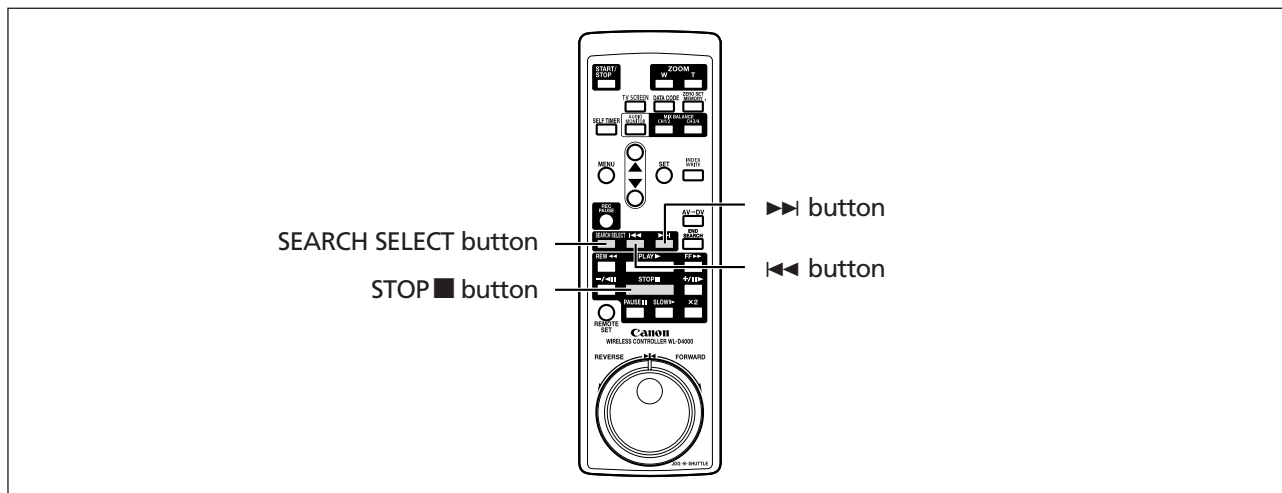

1. Press the **SEARCH SELECT** button to display "INDEX SEARCH".
2. Press the **▶▶** or **◀◀** button to begin searching.
  - Press more than once to search for further index signals (up to 10 times).
  - Press the **STOP** button to stop searching.



Playback may start slightly before or after the index signal.



# Date Search

You can locate the change of the date/time zone with the date search function. This function is operated with the wireless controller.

E

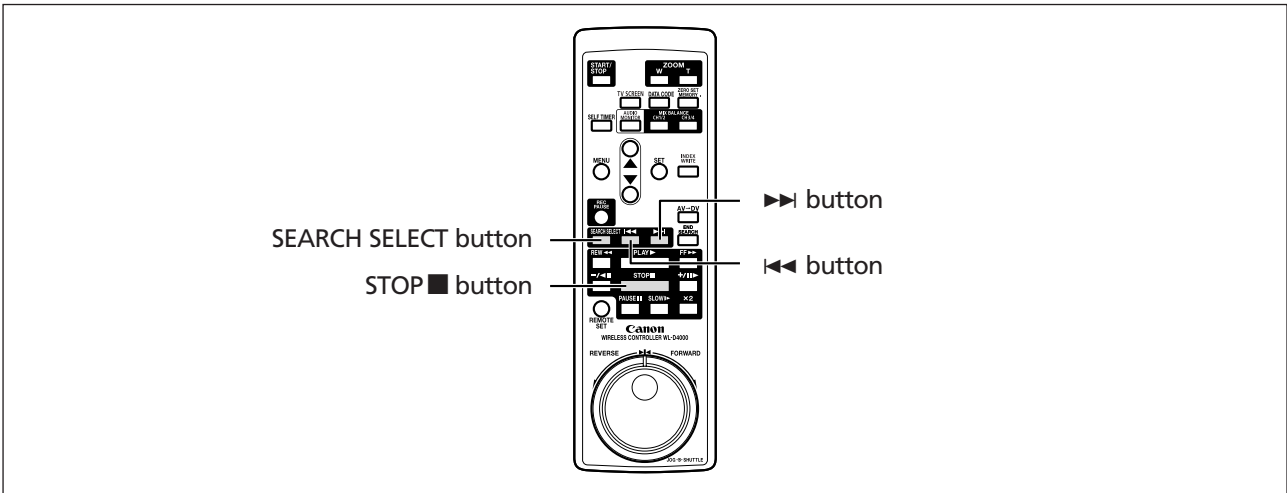

1. Press the **SEARCH SELECT** button to display "DATE SEARCH".

2. Press the **▶▶** or **◀◀** button to begin searching.

- Press more than once to search for further date changes (up to 10 times).
- Press the **STOP** button to stop searching.



- A recording of longer than a minute per date/area is required.
- Date search may not function if the data code is not correctly displayed.

# Displaying the Data Code

The camcorder maintains a data code containing recording date and time and other camera data such as shutter speed, gain and exposure (f-stop). When you play back a tape, you can display the data code and select the data code combination you wish to display.

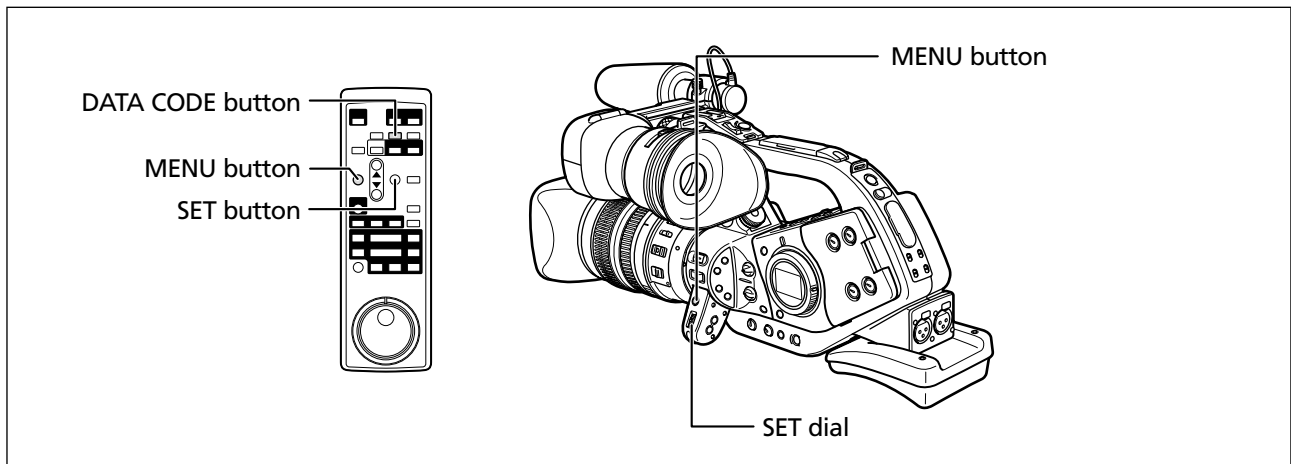

## Selecting the Date/Time Display Combination



**MENU**  
( 24)



Open the menu and select [DISPLAY SETUP/ ]. Select [D/TIME SEL.], set it to [DATE] or [TIME] and close the menu.

## Selecting the Data Code Display Combination



**MENU**  
( 24)



Open the menu and select [DISPLAY SETUP/ ]. Select [DATA CODE], set it to [CAMERA DATA] or [CAM.& D/T] and close the menu.

## Displaying the Data Code



Press the **DATA CODE** button on the wireless controller.



The data code will not display the next time you turn on the camcorder.

## Six-Second Auto Date

Date and time appear for 6 seconds when you begin playback, or to indicate that date or time zone has changed.



**MENU**  
( 24)

DISPLAY SETUP /



6SEC.DATE...OFF

Open the menu and select **[DISPLAY SETUP/ ]**. Select **[6SEC.DATE]**, set it to **[ON]** and close the menu.

# Changing the Remote Sensor Mode

---

Two remote sensor modes and an off setting are available to prevent interference from other Canon wireless controllers being used nearby.

## Turning the Remote Sensor Off

---

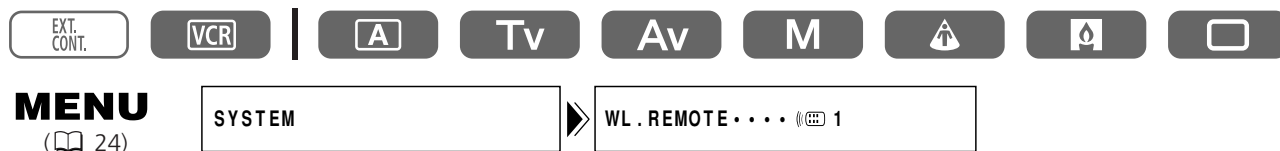

Open the menu and select [SYSTEM]. Select [WL.REMOTE], set it to [OFF ] and close the menu.

"" appears.

## Changing the Remote Sensor Mode

---

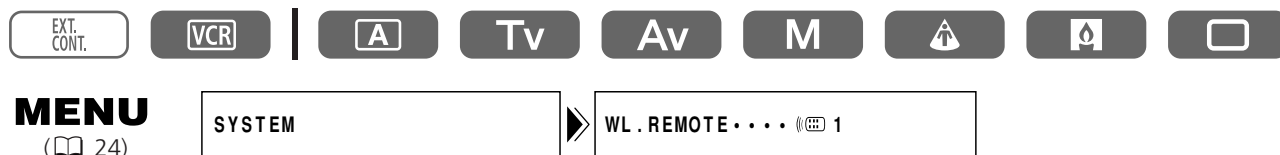

**1. On the camcorder, open the menu and select [SYSTEM]. Select [WL.REMOTE], set it to  2] and close the menu.**

The selected mode appears for a few seconds.

**2. On the wireless controller, press and hold the REMOTE SET button. Press the ZOOM T button for mode 2. Keep the button pressed for over 2 seconds.**

If you have set the camcorder to mode 1, press the ZOOM **W** button for mode 1.



- The wireless controller returns to mode 1 when you replace the batteries. Change the mode if necessary.
- Make sure that camcorder and wireless controller are set to the same mode. Display the camcorder's mode by pressing any button on the wireless controller (except of the REMOTE SET button) and set the wireless controller's mode to the same mode. Change the batteries if the wireless controller still does not work.

# Recording to a VCR or Digital Video Device

You can copy your recordings by connecting the camcorder to a VCR or a digital video device. If you connect a digital video device, you can copy recordings with virtually no generation loss in image and sound quality.

## Connecting the Devices

### ① Connecting a VCR

See *Playing Back on a TV Screen* (□ 83).

### ② Connecting a Digital Video Device

Use the optional CV-150F (4 pin–4 pin) or CV-250F (4 pin–6 pin) DV Cable.

Refer also to the instruction manual of the digital video device.

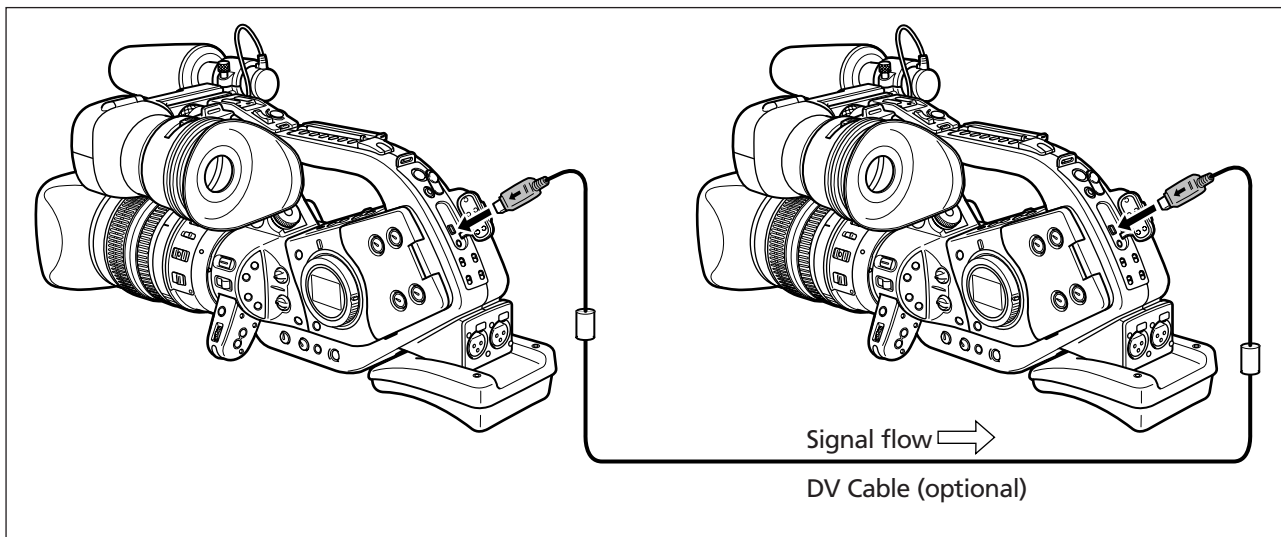

## Recording



1. Set the **POWER** dial to **VCR** and load a recorded cassette.
2. **Connected device:** Load a blank cassette and set the device to record pause mode.
3. Locate the scene you wish to copy and pause playback shortly before the scene.
4. Play back the tape.
5. **Connected device:** Begin recording when the scene you wish to copy appears. Stop recording when copying is complete.
6. Stop playback.



- When connecting a VCR, the quality of the edited tape will be slightly lower than that of the original.
- When connecting a digital video device:
  - If the picture does not appear, reconnect the DV cable or turn the camcorder off and back on again.
  - Proper operation cannot be guaranteed for all digital video devices equipped with a DV terminal. If operation does not work, use the S-video or the audio and video terminals.

# Recording from Analog Video Devices (VCR, TV or Camcorder)

---

You can record videos or TV programs from a VCR or analog camcorder on the tape in the camcorder.



**1. Connect the camcorder to the analog video device.**

See *Playing Back on a TV Screen* (□ 83).

**2. Set the POWER dial to VCR and load a blank cassette.**

**3. Open the menu and select [AUDIO SETUP]. Select [AUDIO MODE], select a setting option and close the menu.**

**4. Select the audio input.**

2-channel recording: Select the input with the INPUT SELECT switch of AUDIO1 (for analog line-in, set it to AUDIO1).

4-channel recording: Select the input with the INPUT SELECT switch of AUDIO1 and AUDIO2 (for analog line-in, set it to AUDIO1 and AUDIO2).

**5. Connected device: Load the recorded cassette.**

**6. Press the ● and ■ button (or the REC PAUSE button on the wireless controller).**

In record pause mode and during recording, you can check the picture on the screen.

**7. Connected device: Play back the tape.**

**8. Press the ■ button (or the PAUSE ■ button on the wireless controller) when the scene you wish to record appears.**

Recording starts.

**9. Press the ■ button to stop recording.**

- Press the ■ button to pause recording.
- Press the ■ button again to restart recording.

**10. Connected device: Stop playback.**



○ When you press only the ● button in step 6, recording starts immediately.

○ When connecting to a TV/video with SCART terminal, use a SCART adapter with input capability (commercially available). The supplied SCART Adapter PC-A10 is for output only.

## Recording from Digital Video Devices (DV Dubbing)

You can record from other digital video devices equipped with a DV terminal with virtually no loss in picture and sound quality.



**1. Connect the camcorder to the digital video device.**

See *Connecting a Digital Video Device* (□ 93).

**2. Set the POWER dial to VCR and load a blank cassette.**

Make sure that [AV→DV] is set to [OFF] (□ 98).

**3. Connected device: Load the recorded cassette.**

**4. Press the ● and || button (or the REC PAUSE button on the wireless controller).**

In record pause mode and during recording, you can check the picture on the screen.

**5. Connected Device: Play back the tape.**

**6. Press the || button (or the PAUSE || button on the wireless controller) when the scene you wish to record appears.**

Recording starts.

**7. Press the ■ button to stop recording.**

- Press the || button to pause recording.
- Press the || button again to restart recording.

**8. Connected Device: Stop playback.**



- Blank sections may be recorded as anomalous picture.
- If the picture does not appear, reconnect the DV cable or turn the camcorder off and back on again.
- You can only record signals from devices with the DV logo recording in SD system in SP or LP format.
- When you press only the ● button in step 4, recording starts immediately.

## **Concerning Copyright**

---

### **Copyright Precaution**

Certain pre-recorded video tapes, films and other materials, as well as some television programmes are copyrighted. Unauthorised recording of these materials may violate copyright protection laws.

### **Copyright Signals**

During playback: If you try to play back a tape that contains copyright control signals for protection of software, "COPYRIGHT PROTECTED PLAYBACK IS RESTRICTED" appears for a few seconds and the camcorder displays a blank blue screen. You cannot playback the contents of the tape.

During recording: If you try to record from software that contains copyright control signals for protection of software, "COPYRIGHT PROTECTED DUBBING RESTRICTED" appears. You cannot record the contents of the software.

You cannot record copyright protection signals to a tape using this camcorder.



# Converting Analog Signals into Digital Signals (Analog-Digital Converter)

By connecting the camcorder to a VCR or 8mm video camcorder, you can convert analog video/audio signals to digital signals and output the digital signals via the DV terminal. The DV terminal serves as output terminal only.

## Connecting the Devices

Turn off all devices before starting the connections. Unload the tape from the camcorder. Refer also to the instruction manual of the connected device. Use the optional CV-150F (4 pin-4 pin) or CV-250F (4 pin-6 pin) DV Cable.

You can also connect to the VIDEO terminal (📖 85).

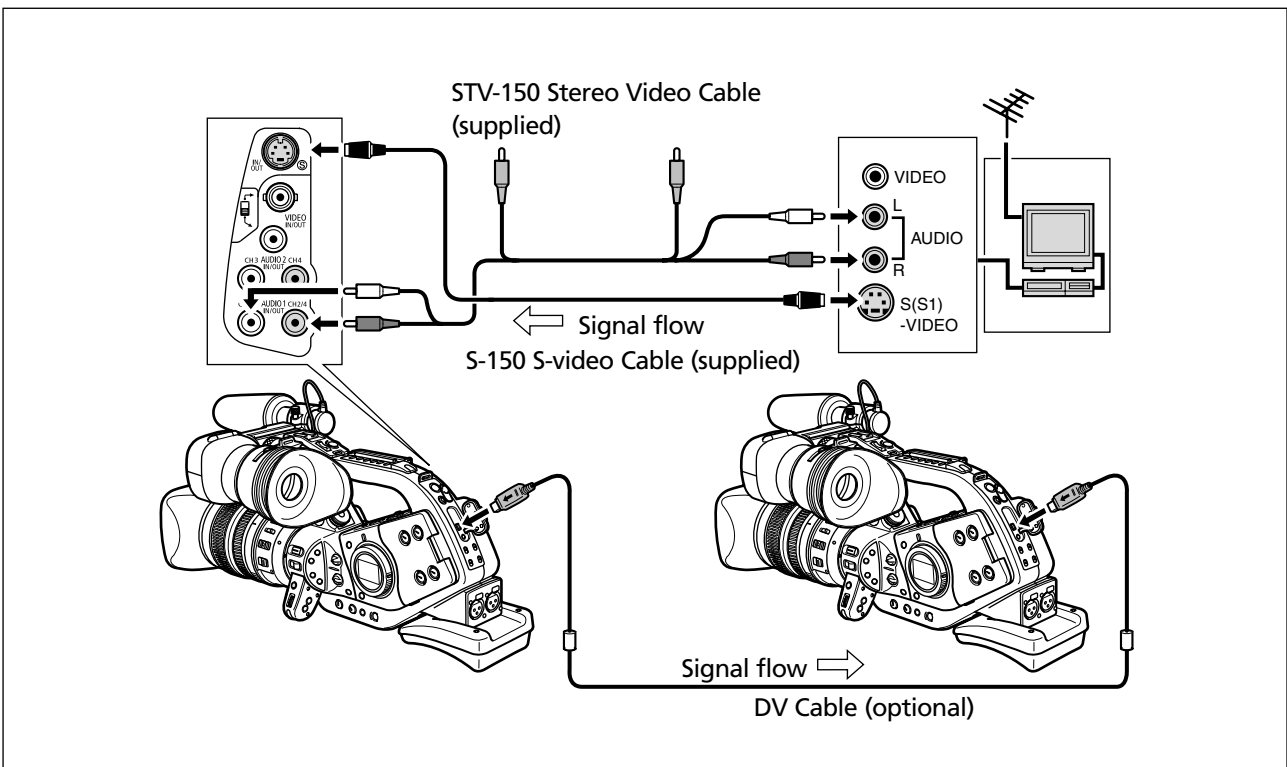

## Turning On the Analog-Digital Converter

---

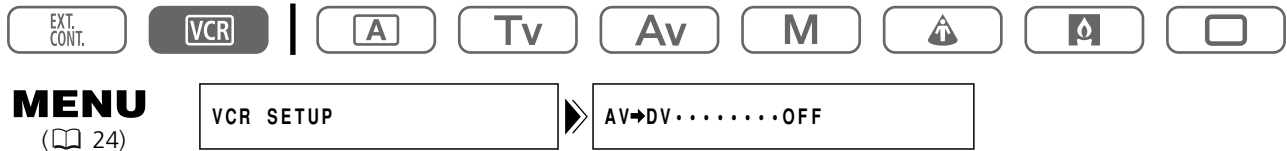

Open the menu and select [VCR SETUP]. Select [AV→DV], set it to [ON] and close the menu.

---



- Depending on the signal sent from the connected device, the conversion from analog to digital signals might not work properly (e.g., signals that include copyright protective signals or anomalous signals such as ghost signals).
- When connecting to a TV/video with SCART terminal, use a SCART adapter with input capability (commercially available). The supplied SCART Adapter PC-A10 is for output only.
- For normal use, set [AV→DV] to [OFF]. If it is set to [ON], digital signals cannot be input via the camcorder's DV terminal.
- Depending on the software and the specifications of your computer, you may not be able to transfer converted signals via the DV terminal.



- We recommend powering the camcorder from a household power source.
- You can also press the AV→DV button on the wireless controller. The setting changes with each press of the button.

# Connecting to a Computer Using a DV (IEEE1394) Cable

You can transfer recordings to a computer equipped with a IEEE1394 (DV) terminal or IEEE1394 capture board. Use the editing software supplied with your computer/capture board to transfer video recording from tape to computer. Refer to the instruction manual of the software.

A driver is preinstalled on Windows operating systems later than Windows 98 Second Edition and on Mac operating systems later than Mac OS 9, and will be installed automatically.

Users of Windows XP can also download the DV-PC Recorder from the Canon Homepage to record video/audio to the computer's hard disk. For details, refer to the *DV-PC Recorder Software* leaflet.

Use the optional CV-150F (4 pin-4 pin) or CV-250F (4 pin-6 pin) DV Cable.

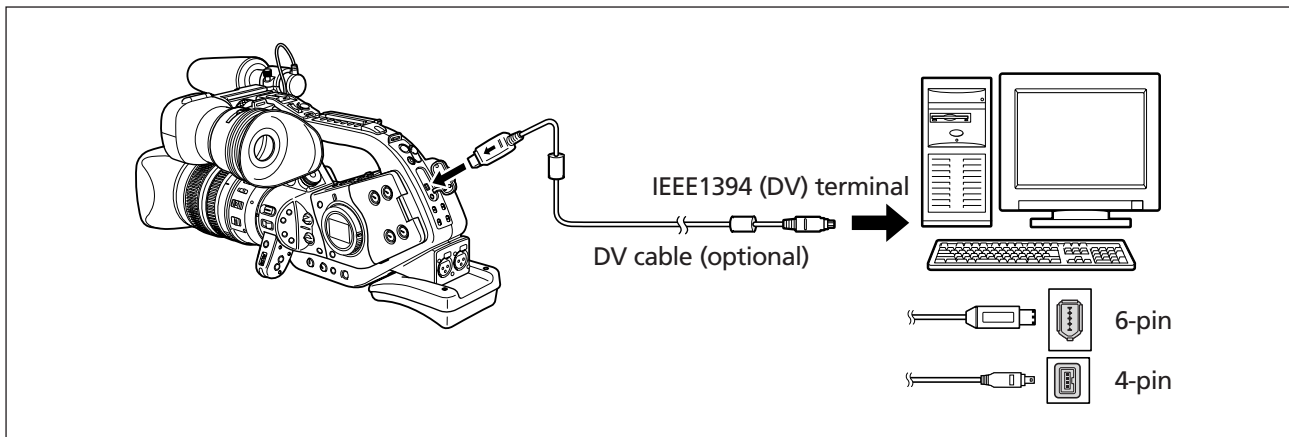

- Operation may not work correctly depending on the software and the specifications/settings of your computer.
- If the computer freezes while you have connected the camcorder, disconnect and reconnect the DV cable. If the problem persists, disconnect the interface cable, turn off camcorder and computer, turn camcorder and computer back on and reconnect them.
- The XL2 cannot be used with DV Messenger.



Refer also to the instruction manual of the computer.

# Settings Retained at Power Off or STANDBY Mode

The following list shows the settings that are retained when you turn the power off or press the STANDBY button when the backup battery is installed.

## Recording Mode

	Power Off	STANDBY Mode
Aperture setting in Av mode		○
Shutter speed setting in Tv mode		○
Aperture, shutter speed setting in Manual mode		○
Custom white balance		○
Exposure lock on/off	Returns to off	○
Aperture, shutter speed setting during exposure lock	Reset	○
Colour bars setting	Reset	○
Colour bars on/off	Reset	○
CAMERA MENU settings*		○
Self-timer on/off	Returns to off	
Interval timer on/off	Returns to off	
TV SCREEN on/off		○
EVF display	Returns to normal display	
Side panel light	Returns to off	
Zero set memory		○

\* Except for self-timer and interval timer on/off.

The following list shows the settings that are retained when you change the programmed AE mode or frame rate.

### Recording Mode

	When you change to another programmed AE mode other than Easy Recording	When you change to Easy Recording mode	When you change the frame rate
Aperture setting in Av mode	<input type="radio"/>		Reset
Shutter speed setting in Tv mode	<input type="radio"/>		Reset
Aperture, shutter speed setting in Manual mode	<input type="radio"/>		Reset
Custom white balance	<input type="radio"/>		<input type="radio"/>
Exposure lock on/off	Returns to off		
Aperture, shutter speed setting during exposure lock	Reset		
Colour bars setting	<input type="radio"/>		Reset
Colour bars on/off	<input type="radio"/>		Reset
CAMERA MENU setting		<input type="radio"/>	
Self-timer on/off		<input type="radio"/>	
Interval timer on/off		<input type="radio"/>	
TV SCREEN on/off		<input type="radio"/>	
EVF display		<input type="radio"/>	
Side panel light		<input type="radio"/>	
Zero set memory		<input type="radio"/>	

# Screen Displays

## Hiding the Displays on the Camcorder Screen

You can hide the displays on the screen to have a clear screen for playback.



### MENU

( 24)



Open the menu and select **[DISPLAY SETUP/ [speech bubble icon]]**. Select **[DISPLAYS]**, set it to **[OFF <PLAYBK>]** and close the menu.

- Warning messages still appear, and the data code appears if turned on.
- Tape operation displays appear for 2 seconds.

## Hiding/Showing the Displays on the TV Screen

When you connect a TV for recording, you can select to hide the camcorder displays on the TV screen. For playback, you can show the camcorder displays on the TV screen.



### MENU

( 24)



Open the menu and select **[DISPLAY SETUP/ [speech bubble icon]]**. Select **[TV SCREEN]**, set it to **[OFF]** and close the menu.

The displays disappear from the TV screen.



### MENU

( 24)



Open the menu and select **[DISPLAY SETUP/ [speech bubble icon]]**. Select **[TV SCREEN]**, set it to **[ON]** and close the menu.

The displays appear on the TV screen.

## Screen Displays during Recording

See also [32](#).

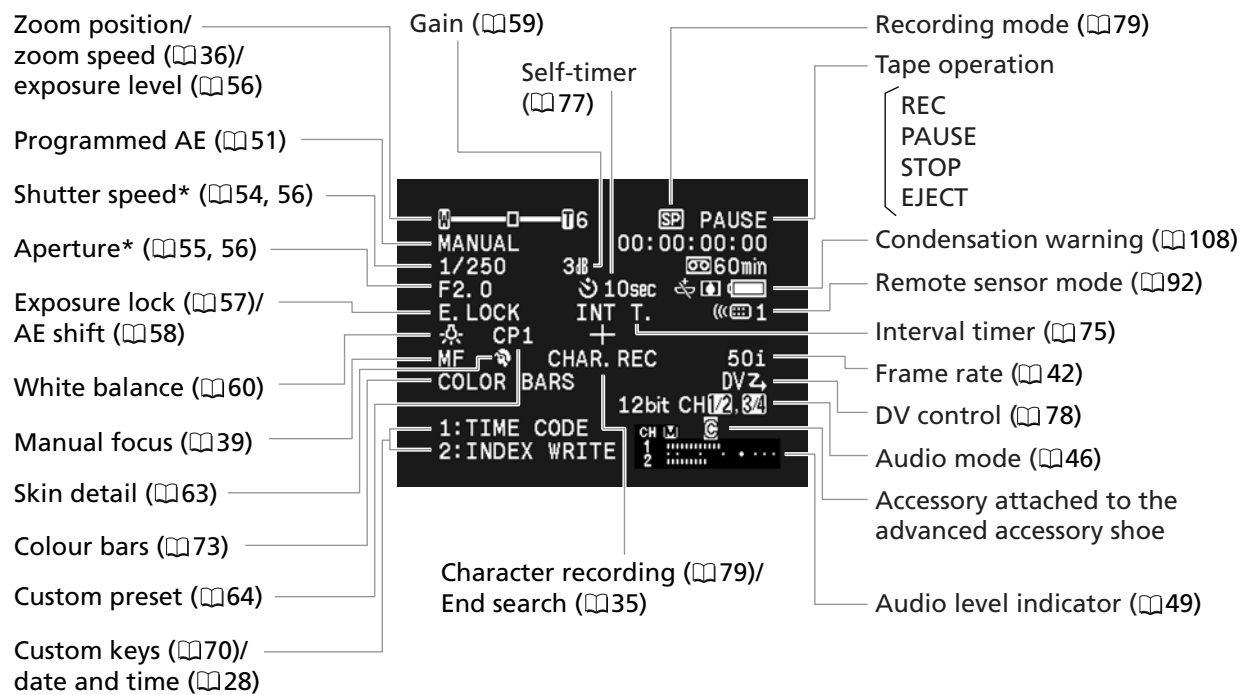

\* In Manual mode.

# Screen Displays during Playback

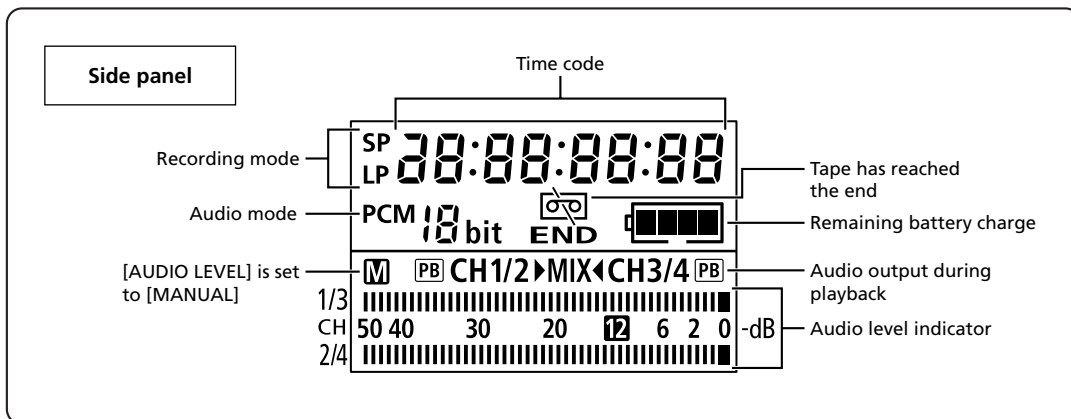
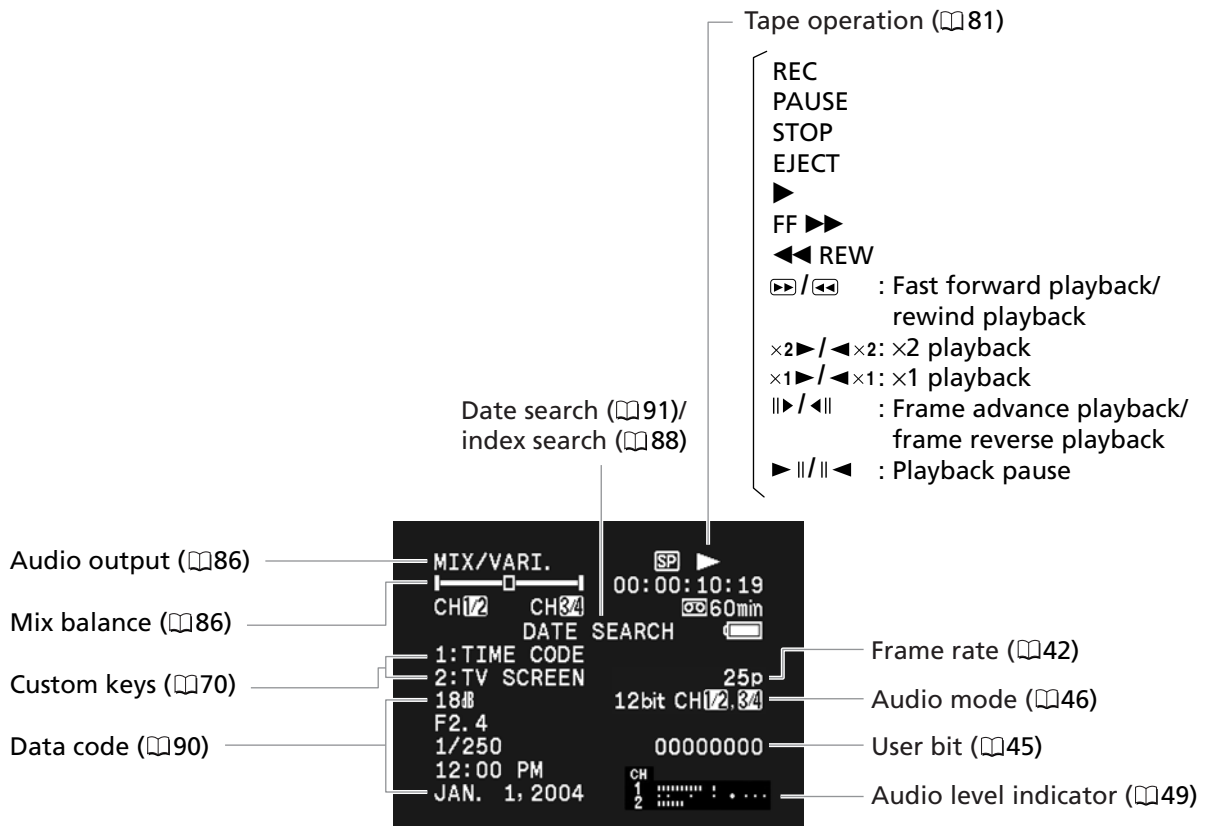



# List of Messages

Message	Explanation	 28
SET THE TIME ZONE, DATE AND TIME	You have not set the time zone, date and time. This message appears each time you turn the power on until you set the time zone, date and time.	28
CHANGE THE BATTERY PACK	Battery pack is exhausted. Replace or charge the battery pack.	11
THE TAPE IS SET FOR ERASURE PREVENTION	Cassette is protected. Replace the cassette or change the position of the protect switch.	110
REMOVE THE CASSETTE	Camcorder stopped operating to protect the tape. Unload and reload the cassette.	23
CHECK THE INPUT	DV cable is not connected, or the connected digital device is turned off.	95
CONDENSATION HAS BEEN DETECTED	Condensation has been detected in the camcorder.	108
TAPE END	Tape reached the end. Rewind the tape or replace the cassette.	–
HEADS DIRTY, USE CLEANING CASSETTE	Video heads are dirty. Clean the video heads.	108
ENTERING "POWER STANDBY"	Appears for 1 second when you press the STANDBY button.	31
CHECK THE LENS	Lens is not correctly mounted. Turn the lens until it clicks. If the message does not disappear, unmount and remount the lens.	20
COPYRIGHT PROTECTED PLAYBACK IS RESTRICTED	You attempted to play back a copyright protected tape.	96
COPYRIGHT PROTECTED DUBBING RESTRICTED	You attempted to dub a copyright protected tape. May also appear when an anomalous signal is received during analog line-in recording, or during analog-digital conversion of a copyright protected tape.	96

# Maintenance/Others

---

## Camcorder Handling Precautions

---

- Do not carry the camcorder by the viewfinder or the microphone.
- Do not leave the camcorder in places subject to high temperatures, such as a sun-heated car, and high humidity.
- Do not use the camcorder in places subject to magnetic or electric fields such as near the TV transmitters or portable communication devices.
- Do not point the lens or viewfinder at strong light sources. Do not leave the camcorder pointed at a bright subject.
- Do not use the camcorder in dusty or sandy places. Dust or sand getting inside the cassette or camcorder may cause damage. Dust and sand can also damage the lens. Attach the lens cap after use.
- The camcorder is not waterproof. Water, mud or salt getting inside the cassette or camcorder may cause damage.
- Be careful of heat generated by lighting equipment.
- Do not disassemble the camcorder. If the camcorder does not function properly, consult qualified service personnel.
- Handle the camcorder with care. Do not subject the camcorder to shocks or vibration as this may cause damage.
- Avoid sudden changes in temperature. Moving the camcorder rapidly between hot and cold temperatures may cause condensation to form on its internal surfaces (☞ 108).

## Storage

---

- If you do not intend to use the camcorder for a long time, store it in a place free of dust, in low humidity, and at temperatures not higher than 30 °C.
- After storage, check the functions of your camcorder to make sure that the camcorder is still working properly.

## Cleaning

---

### Camcorder Body and Lens

- Use a soft, dry cloth to clean the camcorder body and lens. Never use chemically treated cloth or volatile solvents such as paint thinner.

### LCD Screen

- Clean the LCD screen using a commercially available cleaning cloth for glasses.
- Condensation may form on the surface of the screen when the temperature changes suddenly. Wipe it with a soft dry cloth.

## Viewfinder

1. Pull up the eye cup and open the protect cover (e.g. using a flathead screwdriver).
2. Clean the glass with a cotton swab.
3. Reattach the protect cover.

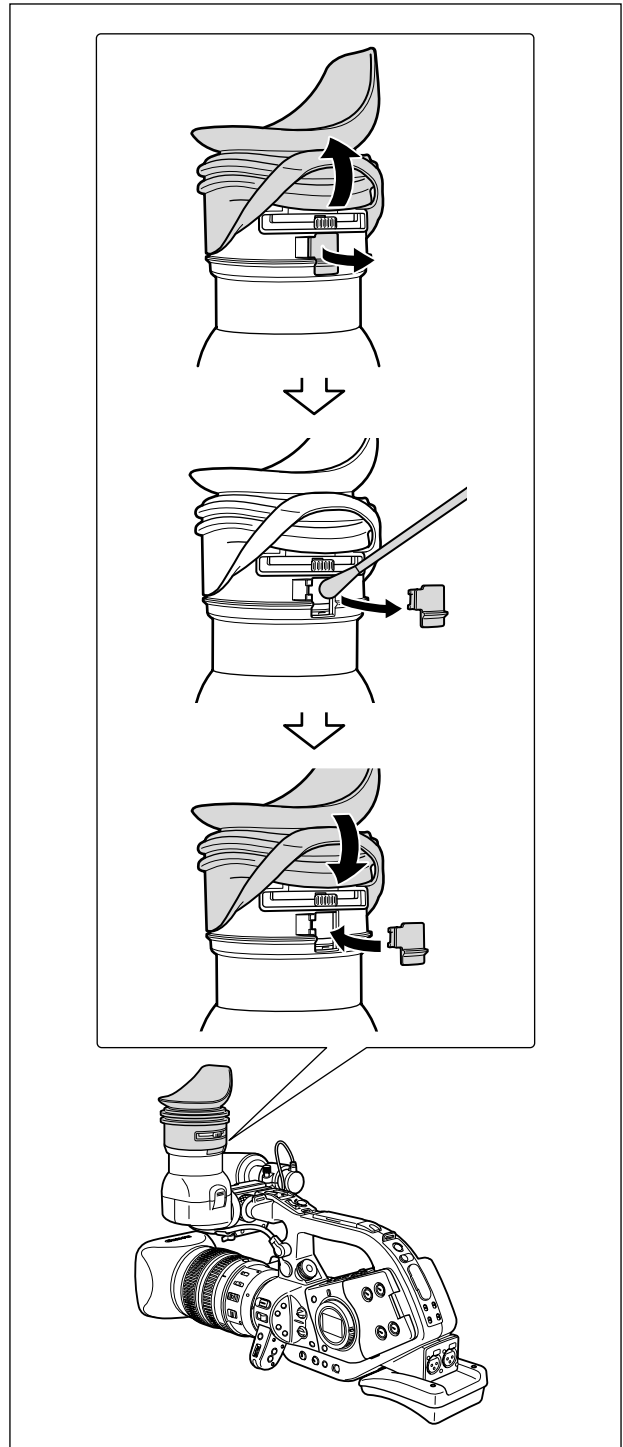

Be careful not to scratch the glass when cleaning.

## Video Heads

- When the message "HEADS DIRTY, USE CLEANING CASSETTE" appears, or when the playback picture becomes distorted, the video heads need to be cleaned.
- To maintain the best picture quality, we recommend cleaning the video heads frequently with the Canon DVM-CL Digital Video Head Cleaning Cassette or a commercially available dry cleaning cassette.
- Tapes already recorded with dirty video heads may not be played back correctly even when you clean the video heads.
- Do not use wet type cleaning cassettes as this may damage the camcorder.



## Condensation

Moving the camcorder rapidly between hot and cold temperature may cause condensation (water droplets) to form on its internal surfaces. Stop using the camcorder if condensation is detected. Continued use may damage the camcorder.

### Condensation may form in the following cases:

When the camcorder is moved from an air-conditioned room to a warm, humid place

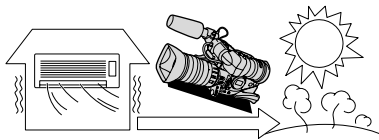

When the camcorder is left in a humid room

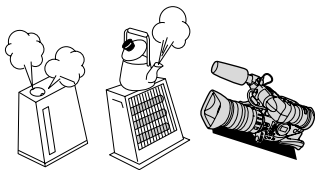

When the camcorder is moved from a cold place to a warm room

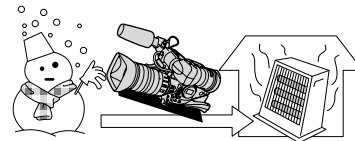

When a cold room is heated rapidly

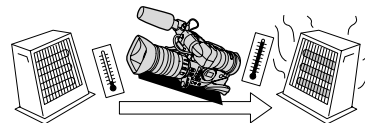

**How to avoid condensation:**

- Unload the cassette, place the camcorder in an airtight plastic bag and let it adjust to temperature changes slowly before removing it from the bag.

**When condensation is detected:**

- The camcorder stops operating, and the warning message "CONDENSATION HAS BEEN DETECTED" appears for approx. 4 seconds and "☒" starts flashing.
- If a cassette is loaded, the warning message "REMOVE THE CASSETTE" appears and "☒" starts flashing. Remove the cassette immediately and leave the cassette compartment open. Leaving the cassette in the camcorder may damage the tape.
- A cassette cannot be loaded when condensation is detected.

**Resuming use:**

- It takes about 1 hour until the water droplets evaporate. After the condensation warning stops flashing, wait for 1 more hour before resuming use.

**Battery Pack Handling Precautions****DANGER!****Treat the battery pack with care.**

- Keep it away from fire (or it might explode).
- Do not expose the battery pack to temperature higher than 60 °C. Do not leave it near a heater or inside a car in hot weather.
- Do not try to disassemble or modify it.
- Do not drop or knock it.
- Do not get it wet.

- Charged battery packs continue to discharge naturally. Therefore, charge them on the day of use, or the day before, to ensure a full charge.
- Attach the terminal cover whenever a battery pack is not in use. Contact to metallic objects may cause a short circuit and damage the battery pack.
- Dirty terminals may cause a poor contact between the battery pack and the camcorder. Wipe the terminals with a soft cloth.
- Since storing a charged battery pack for a long time (about 1 year) can shorten its lifecycle or affect performance, we recommend to discharge the battery pack fully and to store it in a dry place at temperatures no higher than 30 °C. If you do not use the battery pack for long periods, charge and discharge it fully at least once a year. If you have more than 1 battery pack, perform these precautions at the same time for all battery packs.
- Although the battery pack's operating temperature range is from 0 °C to 40 °C, the optimal range is from 10 °C to 30 °C. At cold temperatures, performance will temporarily decline. Warm it in your pocket before use.
- Replace the battery pack if the usable time after full charge diminishes substantially at normal temperatures.

## Cassette Handling Precautions

---

- Rewind tapes after use. If the tape becomes slack and damaged, it may cause picture and sound distortion.
- Return cassettes in the case and store them upright.
- Do not leave the cassette in the camcorder after use.
- Do not use spliced tapes or nonstandard cassettes as they may damage the camcorder.
- Do not use tapes that have been jammed as video heads may become dirty.
- Do not insert anything into the small holes of the cassette, or cover them with cellophane tape.
- Handle cassettes with care. Do not drop or subject them to severe impact as this may damage the cassettes.
- Rewind tapes from time to time if they are stored for a long time.
- With cassettes equipped with a memory function, metal plated terminals may become dirty with use. Clean the terminals with a cotton swab after about 10 times of loading/unloading. The memory function is not supported by the camcorder.

## Protecting Tapes from Accidental Erasure

---

To protect your recordings from accidental erasure, slide the tab on the cassette to the left. (This switch position is usually labelled SAVE or ERASE OFF.)

If you load a protected cassette in recording mode, the message "THE TAPE IS SET FOR ERASURE PREVENTION" appears for approx. 4 seconds and "Ⓜ" starts flashing. If you wish to record on that cassette, slide the tab back to the right.

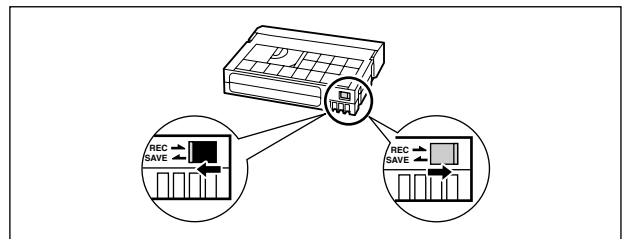

## Using the Camcorder Abroad

---

### Power Sources

You can use the compact power adapter to operate the camcorder and to charge battery packs in any country with power supply between 100 and 240 V AC, 50/60 Hz. Consult the Canon Service Centre for information on plug adapters for overseas use.

### Playback on a TV Screen

You can only play back your recordings on TVs with PAL system. The PAL system is used in the following countries/areas:

Algeria, Australia, Austria, Bangladesh, Belgium, Brunei, China, Denmark, Finland, Germany, Hong Kong Special Administrative Region, Iceland, India, Indonesia, Ireland, Italy, Jordan, Kenya, Kuwait, Liberia, Malaysia, Malta, Mozambique, the Netherlands, New Zealand, North Korea, Norway, Oman, Pakistan, Portugal, Qatar, Sierra Leone, Singapore, South Africa, Spain, Sri Lanka, Swaziland, Sweden, Switzerland, Tanzania, Thailand, Turkey, Uganda, United Arab Emirates, United Kingdom, Yemen, former Yugoslavia, Zambia.

# Troubleshooting

If you have a problem with your camcorder, refer to this checklist. Consult your dealer or a Canon Service Centre if the problem persists.

E

## Power Source

Problem	Cause	Solution	
Camcorder will not turn on.	Battery pack is not correctly attached.	Attach the battery pack correctly.	11
The camcorder switches off by itself.	Power save function has been activated.	Turn on the camcorder.	30
Viewfinder switches on and off.	Battery pack is exhausted.	Replace or charge the battery pack.	11

## Recording/Playback

Buttons will not work.	Cassette is not loaded.	Load a cassette.	23
"  " flashes on the screen.	Condensation is detected.	See reference page.	108
"REMOVE THE CASSETTE" appears on the screen.	Camcorder stopped operating to protect the tape.	Unload and reload the cassette.	23
The wireless controller will not work.	Camcorder and wireless controller are not set to the same remote sensor mode.	Change the remote sensor modes.	92
	Batteries of the wireless controller are exhausted.	Replace the batteries.	22

## Recording

Image will not appear on the screen.	The POWER dial is not set to a recording program.	Set the POWER dial to a recording program.	30
"SET THE TIME ZONE, DATE AND TIME" appears on the screen.	Time zone, date and time are not set, or the backup battery is exhausted.	Set the time zone, date and time, or replace the backup battery and reset the date and time.	28
Pressing the start/stop button will not start recording.	Cassette is not loaded.	Load a cassette.	23
	The POWER dial is not set to a recording program.	Set the POWER dial to a recording program.	30
	The lock lever on the carrying handle is activated.	Slide the lock lever to the left and deactivate it.	31
Camcorder will not focus.	Autofocus does not work on that subject.	Focus manually.	39
	Viewfinder is not adjusted.	Adjust the viewfinder with the dioptic adjustment lever.	17
	Lens is dirty.	Clean the lens.	106
The tally lamp will not light up.	[TALLY LAMP] is set to [OFF] in the menu.	Set [TALLY LAMP] to [ON].	79

Additional  
Information

## Recording

Problem	Cause	Solution	
A vertical light bar appears on the screen.	Bright light in a dark scene may cause a vertical light bar (smear) to appear. This is not a malfunction.	Record in the Av mode with F5.6–F8.0.	55
Viewfinder picture is blurred.	Viewfinder is not adjusted.	Adjust the viewfinder with the dioptic adjustment lever.	17
Audio is not recorded.	The INPUT SELECT switch is not set to the correct position.	Set the INPUT SELECT switch to the correct position.	47 48
	The REC LEVEL switch is set to M, and recording level is set too low.	Adjust the audio level correctly.	49
Audio is recorded in a very low level.	Microphone connected to the XLR terminal needs to be powered by the phantom power.	Set the +48V switch to ON.	47 48
	Microphone attenuator is turned on.	Set the MIC ATT. switch to OFF.	47 48

## Playback

Problem	Cause	Solution	
Pressing the playback button does not start playback.	Camcorder is turned off, or is not set to VCR mode.	Set the camcorder to VCR mode.	81
	Cassette is not loaded.	Load a cassette.	23
Tape is running, but image will not appear on the TV screen.	Video heads are dirty.	Clean the video heads.	108
	You attempted to play back or dub copyright protected tape.	Stop playback/dubbing.	–

## Others

Lenses with built-in image stabilizer: Detected air bubbles inside the lens.	Sometimes air bubbles may form inside the lens in airplanes or on high mountains. This is not a malfunction. The air bubbles disappear in about 1 week.	---	–
--	---	-----	---

## About the CCD

Due to the construction of the CCD, in low-light recording using the slow shutter or gaining up, small specks of light may become visible on the screen. In such cases, increase the shutter speed, reduce the gain or use an additional light source such as a video light.



# System Diagram (Availability differs from area to area)

E

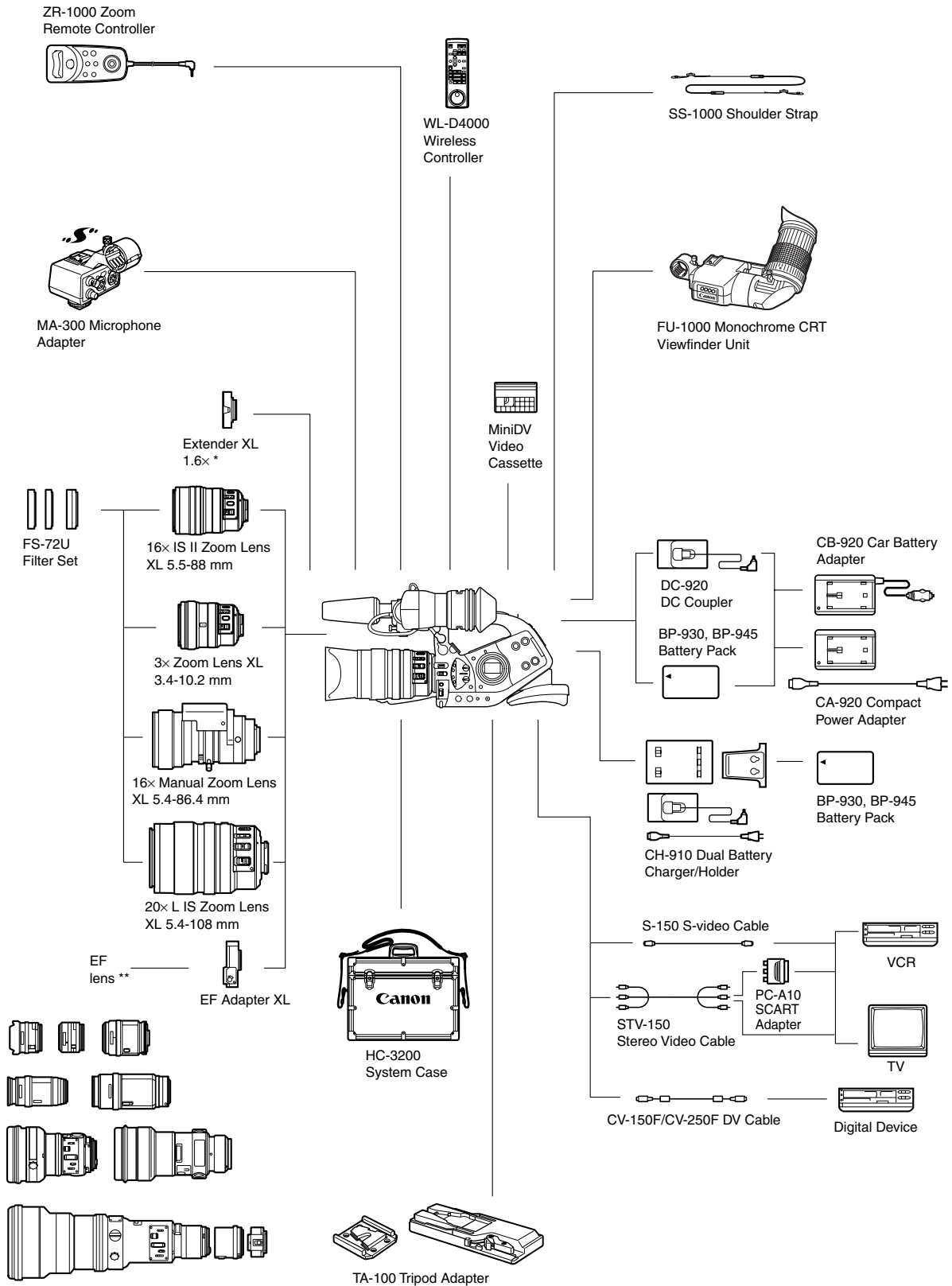

\* Can be attached to the 20x L IS, 16x IS II and 16x manual zoom lenses.  
 \*\* EF-S lenses cannot be used.

Additional  
Information

# Optional Accessories

## Use of genuine Canon accessories is recommended.

This product is designed to achieve excellent performance when used with genuine Canon accessories. Canon shall not be liable for any damage to this product and/or accidents such as fire, etc., caused by the malfunction of non-genuine Canon accessories (e.g., a leakage and/or explosion of a battery pack). Please note that this warranty does not apply to repairs arising out of the malfunction of non-genuine Canon accessories, although you may request such repairs on a chargeable basis.

### Battery Packs

The BP-930 is also available as an optional accessory.

The optional BP-945 provides 50% more recording time than the BP-930.

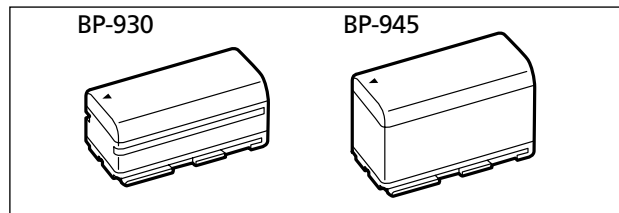

### Car Battery Adapter CB-920

Use the car battery adapter to power the camcorder or charge battery packs on the move. The car battery adapter plugs into your car's cigarette lighter socket and runs off a 12-24V DC negative ground battery.

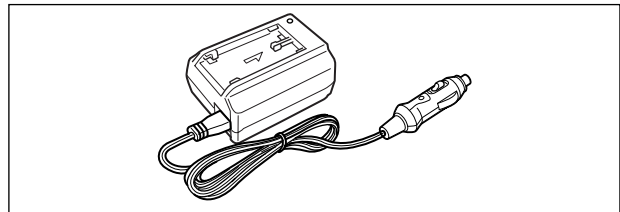

### FS-72U Filter Set

Ultraviolet, neutral density and circular polarizing filters to help you take control of difficult lighting conditions.

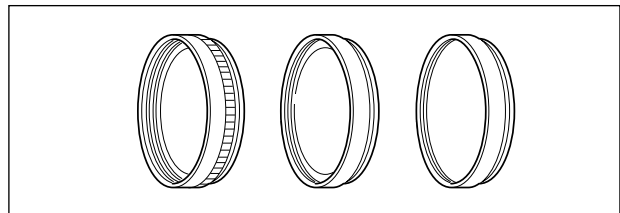

### HC-3200 System Case

A solid, lockable case that provides safe and stylish protection for the camcorder during transportation and storage.



### 3× Zoom Lens XL 3.4–10.2 mm

A super wide-angle lens that gives a range of 32.1–96.3 mm (35mm film equivalent).

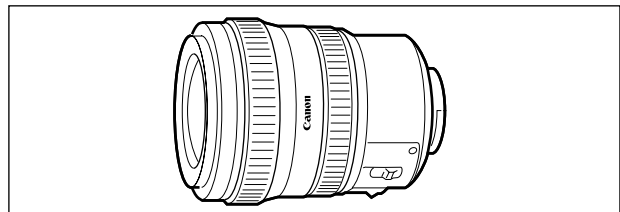

### 16× Manual Zoom Lens XL 5.4–86.4 mm

A high-resolution zoom lens with two zoom modes (manual and powered), built-in ND filter and AE functions.

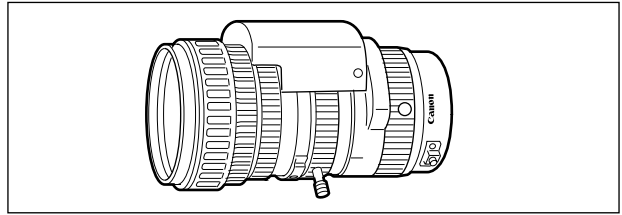

### Extender XL 1.6×

Attach this extender between a Canon XL lens and the XL2 to boost the focal length of the lens by 1.6×.

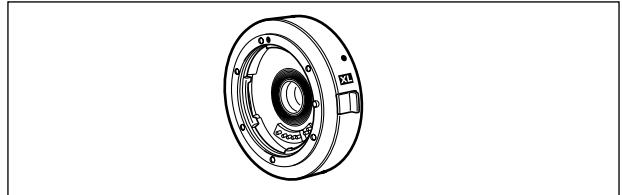

### EF Adapter XL

This allows you to attach Canon EF lenses to the XL2. The difference in size between the XL2's 1/3-inch CCD's and 35mm film means that the effective focal length of still camera lenses is multiplied by 9.4× (4:3)/7.7× (16:9).

- Consult your local service outlet to make sure there are no compatibility problems with your chosen lens.

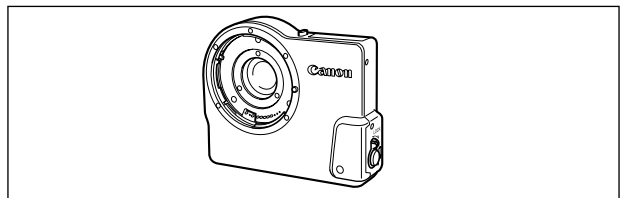

### FU-1000 Monochrome CRT Viewfinder Unit

Professional quality B&W viewfinder with a 1.5-inch CRT.

- When you use the FU-1000 with the XL2, you can supply power from the CA-920 or optional CB-920. The battery adapter supplied with the FU-1000 is not required. Attach the DC Coupler directly to the XL2, and connect it with the CA920/CB-920.

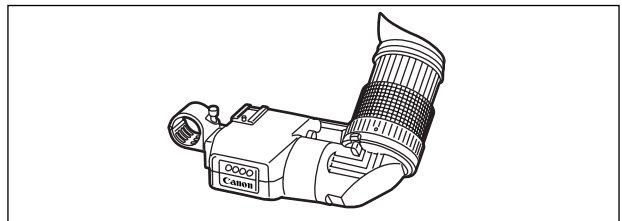

### TA-100 Tripod Adapter

The TA-100 allows you to quickly mount/unmount the XL2 on/from a tripod.

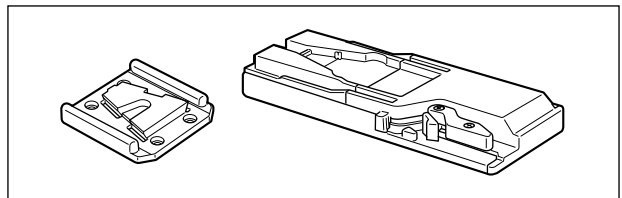

### MA-300 Microphone Adapter

With the MA-300, you can use balanced microphones on all 4 channels.

- Phantom power cannot be used with the MA-300.

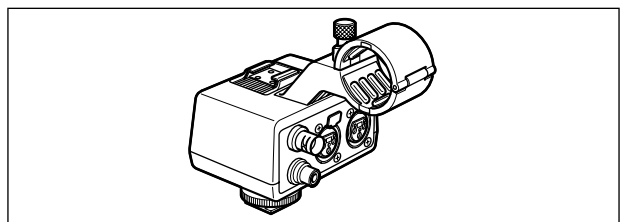

### CH-910 Dual Battery Charger/Holder

The CH-910 can charge two battery packs consecutively. You can also power the camcorder by connecting the CH-910 with charged battery packs to the camcorder. When you attach two battery packs, a battery pack can be exchanged without interrupting the power supply.

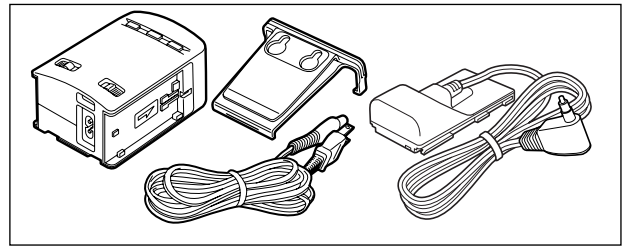

Battery Pack	Charging Time
BP-930	240 min.
BP-945	280 min.

Charging time varies according to the charging condition.

### Zoom Remote Controller ZR-1000

When this product is plugged into the LANC  terminal of a Canon camcorder, it is possible to control functions such as the start and stop of recording and the zoom and focusing functions while the camcorder is mounted on a tripod, without touching the camcorder body itself.

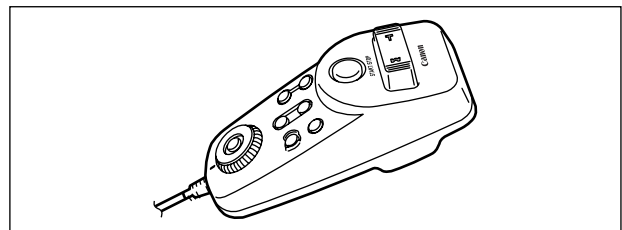

This mark identifies genuine Canon video accessories. When you use Canon video equipment, we recommend Canon-brand accessories or products bearing the same mark.

# Specifications

## XL2

### System

<b>Video Recording System</b>	2 rotary heads, helical scanning DV system (consumer digital VCR SD system), digital component recording
<b>Audio Recording System</b>	PCM digital sound: 16 bit (48 kHz/2 ch); 12 bit (32 kHz/4 ch)
<b>Television System</b>	CCIR standard (625 lines, 50 fields) PAL colour signal
<b>Image Sensor</b>	1/3-inch CCD × 3 (horizontal pixel shift), approx. 800,000 pixels Effective pixels: 4:3 approx. 410,000 pixels 16:9 approx. 550,000 pixels
<b>Tape Format</b>	Videocassettes bearing the "MiniDV" mark
<b>Tape Speed</b>	SP: 18.83 mm/s, LP: 12.57 mm/s
<b>Maximum Recording Time (80 min. cassette)</b>	SP: 80 min., LP: 120 min.
<b>Fast Forward/Rewind Time</b>	Approx. 2 min. 20 sec. (with a 60 min. cassette)
<b>Viewfinder</b>	2-inch. TFT colour, approx. 200,000 pixels, RGB delta configuration
<b>Microphone</b>	Stereo electret condenser microphone
<b>Lens mount</b>	XL interchangeable mount system
<b>AF System</b>	TTL autofocus, manual focusing with focus ring (with 20× L IS lens)
<b>White Balance</b>	Auto white balance, pre-set white balance (indoor, outdoor) or custom white balance
<b>Minimum Illumination</b>	0.8 lx (with 20× L IS lens, 50i mode, Manual mode, 1/6 shutter, F1.6, Gain 18 dB)
<b>Recommended Illumination</b>	More than 100 lx

### Input/Output Terminals

<b>S-video Terminal</b>	1 Vp-p/75 ohms (Y signal), 0.3 Vp-p/75 ohms (C signal)
<b>Video Terminal</b>	RCA jack/BNC jack 1 Vp-p/75 ohms unbalanced
<b>Audio Out Terminals</b>	RCA jack (L, R) 2 sets -10 dBv (47 kohm load, full-scale -12 dB)/3 kohms or less, unbalanced
<b>Audio In Terminals</b>	FRONT MIC: ø3.5 stereo mini jack (unbalanced), ATT: 20 dB -55 dBv (Auto mode)/600 ohms Max: -67 dBv (Manual mode, max. volume) AUDIO 1, 2: RCA jack (unbalanced) -10 dBv/47 kohms REAR: XLR jack (pin1: shield, pin2: hot, pin3: cold), ATT: 20 dB -54 dBv (Auto mode)/600 ohms Max 1: -66 dBv (Auto mode, REAR MIC Gain Up 12 dB) Max 2: -66 dBv (Manual mode, max. volume) Max 3: -78 dBv (Manual mode, max. volume, REAR MIC Gain Up 12 dB)
<b>DV Terminal</b>	Special 4-pin connector (IEEE1394 compliant)
<b>Headphone Terminal</b>	ø3.5 mm stereo mini-jack -23.5 dBv (16 ohm load)/50ohms
<b>LANC Terminal</b>	ø2.5 mm stereo mini-jack

## Power/Others

Power supply (rated)	7.2 V DC
Power consumption	7.1 W (recording with autofocus, 20× L IS Lens mounted)
Operating temperature	0 – 40 °C
Dimensions (W × H × D)	225 × 220 × 496 mm
Weight (camcorder body only) (fully loaded)	2410 g 3545 g

## Lens

Some lens specifications change as shown below when mounting on the XL2.

	Angle of view		Field size at closest focusing distance	
	Wide angle	Telephoto	Wide angle	Telephoto
20× L IS Lens	37° 54' × 28° 6' (4:3) 49° 18' × 28° 6' (16:9)	2° 0' × 1° 24' (4:3) 2° 36' × 1° 24' (16:9)	[20 mm] 45.0 × 32.5 mm (4:3) 61.2 × 32.5 mm (16:9)	[1 m] 50.1 × 36.5 mm (4:3) 66.9 × 36.5 mm (16:9)
16× IS II Zoom Lens	37° 18' × 27° 42' (4:3) 48° 30' × 27° 42' (16:9)	2° 24' × 1° 48' (4:3) 3° 12' × 1° 48' (16:9)	[20 mm] 42.8 × 30.9 mm (4:3) 58.3 × 30.9 mm (16:9)	[1 m] 56.3 × 41.1 mm (4:3) 75.2 × 41.1 mm (16:9)
3× Zoom XL Lens	57° 12' × 43° 24' (4:3) 72° 12' × 43° 24' (16:9)	20° 36' × 15° 6' (4:3) 27° 18' × 15° 6' (16:9)	[20 mm] 55.7 × 40.6 mm (4:3) 74.3 × 40.6 mm (16:9)	[0.5 m] 192.3 × 140.5 mm (4:3) 256.5 × 140.5 mm (16:9)
16× Manual Zoom Lens	37° 54' × 28° 6' (4:3) 49° 18' × 28° 6' (16:9)	2° 30' × 1° 48' (4:3) 3° 18' × 1° 48' (16:9)	[50 mm] 56.7 × 40.9 mm (4:3) 77.3 × 40.9 mm (16:9)	[1 m] 39.8 × 29.2 mm (4:3) 53.0 × 29.2 mm (16:9)

## CA-920 Compact Power Adapter

Power supply	100 – 240 V AC, 50/60 Hz
Power consumption	24 W
Rated output	Adapter: 7.2 V DC, 2.0 A Charger: 8.4 V DC, 1.5 A
Operating temperature	0°– 40 °C
Dimensions	75 × 99 × 51 mm
Weight	215 g without power cable

## BP-930 Battery Pack

Battery type	Rechargeable lithium ion battery
Rated voltage	7.2 V DC
Operating temperature	0°– 40°C
Battery capacity	3,000 mAh
Dimensions	38.2 × 39.0 × 70.5 mm
Weight	190 g

Weight and dimensions are approximate. Errors and omissions excepted. Subject to change without notice.

# Index

16:9 . . . . . 43

## A

Abroad, using the  
  camcorder . . . . . 110  
Accessories . . . . . 6, 114  
AE shift . . . . . 58  
Analog-digital converter . . . . . 97  
Analog line-in . . . . . 94  
Audio level indicator . . . . . 49  
Audio mode . . . . . 46  
Audio output . . . . . 86  
Audio reference signal . . . . . 74  
Audio recording . . . . . 46  
Auto . . . . . 51  
Autofocus . . . . . 38  
Av mode . . . . . 51

## B

Backup battery . . . . . 14  
Battery pack . . . . . 11  
Black level . . . . . 64

## C

Centre marker . . . . . 32  
Character recording . . . . . 79  
Clear scan . . . . . 69  
Colour bars . . . . . 73  
Colour gain . . . . . 64  
Colour matrix . . . . . 64  
Colour Phase . . . . . 65  
Condensation . . . . . 108  
Coring . . . . . 65  
Custom keys . . . . . 70  
Custom preset . . . . . 64

## D

Data code . . . . . 90  
Date and time . . . . . 28  
Date format . . . . . 80  
Date search . . . . . 89  
DC coupler . . . . . 12  
DV control . . . . . 78  
DV dubbing . . . . . 95  
DV terminal . . . . . 95, 99

## E

Easy recording mode . . . . . 51  
Edit search . . . . . 82  
End search . . . . . 35  
Exposure . . . . . 57

## F

Focus preset . . . . . 40  
Focusing . . . . . 39  
Frame rate . . . . . 42

## G

Gain . . . . . 59  
Gamma . . . . . 64  
Grip belt . . . . . 19  
Grip zoom . . . . . 36

## H

Handle zoom . . . . . 36  
Hue . . . . . 63

## I

Index search . . . . . 88  
Index write . . . . . 71  
Interval timer . . . . . 75

## K

Knee . . . . . 64

## L

Language . . . . . 80  
LCD panel . . . . . 17  
Lens hood . . . . . 21  
Low-angle recording . . . . . 31  
Low light mode . . . . . 52  
LP mode . . . . . 79

## M

Maintenance . . . . . 106  
Manual focus . . . . . 39  
Manual mode . . . . . 51  
Master pedestal . . . . . 65  
Menu . . . . . 24  
Microphone . . . . . 18, 47  
Mix balance . . . . . 86

## N

ND filter . . . . . 41  
NR . . . . . 65

## O

Optional accessories . . . . . 114

## P

Playback . . . . . 81  
Power adapter . . . . . 11  
Power save . . . . . 31  
Programmed AE . . . . . 51

## R

Recording . . . . . 30  
Recording programs . . . . . 51  
Record review . . . . . 34  
Record search . . . . . 34  
Remote sensor . . . . . 22

## S

Screen display . . . . . 102-104  
Self-timer . . . . . 77

Setup level . . . . . 65  
Sharpness . . . . . 65  
Shoulder strap . . . . . 19  
Shutter speed . . . . . 54  
Skin detail . . . . . 63  
Spotlight . . . . . 51  
SP mode . . . . . 79

## T

Tally lamp . . . . . 79  
Tape protection . . . . . 110  
Time code . . . . . 44  
Troubleshooting . . . . . 111  
Tv mode . . . . . 51  
TV screen . . . . . 83

## U

User Bit . . . . . 45

## V

VCR STOP . . . . . 31, 70  
Video heads . . . . . 108  
Viewfinder . . . . . 15-18

## W

Widescreen . . . . . 43  
Wireless controller . . . . . 22  
White balance . . . . . 60

## X

XL lens . . . . . 20, 114

## Z

Zebra pattern . . . . . 62  
Zero set memory . . . . . 87  
Zoom preset . . . . . 37  
Zooming . . . . . 36

# Audio Block Diagram

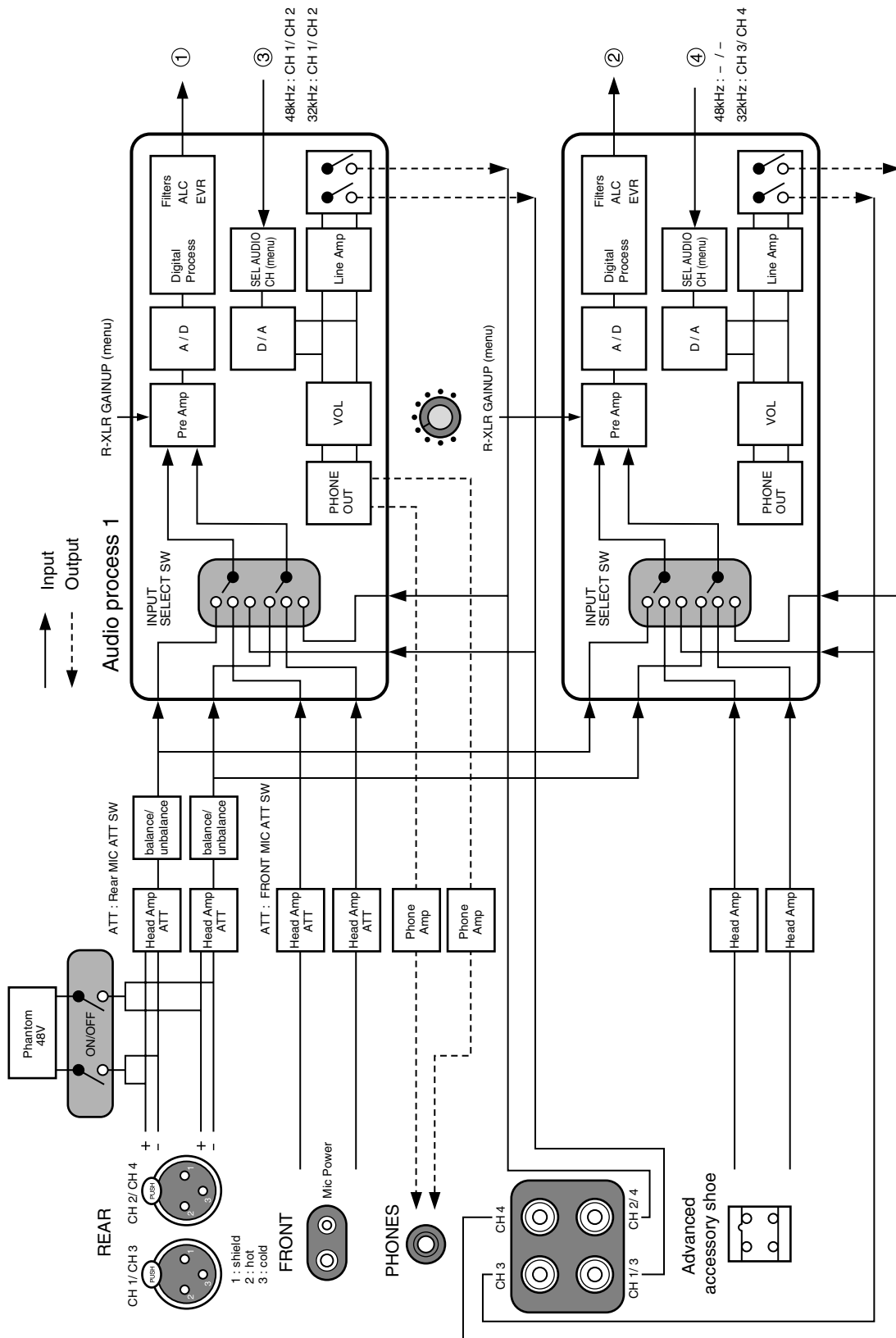



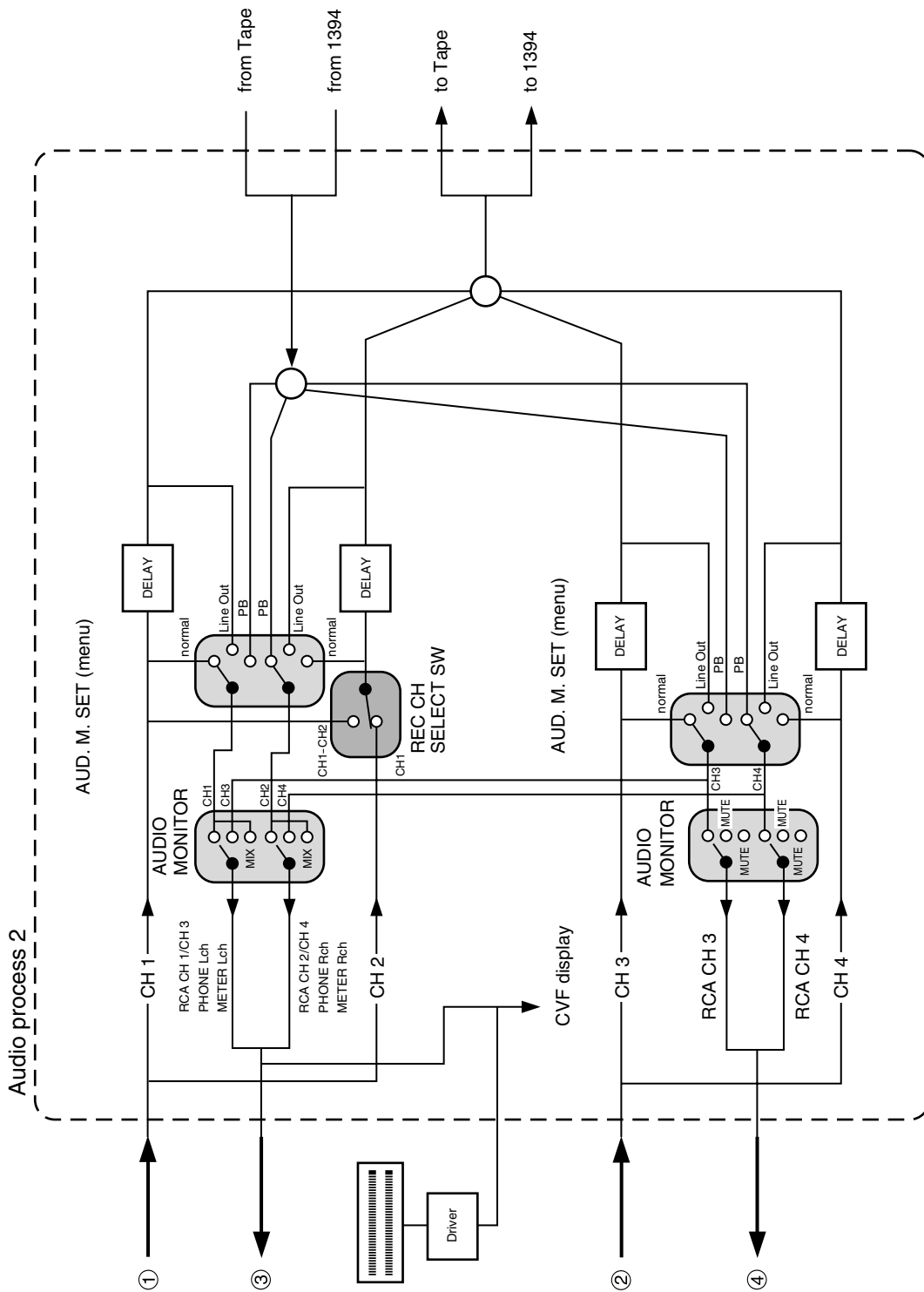

# MEMO

A series of horizontal dotted lines for writing.



**CANON INC.**

**Canon Europa N.V.**

P.O. Box 2262, 1180 EG Amstelveen, the Netherlands

**Canon UK Ltd.**

CCI Service Centre

Unit 130, Centennial Park, Borehamwood, Hertfordshire, WD6 3SE, England

Telephone 0870-241-2161

**Canon Australia Pty. Ltd.**

Info-Line: 131383

[www.canon.com.au](http://www.canon.com.au)

**Canon New Zealand Ltd.**

Customer Care: (09) 489 0470

[www.canon.co.nz](http://www.canon.co.nz)

**Canon Singapore Pte. Ltd**

1 HarbourFront Avenue, #04-01 Keppel Bay Tower, Singapore 098632

Tel: (65) 6799 8888, Fax: (65) 6799 8882

**Canon Hongkong Company Ltd**

19/F, The Metropolis Tower, 10 Metropolis Drive, Hunghom, Kowloon, Hong Kong

**Canon Latin America, Inc.**

Sales & Enquiries: 703 Waterford Way Suite 400 Miami, FL 33126 USA



Printed on 100% reused paper.