

Digital Video Camera Recorder
HANDYCAM

Operating Guide

DCR-PC1000

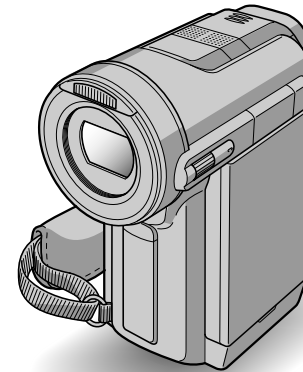

Getting Started **8**

 Recording/
Playback **20**

Using the Menu **36**

Dubbing/Editing **63**

Using a Computer **73**

Troubleshooting **86**

Additional Information **106**

<http://www.sony.net/>



Printed on 100% recycled paper using
VOC (Volatile Organic Compound)-free
vegetable oil based ink.

Printed in Japan



Mini **DV** Digital
Video
Cassette



InfoLITHIUM **A**
SERIES

© 2005 Sony Corporation

Read this first

Before operating the unit, please read this manual thoroughly, and retain it for future reference.

WARNING

To prevent fire or shock hazard, do not expose the unit to rain or moisture.

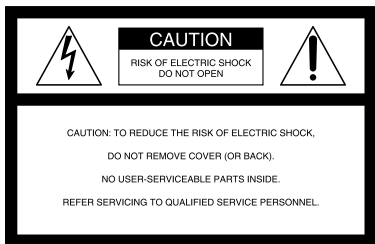

This symbol is intended to alert the user to the presence of uninsulated “dangerous voltage” within the product’s enclosure that may be of sufficient magnitude to constitute a risk of electric shock to persons.



This symbol is intended to alert the user to the presence of important operating and maintenance (servicing) instructions in the literature accompanying the appliance.

Notice

If static electricity or electromagnetism causes data transfer to discontinue midway (fail), restart the application or disconnect and connect the communication cable (USB, etc.) again.

For customers in the U.S.A. and CANADA

RECYCLING LITHIUM-ION BATTERIES

Lithium-Ion batteries are recyclable. You can help preserve our environment by returning your used rechargeable batteries to the collection and recycling location nearest you.

For more information regarding recycling of rechargeable batteries, call toll free 1-800-822-8837, or visit <http://www.rbrbc.org/>



Caution: Do not handle damaged or leaking Lithium-Ion batteries.

“Memory Stick”

This device complies with Part 15 of the FCC Rules. Operation is subject to the following two conditions:

(1) This device may not cause harmful interference, and (2) this device must accept any interference received, including interference that may cause undesired operation.

This Class B digital apparatus complies with Canadian ICES-003.

For customers in the U.S.A.

If you have any questions about this product, you may call:

Sony Customer Information Center 1-800-222-SONY (7669).

The number below is for the FCC related matters only.

Regulatory Information

Declaration of Conformity

Trade Name: SONY

Model No.: DCR-PC1000

Responsible Party: Sony Electronics Inc.

Address: 16450 W. Bernardo Dr, San Diego, CA 92127 U.S.A.

Telephone No.: 858-942-2230

This device complies with Part 15 of the FCC Rules.

Operation is subject to the following two conditions:

(1) This device may not cause harmful interference, and (2) this device must accept any interference received, including interference that may cause undesired operation.

Note

DCR-PC1000 is to be used with the Handycam Station Model DCRA-C140 and AC Power Adaptor Model AC-L200.

Owner's Record

The model and serial numbers are located on the bottom. Record the serial number in the space provided below. Refer to these numbers whenever you call upon your Sony dealer regarding this product.

Model No. DCR-PC1000

Serial No.

Model No. AC-

Serial No.

CAUTION

You are cautioned that any changes or modifications not expressly approved in this manual could void your authority to operate this equipment.

Note

This equipment has been tested and found to comply with the limits for a Class B digital device, pursuant to Part 15 of the FCC Rules. These limits are designed to provide reasonable protection against harmful interference in a residential installation. This equipment generates, uses, and can radiate radio frequency energy and, if not installed and used in accordance with the instructions, may cause harmful interference to radio communications.

However, there is no guarantee that interference will not occur in a particular installation. If this equipment does cause harmful interference to radio or television reception, which can be determined by turning the equipment off and on, the user is encouraged to try to correct the interference by one or more of the following measures:

- Reorient or relocate the receiving antenna.
- Increase the separation between the equipment and receiver.
- Connect the equipment into an outlet on a circuit different from that to which the receiver is connected.
- Consult the dealer or an experienced radio/TV technician for help.

The supplied interface cable must be used with the equipment in order to comply with the limits for a digital device pursuant to Subpart B of Part 15 of FCC Rules.

Notes on use

Your camcorder is supplied with two kinds of operations guides.

- “Operating Guide” (This manual)
- “First Step Guide” for connecting the camcorder to a computer and using the supplied software (stored on the supplied CD-ROM)

On the types of recording media you can use in your camcorder

- A mini DV cassette marked with ^{Mini} DV (mini DV cassettes with Cassette Memory are incompatible) (p. 107).
- “Memory Stick Duo” marked with **MEMORY STICK DUO, MEMORY STICK PRO DUO** (p. 108).

On using the camcorder

- Do not hold the camcorder by the following parts.



LCD panel

- The camcorder is not dustproofed, dripproofed or waterproofed. See “Maintenance and precautions” (p. 112).
- Before connecting your camcorder to another device with a USB or i.LINK cable, be sure to insert the connector plug in the proper direction. If you insert the connector plug forcibly in the wrong direction, the terminal may be damaged, or this may cause a malfunction of your camcorder.

Read this first (Continued)

- Disconnect the AC Adaptor from the Handycam Station holding both the camcorder and the DC plug.
- Be sure to slide the POWER switch up to OFF (CHG) when you insert the camcorder into the Handycam Station or remove the camcorder from it.

On the menu items, LCD panel, viewfinder, and lens

- A menu item that is grayed out is not available under the current recording or playback conditions.
- The LCD screen and the viewfinder are manufactured using extremely high-precision technology, so over 99.99% of the pixels are operational for effective use. However, there may be some tiny black points and/or bright points (white, red, blue, or green in color) that appear constantly on the LCD screen and the viewfinder. These points are normal results of the manufacturing process and do not affect the recording in any way.
- Exposing the LCD screen, the viewfinder, or the lens to direct sunlight for long periods of time may cause malfunctions.
- Do not aim at the sun. Doing so might cause your camcorder to malfunction. Take pictures of the sun only in low light conditions, such as at dusk.

On recording

- Before starting to record, test the recording function to make sure the picture and sound are recorded without any problems.
- Compensation for the contents of recordings cannot be provided, even if recording or playback is not possible due to a malfunction of the camcorder, storage media, etc.
- TV color systems differ depending on the countries/regions. To view your recordings on a TV, you need an NTSC system-based TV.

- Television programs, films, video tapes, and other materials may be copyrighted. Unauthorized recording of such materials may be contrary to the copyright laws.

On this manual

- The images of the LCD screen and the viewfinder used in this manual for illustration purposes are captured using a digital still camera, and therefore may appear different.
- The on-screen displays in each local language are used for illustrating the operating procedures. Change the screen language before using your camcorder if necessary (p. 15).

About the Carl Zeiss lens

Your camcorder is equipped with a Carl Zeiss lens, which was developed jointly by Carl Zeiss, in Germany, and Sony Corporation, and produces superior images. It adopts the MTF measurement system for video cameras and offers a quality typical of a Carl Zeiss lens. Also, the lens for your camcorder is T*-coated to suppress unwanted reflections and faithfully reproduce colors.

MTF= Modulation Transfer Function. The number value indicates the amount of light from a subject coming into the lens.

Table of Contents

Getting Started

Step 1: Checking supplied items	8
Step 2: Charging the battery pack	9
Step 3: Turning the power on and holding your camcorder firmly	13
Step 4: Adjusting the LCD panel and viewfinder	14
Step 5: Using the touch panel	15
Changing the language setting	15
Checking the screen indicators (Display guide)	15
Step 6: Setting the date and time	16
Step 7: Inserting a tape or a "Memory Stick Duo".....	17
Step 8: Selecting the aspect ratio (16:9 or 4:3) of the recording picture	19









Recording/Playback

Recording/Playback with ease (Easy Handycam).....	20
Recording	22
Playback	23
Functions used for recording/playback, etc.	24
Recording	
To use zoom	
Controlling the settings with the CAM CTRL dial/ MANUAL button (Assignable dial)	
To record sound with more presence (4CH MIC recording)	
To use the flash	
To adjust the exposure for backlit subjects	
To record in mirror mode	
To use a tripod	
Playback	
To use PB zoom	
Recording/playback	
To check the remaining battery (Battery Info)	
To turn off the operation confirmation beep	
To initialize the settings	
Other part names and functions	

Indicators displayed during recording/playback.....	28
Searching for the starting point	31
Searching for the last scene of the most recent recording (END SEARCH)	31
Searching manually (EDIT SEARCH).....	31
Reviewing the most recently recorded scenes (Rec review).....	31
Remote Commander	32
Searching quickly for a desired scene (Zero set memory).....	32
Searching for a scene by date of recording (Date search)	33
Playing the picture on a TV	34

Using the Menu

<i>Using the menu items</i>	36
Menu items.....	38
 CAMERA SET menu	40
Settings to adjust your camcorder to the recording conditions (EXPOSURE/ WHITE BAL./STEADYSHOT, etc.)	
 MEMORY SET menu.....	45
Settings for the "Memory Stick Duo"(BURST/QUALITY/IMAGE SIZE/ALL ERASE/NEW FOLDER, etc.)	
 PICT.APPLI. menu.....	48
Special effects on pictures or additional functions on recording/playback (SLIDE SHOW/PICT. EFFECT/FRAME REC, etc.)	
 EDIT/PLAY menu	53
Settings for editing or playing back in various modes (VAR.SPD PB/END SEARCH, etc.)	
 STANDARD SET menu	54
Settings while recording on a tape or other basic settings (REC MODE/ MULTI-SOUND/LCD/VF SET/DISP OUTPUT, etc.)	
 TIME/LANGU. menu.....	58
(CLOCK SET/WORLD TIME/LANGUAGE)	
Customizing Personal Menu.....	59
Using the CAM CTRL dial	61

Dubbing/Editing

Connecting to a VCR or TV	63
Dubbing to another device such as a VCR, DVD recorder, etc.....	64
Recording pictures from a VCR or TV	65
Dubbing pictures from a tape to a "Memory Stick Duo".....	66
Dubbing sound to a recorded tape	67

Deleting recorded pictures from the “Memory Stick Duo”	69
Marking images on the “Memory Stick Duo” with specific information (Image protection/Print mark)	69
Printing recorded images (PictBridge compliant printer)	70
Jacks to connect external devices	72

Using a computer

Before referring to the “First Step Guide” on your computer	73
Installing the software and “First Step Guide” on a computer	75
Viewing “First Step Guide”	80
Creating a DVD (Direct Access to “Click to DVD”)	81
Connecting an analog VCR to the computer via your camcorder (Signal convert function)	84

Troubleshooting

Troubleshooting	86
Warning indicators and messages	101

Additional Information

Using your camcorder abroad	106
Usable cassette tapes	107
About the “Memory Stick”	108
About the “InfoLITHIUM” battery pack	110
About i.LINK	111
Maintenance and precautions	112
Specifications	116
Index	118

Step 1: Checking supplied items

Make sure that you have following items supplied with your camcorder. The number in the parentheses indicates the number of that item supplied.

"Memory Stick Duo" 16MB (1) (p. 18, 108)

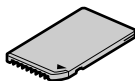

Memory Stick Duo adaptor (1) (p. 109)

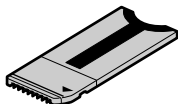

AC Adaptor (1) (p. 9)

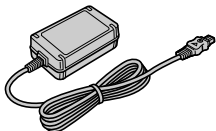

Power cord (1) (p. 9)



Handycam Station (1) (p.10)

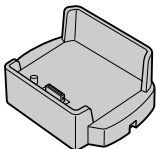

Wireless Remote Commander (1) (p. 32)



A/V connecting cable (1) (p. 34, 63)



USB cable (1) (p. 73, 84)



Shoulder Strap (1)

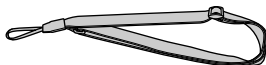

Rechargeable battery pack NP-FA50 (1) (p. 9, 110)

CD-ROM "Picture Package Ver.1.7" (1) (p. 73)

Operating Guide (This manual) (1)

A button-type lithium battery is already installed.

Step 2: Charging the battery pack

You can charge the “InfoLITHIUM” battery pack (A series) (p. 110) after attaching it to your camcorder.

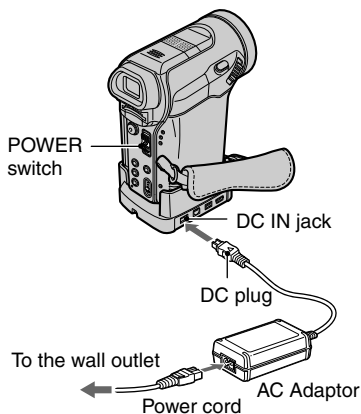

- 1** Slide the battery cover in the direction of the arrow .

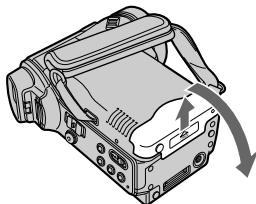

- 2** Insert the battery pack to the end with the ▲ mark facing outwards.

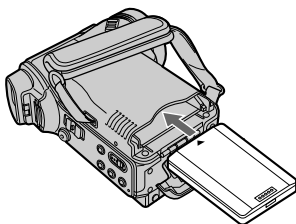

- 3** Close the battery cover.

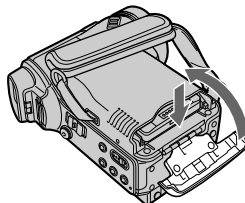

Be sure to close the cover completely.

Step2:Charging the battery pack (Continued)

- 4** Slide the **POWER** switch up to **(CHG) OFF**. (The default setting.)

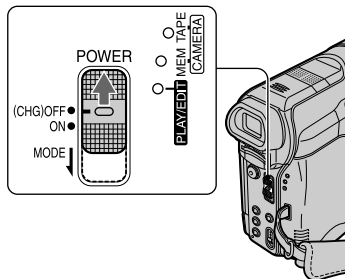

- 5** Connect the **AC Adaptor** to the **DC IN** jack on the Handycam Station. Be sure that the **▲** mark on the DC plug is facing up.

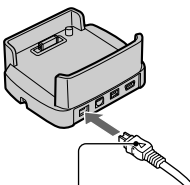

The ▲ mark faces up.

- 6** Connect the power cord to the **AC Adaptor** and the wall outlet.

- 7** Insert the camcorder into the Handycam Station securely.

Be sure to insert the camcorder to the end.

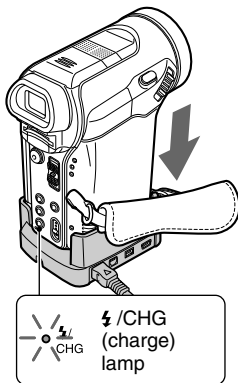

The CHG (charge) lamp lights up and charging starts. The CHG (charge) lamp turns off when the battery pack is fully charged.

- When inserting the camcorder into the Handycam Station, close the DC IN jack cover on the camcorder.

To charge the battery pack using the AC Adaptor

Slide the POWER switch up to (CHG)OFF. Then connect the AC Adaptor directly to the DC IN jack on the camcorder.

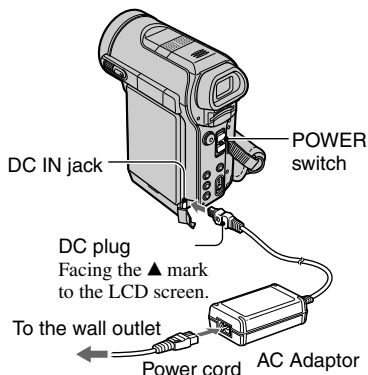

To remove your camcorder from the Handycam Station

Turn off the power, then remove the camcorder from the Handycam Station holding both your camcorder and the Handycam Station.

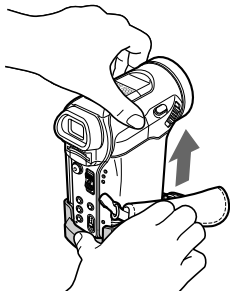

To remove the battery pack

Slide the POWER switch up to (CHG)OFF. Then open the battery cover to remove the battery pack.

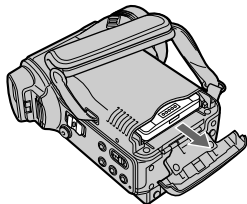

When storing the battery pack

Fully discharge the battery before storing it for an extended period (p. 110).

To use an outside power source

You can operate your camcorder using the power from the wall outlet by making the same connections as you do when charging the battery pack. The battery pack will not lose its charge in this case.

Step2:Charging the battery pack (Continued)

Charging time

Approximate time (min.) required when you fully charge a fully discharged battery pack.

Battery pack	Charging time
NP-FA50 (supplied)	125
NP-FA70	155

Recording time

Approximate time (min.) available when you use a fully charged battery pack.

Battery pack	Continuous recording time*	Typical recording time*
NP-FA50 (supplied)	80	45
	85	45
	90	50
NP-FA70	150	85
	165	90
	170	95

* Top: When the LCD backlight turns on.

Middle: When the LCD backlight turns off.

Bottom: Recording time when recording with the viewfinder while the LCD panel is closed.

- Typical recording time shows the time when you repeat recording start/stop, turning the power on/off and zooming.

Playing time

Approximate time (min.) available when you use a fully charged battery pack.

Battery pack	LCD panel opened*	LCD panel closed
NP-FA50 (supplied)	115	140
NP-FA70	215	260

* When the LCD backlight turns on.

On the battery pack

- Before changing the battery pack, slide the POWER switch up to (CHG) OFF.
- The CHG (charge) lamp flashes during charging, or the battery information (p. 26) will not be correctly displayed under the following conditions.
 - The battery pack is not attached correctly.
 - The battery pack is damaged.
 - The battery pack is fully discharged. (For Battery Info only.)
- The power will not be supplied from the battery as long as the AC Adaptor is connected to the DC IN jack of your camcorder or the Handycam Station, even when the power cord is disconnected from the wall outlet.

On the charging/recording/playback time

- Times measured with the camcorder at 77 °F (25 °C) . (50 °F to 86 °F (10 to 30 °C) is recommended.)
- The recording and playback time will be shorter when you use your camcorder in low temperatures.
- The recording and playback time will be shorter depending on the conditions under which you use your camcorder.

On the AC Adaptor

- Use the nearby wall outlet when using the AC Adaptor. Disconnect the AC Adaptor from the wall outlet immediately if any malfunction occurs while using your camcorder.
- Do not use the AC Adaptor placed in a narrow space, such as between a wall and furniture.
- Do not short-circuit the DC plug of the AC Adaptor or battery terminal with any metallic objects. This may cause a malfunction.

PRECAUTION

- Even if your camcorder is turned off, AC power (house current) is still supplied to it while connected to the wall outlet via the AC Adaptor.

Step 3: Turning the power on and holding your camcorder firmly

To record or play back, slide the POWER switch repeatedly to turn on the respective lamp.

When using it for the first time, the [CLOCK SET] screen appears (p. 16).

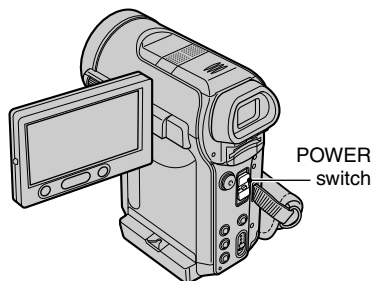

- 1 Slide the POWER switch repeatedly in the direction of the arrow to turn on the respective lamp.

The lens cover opens automatically when the POWER switch is set to CAMERA-TAPE or CAMERA-MEMORY.

If the POWER switch is set to (CHG) OFF, slide it down while pressing the green button.

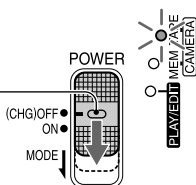

Lamps that light up

CAMERA-TAPE: To record on a tape.

CAMERA-MEMORY: To record on a "Memory Stick Duo."

PLAY/EDIT: To play or edit pictures.

- When you slide the POWER switch from (CHG) OFF to CAMERA-TAPE or CAMERA-MEMORY, the current date and time will be displayed on the LCD screen for about 5 seconds.

- 2 Hold the camcorder correctly.

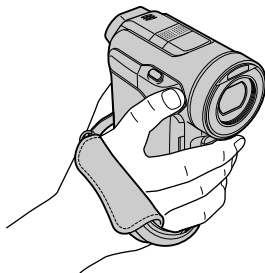

- 3 Ensure a good grip, then fasten the Strap Belt.

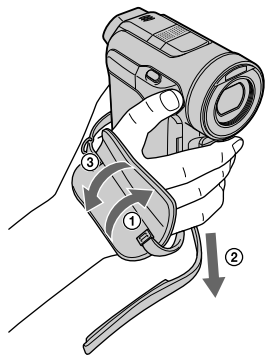

To turn off the power

Slide the POWER switch up to (CHG)OFF.

- At the time of purchase, the power will be set to turn off automatically if you leave your camcorder without any operation attempted for approximately 5 minutes, to save battery power. ([A.SHUT OFF], p. 58).

Step 4: Adjusting the LCD panel and viewfinder

The LCD panel

Open the LCD panel 90 degrees to the camcorder (①), then rotate it to the best angle to record or play (②).

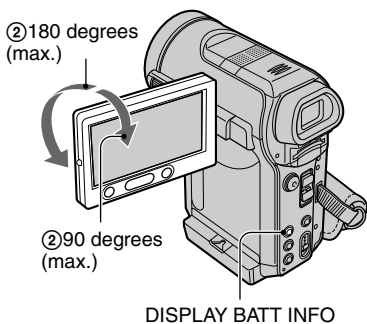
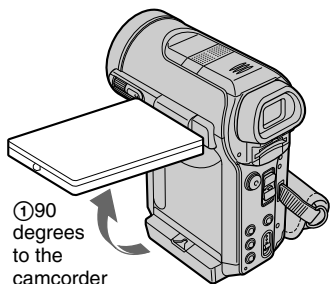

- Do not press the buttons under the LCD frame accidentally when you open or adjust the LCD panel.
- If you rotate the LCD panel 180 degrees to the lens side from the status ①, you can close the LCD panel with the LCD screen facing out. This is convenient during playback operations.
- When closing the LCD panel, rotate the LCD panel in the horizontal position as illustrated in ①, and then close the LCD panel facing inward.

To turn off the LCD backlight to make the battery last longer

Press and hold DISPLAY BATT INFO for a few seconds until \square_{OFF} appears.

This setting is practical when you use your camcorder in bright conditions or where you want to save battery power. The recorded picture will not be affected by the setting. To turn on the LCD backlight, press and hold DISPLAY BATT INFO for a few seconds until \square_{OFF} disappears.

- See [LCD BRIGHT] (p. 55) to adjust the brightness of the LCD screen.

The viewfinder

You can view images using the viewfinder with the LCD panel closed. The battery will last longer than when using the LCD panel.

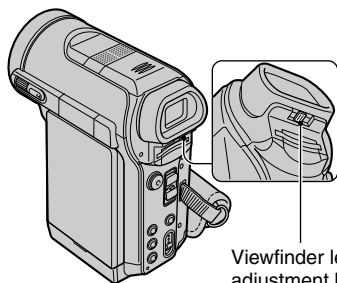

Move it until the picture is clear.

- You can adjust the brightness of the viewfinder backlight by selecting [LCD/VF SET] - [VF B.LIGHT] (p. 55).
- You can adjust manually with the CAM CTRL dial the [EXPOSURE] setting using the viewfinder (p. 40).

Step 5: Using the touch panel

You can play back recorded pictures (p. 23), or change the settings (p. 36) using the touch panel.

Place your hand on the rear side of the LCD panel to support it. Then, touch the buttons displayed on the screen.

Touch the button on the LCD screen.

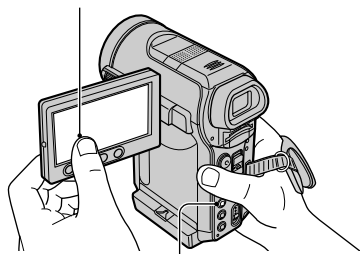

DISPLAY BATT INFO

- Perform the same actions as explained above when you press the buttons under the LCD frame.
- Be careful not to press buttons under the LCD frame accidentally while using the touch panel.

To hide the screen indicators

Press DISPLAY BATT INFO to toggle the screen indicators (such as time code, etc.) on or off.

Changing the language setting

You can change the on-screen displays to show messages in a specified language. Select the screen language in [LANGUAGE] on the  (TIME/LANGU.) menu (p. 36, 58).

Checking the screen indicators (Display guide)

You can easily check the meaning of each indicator that appears on the LCD screen.

1 Touch [P-MENU].

Touch [MENU] during Easy Handycam operation (p. 20).

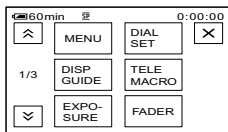

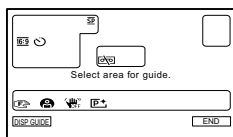

2 Touch [DISP GUIDE].



The indicators vary depending on the settings.

3 Touch the area including the indicator that you want to check.

The meanings of the indicators in the area are listed on the screen. If you cannot find the indicator you want to check, touch / to toggle. When you touch , the screen returns to the area selecting display.

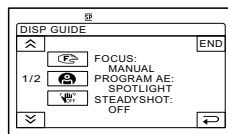

To finish the operation

Touch [END].

Step 6: Setting the date and time

Set the date and time when using this camcorder for the first time. If you do not set the date and time, the [CLOCK SET] screen appears every time you turn on your camcorder or change the POWER switch position.

- If you do not use your camcorder for **about 3 months**, the built-in rechargeable battery gets discharged and the date and time settings may be cleared from the memory. In that case, charge the rechargeable battery and then set the date and time again (p. 114).

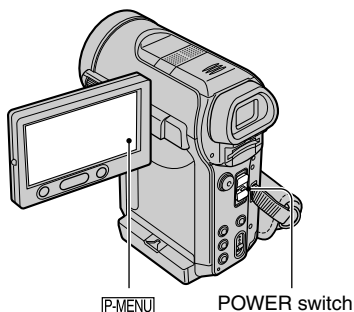

Skip to step 4 when you set the clock for the first time.

- 1 Touch **P-MENU** → **[MENU]**.

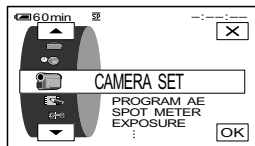

- 2 Select **(TIME/LANGU.)** menu with **▲/▼**, then touch **OK**.

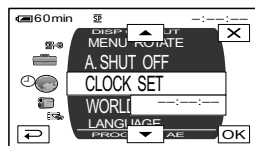

- 3 Select **[CLOCK SET]** with **▲/▼**, then touch **OK**.

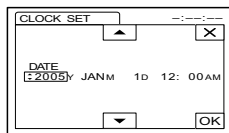

- 4 Set **[Y]** (year) with **▲/▼**, then touch **OK**.

You can set any year up to the year 2079.

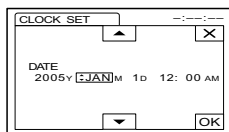

- 5 Set **[M]** (month), **[D]** (day), hour and minute, then touch **OK**.

The clock starts.

For midnight, set it to 12:00 AM.

For midday, set it to 12:00 PM.

Step 7: Inserting a tape or a “Memory Stick Duo”

Cassette tape

You can use mini DV ^{Mini} DV cassettes only (p. 107).

- The recordable time varies depending on [RECORD MODE] (p. 54).

- 1** Slide and hold the  OPEN/
▲EJECT lever in the direction of
the arrow and open the lid.

 OPEN/▲EJECT lever

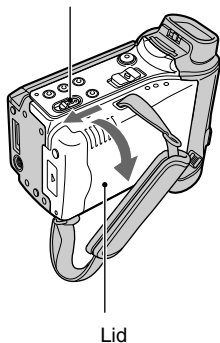

The cassette compartment automatically comes out and opens up.

- 2** Insert a cassette with its window facing outwards, then press  PUSH.

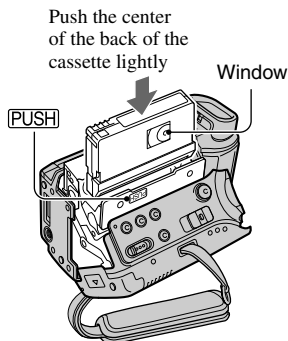

The cassette compartment automatically slides back in. Do not force the cassette into the compartment. This may cause a malfunction.

- 3** Close the lid.

To eject the cassette

Open the lid following the same procedure as described in Step 1 and remove the cassette.

Step 7: Inserting a tape or a “Memory Stick Duo” (Continued)

“Memory Stick Duo”

You can use only a “Memory Stick Duo” marked with **MEMORY STICK DUO** or **MEMORY STICK PRO DUO** (p. 108).

- The number and time of recordable pictures varies depending on the image quality or the image size. For details, see page 45.

Insert the “Memory Stick Duo” into the “Memory Stick Duo” slot in the right direction until it clicks.

Access lamp

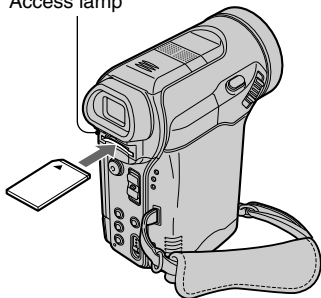

- If you force the “Memory Stick Duo” into the slot in the wrong direction, the “Memory Stick Duo,” the “Memory Stick Duo” slot, or image data may be damaged.

To eject a “Memory Stick Duo”

Lightly push the “Memory Stick Duo” in once.

- When the access lamp is lit or flashing, your camcorder is reading/writing data. Do not shake or knock your camcorder, turn the power off, eject the “Memory Stick Duo,” or remove the battery pack. Otherwise, image data may be damaged.
- Caution that the “Memory Stick Duo” might pop up and drop off.

Step 8: Selecting the aspect ratio (16:9 or 4:3) of the recording picture

By recording in the 16:9 (wide) mode, you can enjoy wide-angle, high-quality pictures.

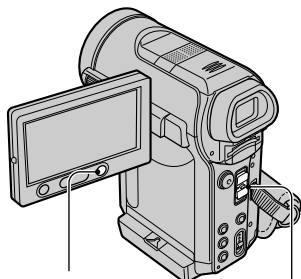

- If you intend to view pictures on a wide TV, recording in the 16:9 (wide) mode is recommended.



WIDE SELECT button

POWER switch

Recording a moving picture or still image on the "Memory Stick Duo"

- ① Set the POWER switch to CAMERA-MEMORY.
The aspect ratio of the picture switches to 4:3.
- ② Press WIDE SELECT to select the desired screen aspect ratio.
 - Still images will be fixed to image size 1920 × 1080 () in the 16:9 (wide) mode. In the 4:3 mode, you can select up to 1920 × 1440 ()
 - If you record movies (MPEG MOVIE EX) in the 16:9 (wide) mode, black bands appear at the top and bottom of the picture when they are played back.
 - For the number of recordable pictures, see page 46.

Selecting the aspect ratio for recording movies on a tape

Be sure to set the POWER switch to CAMERA-TAPE.

Press **WIDE SELECT** repeatedly to select the desired screen aspect ratio.

16:9*



4:3*



* When viewing on the LCD screen. It may be different in the viewfinder.

- If you play back a picture on TV, set [TV TYPE] for playback in the aspect ratio of the TV (p. 34).
- When viewing pictures recorded in 16:9 aspect ratio with [TV TYPE] set to [4:3], pictures may appear rough depending on the subject (p. 34).



Recording/Playback with ease (Easy Handycam)

With this Easy Handycam operation, most of the camera settings are automatically adjusted optimally, which frees you from detailed adjustment. Since only basic functions become available and screen font size increases for easy viewing, even first time users can enjoy easy operation. Go through the procedures described in steps 1 to 8 (p. 8 to 19) before operation.

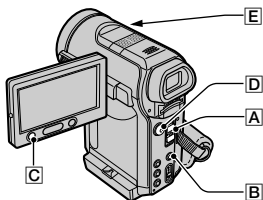

Recording with ease

1 Slide the POWER switch **A** in the direction of the arrow repeatedly to turn on the respective lamp to select a recording medium.

Recording movies : Light up the CAMERA-TAPE lamp.

Recording still images : Light up the CAMERA-MEMORY lamp.

If the POWER switch **A** is set to (CHG) OFF, slide it down while pressing the green button.

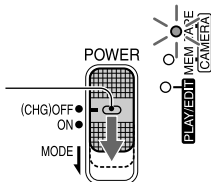

2 Press EASY **B**.



The EASY lights up in blue.

Easy Handycam
operation
ON.

3 Start recording.

Movies

Press REC START/STOP **C** or **D**.

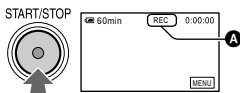

The indicator **(A)** changes [STBY] to [REC].

To stop recording, press **C** (or **D**) again.

Still images (4:3)

Press PHOTO **E**.

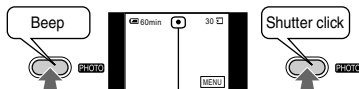

Flashing → Lights up

Press and hold lightly to adjust the focus.

Press fully to record.

When disappears, the image has been recorded.

Playing back with ease

1 Slide the POWER switch **A** in the direction of the arrow repeatedly to turn on the PLAY/EDIT lamp.

2 Press EASY **B**.





The EASY lights up in blue.

Easy Handycam
operation
ON.

3 Start playing back.

Movies

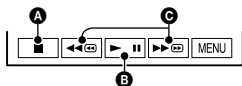

Touch , then touch  to start playback.

Slow playback  is available on the Remote Commander.



- A** Stop
- B** Play/Pause toggles as you touch it
- C** Rewind/Fast forward

Still images

Touch  →  /  to select a picture.

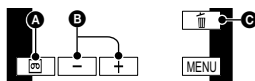

- A** Tape playback
- B** Previous/Next
- C** Delete (p. 69)

To cancel Easy Handycam operation

Press EASY **B** again.

The EASY lamp turns off and all the settings are returned to the previous situation.

- During Easy Handycam operation, the following buttons are unavailable, since the items are set automatically.
 - CAM CTRL dial
 - MANUAL button
 -  (flash) button
 - BACK LIGHT button
 - DISPLAY BATT INFO button (when kept pressing)

- WIDE SELECT button (in the CAMERA-MEMORY mode)
- PHOTO button (in the CAMERA-TAPE mode)
- The recording mode for tape and the image quality and size for “Memory Stick Duo” return to the default settings.
- If you touch [MENU], adjustable items will be displayed. Items not displayed return to the default settings (p.38).
- [Invalid during Easy Handycam operation] appears if operations not available during Easy Handycam are attempted.

Recording

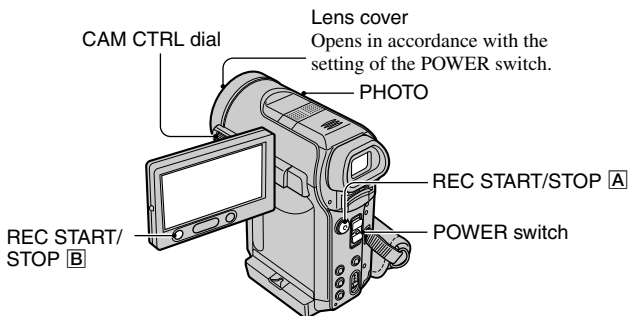

1 Slide the **POWER** switch in the direction of the arrow repeatedly to turn on the respective lamp to select a recording medium.

To record on a tape, light up the CAMERA-TAPE lamp.

To record on a “Memory Stick Duo,” light up the CAMERA-MEMORY lamp.

If the **POWER** switch is set to (CHG) OFF, slide it down while pressing the green button.

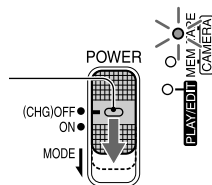

2 Start recording.

Movies

Press **REC START/STOP [A]** (or **[B]**).



The indicator **(A)** changes [STBY] (tape only) to [REC].

- The sound of a movie (MPEG MOVIE EX) recorded on a “Memory Stick Duo” will be monaural.

Still images

Press and hold **PHOTO** lightly to adjust the focus **(A)**, then press it fully **(B)**.

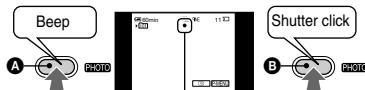

Flashing → Lights up

A shutter sound is heard. When **||||** disappears, the image has been recorded.

To stop movie recording

Press **REC START/STOP** again.

- You can record a still image on a “Memory Stick Duo,” while recording movies on a tape or in standby mode.

Still images will be fixed to image size [640 × 360] in 16:9 screen, or [640 × 480] in 4:3 screen.

To check the latest recording on a “Memory Stick Duo”

Touch . To delete the picture, touch → [YES]. Touch to return to the standby mode.

Playback

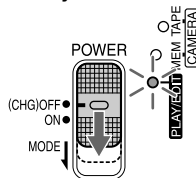

- 1 Slide the **POWER** switch in the direction of the arrow repeatedly to turn on the **PLAY/EDIT** lamp.



- 2 Start playing back.

Movies

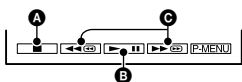

On a Tape:

Touch , then touch  to start playback.



- A Stop
 - B Play/Pause toggles as you touch it
 - C Rewind/Fast forward
- Playback automatically stops if pause is engaged for more than 3 minutes.

On a “Memory Stick Duo” :

Touch **MEMORY** →  /  to select a picture with , then touch **MPEG▶**.

Still images

Touch **MEMORY**.

The most recently recorded image is displayed.

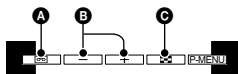





- A Tape playback
 - B Previous/Next
 - C Index screen display
- You can delete unnecessary pictures from a “Memory Stick Duo” (p. 69).
 - **MEMORY** is not displayed when a “Memory Stick Duo” is not inserted or no image files exist in it.

To adjust the volume

Rotate the **CAM CTRL** dial to adjust the volume. You can also adjust the volume on the menu (p. 54).



To search for a scene during playback

Touch and hold / during playback (Picture Search), or / while fast forwarding or rewinding the tape (Skip Scan).

- You can play back in various modes ( VAR, SPD PB), p. 53).

To display pictures on a “Memory Stick Duo” on the Index screen

Touch . Touch the picture you want to display in the single display mode.

To view pictures in other folders, touch  → **SET** → **[PB FOLDER]**, select a folder with /, then touch **OK** (p. 48).

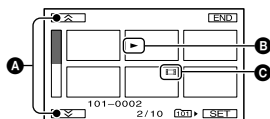

- A Previous/Next 6 pictures
- B The picture displayed before switching to the index screen.
- C Movie icon

Functions used for recording/playback, etc.

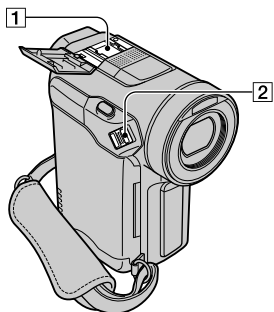

Wider range of view: (Wide angle)

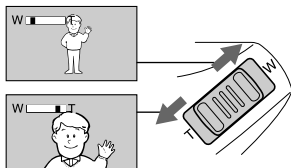

Close view: (Telephoto)

- You cannot change the zoom speed with the zoom buttons [6] under the LCD frame.
- The minimum distance required between your camcorder and the subject to get a sharp focus is about 1 cm (about 1/2 in.) for wide angle and about 80 cm (about 2 5/8 feet) for telephoto.
- You can set [DIGITAL ZOOM] if you want to zoom to a level greater than 10x.
- Be sure to keep your finger on the power zoom lever. If you move your finger off the power zoom lever, the operation sound of the power zoom lever may also be recorded.

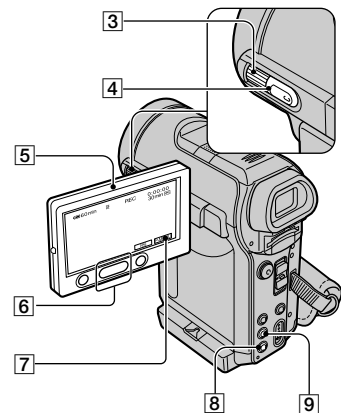

Controlling the settings with the CAM CTRL dial/MANUAL button (Assignable dial)..... [3] [4]

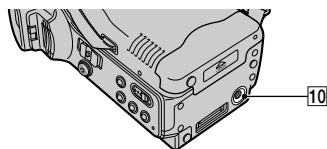
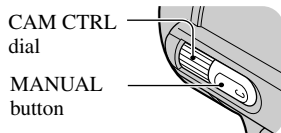

You can assign some of the camera settings to the CAM CTRL dial such as focus adjustment (default setting). See page 61 for details.

During playback, you can adjust the volume using the CAM CTRL dial (p. 23).

- At the time of purchase, the [FOCUS] (p. 42) setting is assigned to the CAM CTRL dial. If you press the MANUAL button, you can switch from the auto setting to the manual setting and adjust the focus manually.

Recording

To use zoom [2] [6]

Move the power zoom lever [2] slightly for a slower zoom. Move it further for a faster zoom.

To record sound with more presence (4CH MIC recording) 7

Connect the optional microphone (ECM-HQP1) to the Active Interface Shoe 1 (p. 72).

See [EXT SUR MIC] on page 55 for details.

To use the flash 8

Press  (flash) repeatedly to select a setting.

No indicator displayed: Automatically flashes when there is insufficient ambient light.





 (Forced flash): Always uses the flash regardless of the surrounding brightness.



 (No flash): Records without flash.

- The recommended distance to the subject when using the built-in flash is 0.3 to 2.5 m (1 to 8 feet).
- Remove any dust from the surface of the flash lamp before using it. Flash effect may be impaired if heat discoloration or dust obscures the lamp.
- The flash charge lamp flickers when charging the flash, and remains lit when the battery charge is complete.
- You can only use the flash in the CAMERA-MEMORY mode.
- If you use the flash in bright places such as when shooting a backlit subject, the flash may not be effective.
- When attaching a conversion lens (optional) or a filter (optional) to the camcorder, the flash light does not emit light.
- You can change the brightness of the flash by setting [FLASH LEVEL], or you can prevent the redden by setting [REDEYE REDUC], in [FLASH SET] (p. 43).

To adjust the exposure for backlit subjects 9

To adjust the exposure for backlit subjects, press BACK LIGHT  9 to display . To cancel the back light function, press BACK LIGHT again.

To record in mirror mode 5

Open the LCD panel  5 90 degrees to the camcorder (1), then rotate it 270 degrees to the lens side (2).

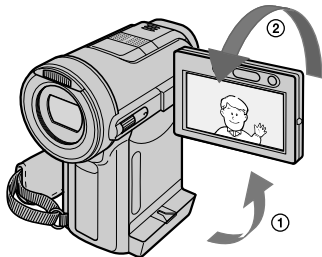

- A mirror-image of the subject appears on the LCD screen, but the picture will be normal when recorded.

To use a tripod 10

Attach the tripod (optional: the length of the screw must be less than 5.5 mm (7/32 in.) to the tripod receptacle  10 using a tripod screw.

Functions used for recording/playback, etc. (Continued)

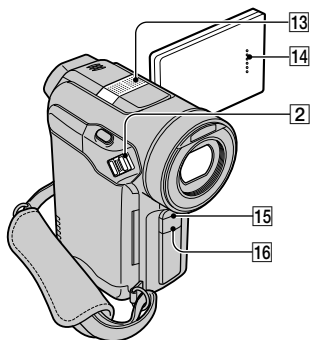
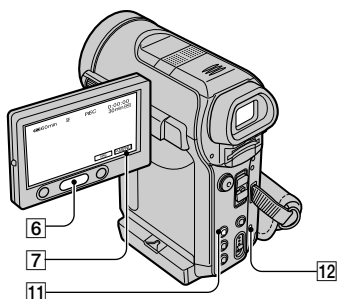

- ④ Adjust the magnification with W (Wide angle)/T (Telephoto).

To cancel, touch [END].

- You cannot change the zoom speed with the zoom buttons [6] under the LCD frame.

Recording/playback

To check the remaining battery (Battery Info) [11]

Set the POWER switch up to (CHG) OFF, then press DISPLAY BATT INFO [11]. The battery information appears for about 7 seconds. By pressing DISPLAY BATT INFO, you can view the battery information for up to 20 seconds while it is displayed.

Remaining battery (approx.)

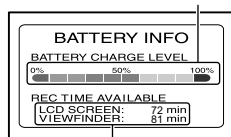

Recording capacity (approx.)

Playback

To use PB zoom [2] [6]

You can magnify pictures from about 1.1 to 5 times the original size.

Magnification can be adjusted with the power zoom lever [2] or the zoom buttons [6] under the LCD frame.

- ① Play back the picture you want to magnify.
- ② Magnify the picture with T (Telephoto).
- ③ Touch the screen at the point you want to display in the center of the displayed frame.

To turn off the operation confirmation beep [7]

See [BEEP] (p. 57) to set the operation beep.

To initialize the settings [12]

Press RESET [12] to initialize all the settings, including the setting of the date and time.

(Menu items customized on Personal Menu are not initialized.)

Other part names and functions

- 13** Internal stereo microphone
When an external microphone is connected, the audio input from the external microphone takes precedence over others.
- 14** Speaker
Sounds come out from the speaker.
• For how to adjust the volume, see page 23.
- 15** REC lamp
The REC lamp lights up in red during recording (p. 57).
- 16** Remote sensor
Point the Remote Commander (p. 32) towards the remote sensor to operate your camcorder.

Indicators displayed during recording/playback

Recording movies

In the CAMERA-TAPE mode

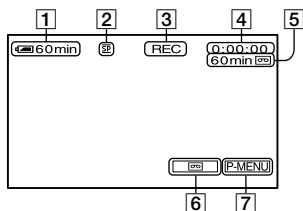

- 1 Remaining battery (approx.)
- 2 Recording mode (SF or LP) (54)
- 3 Recording status ([STBY] (standby) or [REC] (recording))
- 4 Time code (hour: minute: second: frame)/Tape counter (hour: minute: second)
- 5 Recording capacity of the tape (approx.) (57)
- 6 END SEARCH/EDIT SEARCH/Rec review display switch button (31)
- 7 Personal Menu button (36)

In the CAMERA-MEMORY mode

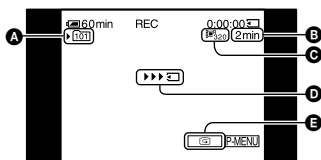

- A Recording folder (48)
- B Recording capacity (approx.)
- C Movie size (47)
- D Recording start indicator (appears for about 5 seconds)
- E Review button (22)

Recording still images

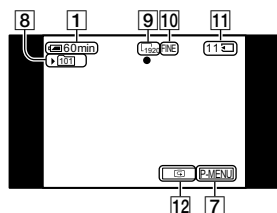

- 8 Recording folder (48)
- 9 Image size (19, 46)
- 10 Quality ([FINE] or [STD]) (45)
- 11 "Memory Stick Duo" indicator and the number of images that can be recorded (approx.)
- 12 Review button (22)

Data code during playback

The date/time data and the camera setting data will be recorded automatically. They do not appear on the screen during recording, but you can check them as [DATA CODE] during playback (p. 56).

() is a reference page.

The indicators during recording will not be recorded.

Viewing movies

On a tape

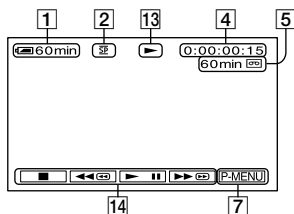

13 Tape transport indicator

14 Video operation buttons (23)

When there is a “Memory Stick Duo” inserted in the camcorder, (STOP) changes to (“Memory Stick Duo” playback) if a tape is not used for playback.

On a “Memory Stick Duo”

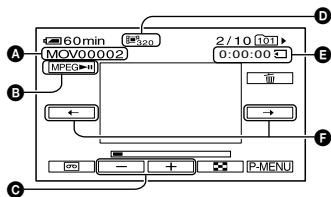

A Data file name

B Play/Pause button (23)

C Previous/Next image button (23)

D Image size (47)

E Playing time

F Previous/Next scene button

A movie file will be divided into a maximum of 60 scenes. The number of scenes divided depends on the length of the movie. After selecting a scene from which to start the playback, touch to play back.

Viewing still images

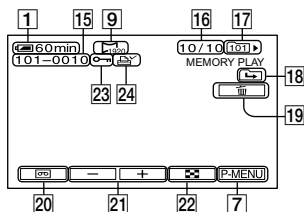

15 Data file name

16 Picture number/Total number of recorded pictures in the current playback folder

17 Playback folder (48)

18 Previous/Next folder icon

The following indicators appear when the first or last picture of the current folder is displayed and when there are multiple folders on the same “Memory Stick Duo.”

: Touch to move to the previous folder.

: Touch to move to the next folder.

: Touch / to move to either the previous or the next folder.

19 Image delete button (69)

20 Tape playback select button (23)

21 Previous/Next image button (23)

22 Index screen display button (23)

23 Image protection mark (69)

24 Print mark (70)

Indicators displayed during recording/playback (Continued)

Indicators when you made changes

You can check the [DISP GUIDE] (p. 15) to check the function of each indicator that appears on the LCD screen.

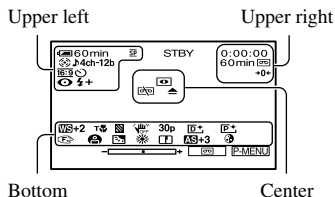

Upper left

Indicator	Meaning
	EXT SUR MIC (55)
	4CH MIC recording (55)
	AUDIO MODE (54)
	Continuous photo recording (45)
	Recording mode (54)
	Self-timer recording (44)
	WIDE SELECT (19)
	Interval photo recording (51)
	Flash light (43)
	Frame recording (51)

Upper right

Indicator	Meaning
	A/V→DV OUT (56)
	DV input (64)
	DV output (64)
	USB connection (85)
	i.LINK connection (85)
	Zero set memory (32)

	Slide show (49)
	LCD backlight off (14)

Center

Indicator	Meaning
	Color Slow Shutter (43)
	PictBridge connecting (70)
	Warning (101)

Bottom

Indicator	Meaning
	AE SHIFT (42)
	WB SHIFT (42)
	Picture effect (50)
	Digital effect (49)
	Manual focus (42)
	EXP.FOCUS (42)
	PROGRAM AE (40)
	Sharpness (41)
	Backlight (25)
	White balance (41)
	SteadyShot off (44)
	Progressive recording (44)
	Zebra (43)
	Tele macro (43)
	CAMERA COLOR (42)

Searching for the starting point

Make sure that the CAMERA-TAPE lamp lights up (p. 22).

Searching for the last scene of the most recent recording (END SEARCH)

[END SEARCH] will not work once you eject the cassette after you have recorded on the tape.

Touch  → .

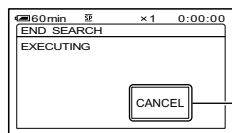

Touch here to cancel the operation.

The last scene of the most recent recording is played back for about 5 seconds, and the camcorder enters the standby mode at the point where the last recording has finished.



- [END SEARCH] will not work correctly when there is a blank section between recorded sections on the tape.
- You can also select [END SEARCH] from the menu. When the PLAY/EDIT lamp lights up, select the [END SEARCH] shortcut in Personal Menu (p. 36).

Searching manually (EDIT SEARCH)

You can search for the start point to start the next recording while viewing the pictures on the screen. The sound is not played back during the search.

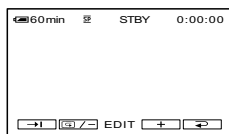
1 Touch .



2 Touch and hold  / - (to go backward) /  + (to go forward) and release it at the point where you want the recording to start.

Reviewing the most recently recorded scenes (Rec review)

You can view about 2 seconds of the scene recorded just before you stopped the tape.

Touch  → .

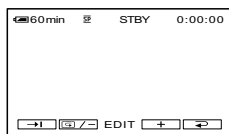

The last 2 seconds (approx.) of the most recently recorded scene are played back. Then, your camcorder is set to the standby.

Remote Commander

Remove the insulation sheet before using the Remote Commander.

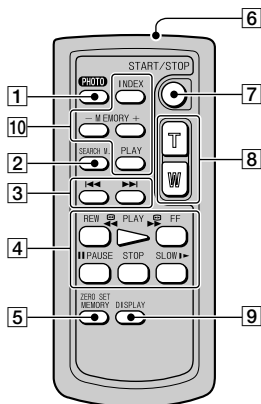
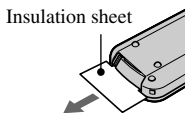

1 PHOTO (p. 22)

The on-screen image when you press this button will be recorded as a still image.

2 SEARCH M. (p. 33)



4 Video control buttons (Rewind, Playback, Fast-forward, Pause, Stop, Slow) (p. 23)

5 ZERO SET MEMORY

6 Transmitter

7 REC START/STOP (p. 22)

8 Power zoom (p. 24)

9 DISPLAY (p. 15)

10 Memory control buttons (Index, +/-, Memory playback) (p. 23)

- Aim the Remote Commander towards the remote sensor to operate your camcorder (p. 27).

- To change the battery, see page 115.

Searching quickly for a desired scene (Zero set memory)

1 During playback, press ZERO SET MEMORY **5** at a point you want to locate later on.

The tape counter is reset to “0:00:00” and +0+ appears on the screen.

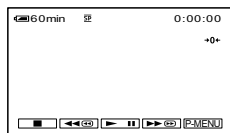

If the tape counter is not displayed, press DISPLAY **9**.

2 Press STOP **4** when you want to stop playback.

3 Press ◀REW **4**.

The tape stops automatically when the tape counter reaches “0:00:00.”

4 Press PLAY **4**.

Playback starts from the point designated “0:00:00” on the tape counter.

- There may be a discrepancy of several seconds between the time code and the tape counter.
- Zero set memory will not function correctly if there is a blank section between recorded sections on the tape.

To cancel the operation

Press ZERO SET MEMORY **5** again.

Searching for a scene by date of recording (Date search)

You can locate the point where the recording date changes.

1 Slide the **POWER** switch down to turn on the **PLAY/EDIT** lamp.

2 Press **SEARCH M.** [2].

3 Press **◀◀(previous)/▶▶(next)** [3] to select a recording date.

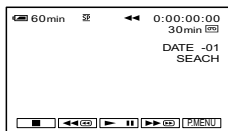

To cancel the operation

Press **STOP** [4].

- The Date search will not function correctly when there is a blank section between recorded sections on the tape.

Playing the picture on a TV

Connect your camcorder to the wall outlet using the supplied AC Adaptor for this operation (p. 11). Refer also to the instruction manuals supplied with the devices to be connected.

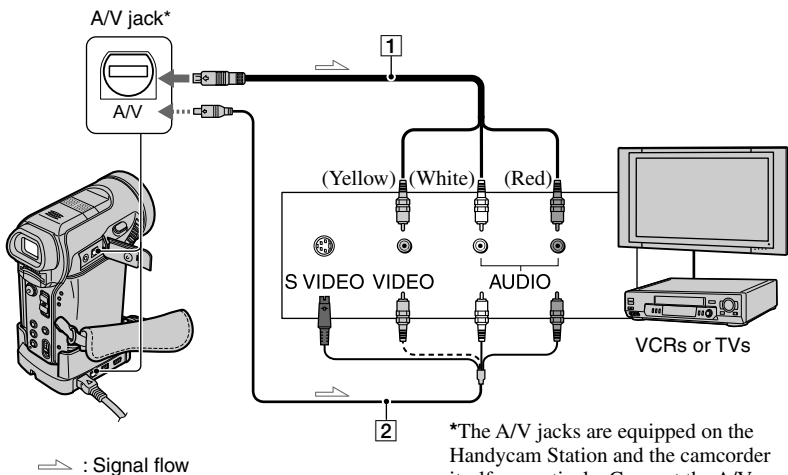

*The A/V jacks are equipped on the Handycam Station and the camcorder itself respectively. Connect the A/V connecting cable either to your camcorder or to the Handycam Station.

1 A/V connecting cable (supplied)
Connect to the input jack of the other device.

2 A/V connecting cable with S VIDEO (optional)
When connecting to another device via the S VIDEO jack, by using the A/V connecting cable with an S VIDEO cable (optional), pictures can be reproduced more faithfully than with the supplied A/V cable connection. Connect the white and red plugs (left/right audio) and S VIDEO plug (S VIDEO channel) of an A/V connecting cable (optional). In this case, the yellow (standard video) plug connection is not necessary. S VIDEO connection only will not output audio.

When your TV is connected to a VCR
Connect your camcorder to the LINE IN input on the VCR. Set the input selector on the VCR to LINE.

To set the aspect ratio according to the connected TV (16:9/4:3)

Change the setting according to the screen size of the TV you will view pictures on.

- Slide the POWER switch down to turn on the PLAY/EDIT lamp.
- Touch **[P-MENU]** → **[MENU]** → **[STANDARD SET]** → **[TV TYPE]** → **[16:9]** or **[4:3]** → **[OK]**.

- When you connect your camcorder to a TV compatible with the ID-1/ID-2 system, or via an S VIDEO jack, and play back the tape, set **[TV TYPE]** to **[16:9]**. The TV automatically switches the aspect ratio according to the playback picture. Refer also to the manual supplied with your TV.
- When you set **[TV TYPE]** to **[4:3]**, or when the picture's aspect ratio switches between 16:9 and 4:3, the image may jitter.

- On some 4:3 TVs, the still image recorded in 4:3 aspect ratio may not appear in full screen. This is not a malfunction.



- When you play back a picture recorded in 16:9 aspect ratio on a 4:3 TV not compatible with the 16:9 signal, set [TV TYPE] to [4:3].

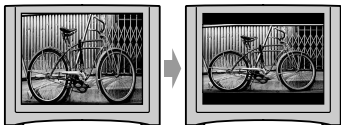

When your TV is monaural (When your TV has only one audio input jack)

Connect the yellow plug of the A/V connecting cable to the video input jack and connect the white (left channel) or the red (right channel) plug to the audio input jack of your TV or VCR.

- Do not connect A/V connecting cables to both your camcorder and the Handycam Station at the same time. The image might get disturbed.
- You can display the time code on the TV screen by setting [DISP OUTPUT] to [V-OUT/PANEL] (p. 57).

Using the menu items

Follow the instructions below to use each of the menu items listed after this page.

1 Slide the POWER switch down to turn on the respective lamp.

[CAMERA-TAPE] lamp:  settings on a tape

[CAMERA-MEMORY] lamp:  settings on a “Memory Stick Duo”

[PLAY/EDIT] lamp: settings for viewing/editing

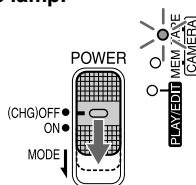

2 Touch the LCD screen to select the menu item.

Unavailable items will be grayed out.

■ To use the short-cuts of Personal Menu



On Personal Menu, short-cuts for frequently used menu items are added.

- You can customize Personal Menu as you like (p. 59).

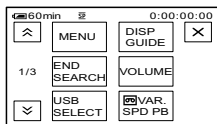
- ① Touch **P-MENU**.



- ② Touch the desired item.

If the desired item is not displayed on the screen, touch / until the item is displayed.

- ③ Select the desired setting, then touch **OK**.

■ To use menu items

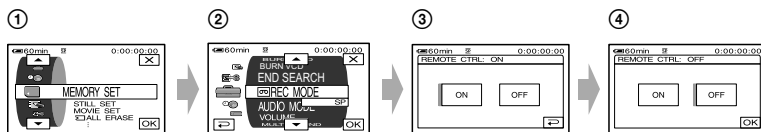

You can customize menu items that are not added to Personal Menu.



- ① Touch **P-MENU** → **[MENU]**.

The menu index screen appears.

- ② Select the desired menu.

Touch / to select the item, then touch **OK**. (The process in step ③ is the same as that in step ②.)

- ③ Select the desired item.

- You can also touch the item directly to select it.

- ④ Customize the item.

After finishing the settings, touch **OK** → **X** (close) to hide the menu screen.

If you decide not to change the setting, touch **↶** to return to the previous screen.

- You can also change the settings to [FOCUS], [EXPOSURE], [AE SHIFT] or [WB SHIFT] using the CAM CTRL dial (p. 61).
- During Easy Handycam operation, if you press [MENU] on the screen, the buttons for the menu items available for the operation are displayed.

Menu items



- The menu items available for the operation (●) differ depending on where the lit lamp for the POWER switch is positioned.

Position of lamp: **TAPE** **MEMORY** **PLAY/EDIT** **Easy Handycam**

CAMERA SET menu (p. 40)

PROGRAM AE	●	●	—	AUTO
SPOT METER	●	●	—	—
EXPOSURE	●	●	—	AUTO
WHITE BAL.	●	●	—	AUTO
SHARPNESS	●	●	—	—
AUTO SHUTTER	●	—	—	ON
AE SHIFT	●	●	—	OFF
CAMERA COLOR	●	●	—	—
WB SHIFT	●	●	—	OFF
SPOT FOCUS	●	●	—	—
FOCUS	●	●	—	AUTO
EXP.FOCUS	—	●	—	OFF
TELE MACRO	●	●	—	OFF
FLASH SET	—	●	—	⚡ ² /OFF
COLOR SLOW S	●	—	—	OFF
ZEBRA	●	●	—	OFF
HISTOGRAM	●	●	—	OFF
SELF-TIMER	●	●	—	● ^{*1}
DIGITAL ZOOM	●	—	—	OFF
STEADYSHOT	●	—	—	ON
PROGRES.REC	●	—	—	OFF
DIAL SET	●	●	—	—

MEMORY SET menu (p. 45)

STILL SET	—	●	●	OFF/FINE/L ¹⁹²⁰
MOVIE SET	—	●	●	 320
 ALL ERASE	—	—	●	●
 FORMAT	—	●	●	—
FILE NO.	—	●	●	SERIES
NEW FOLDER	—	●	●	—
REC FOLDER	—	●	●	— ²
PB FOLDER	—	—	●	— ²



PICT.APPLI. menu (p. 48)

FADER	●	—	—	OFF
SLIDE SHOW	—	—	●	—
D. EFFECT	●	—	●	OFF
PICT. EFFECT	●	—	●	OFF
FRAME REC	●	—	—	OFF



Position of lamp: **TAPE** **MEMORY** **PLAY/EDIT** **Easy Handycam**

	TAPE	MEMORY	PLAY/EDIT	Easy Handycam
SMTH INT.REC	●	—	—	—
INT.REC-STL	—	●	—	—
DEMO MODE	●	—	—	ON
PictBridge PRINT	—	—	●	—
USB SELECT	—	—	●	—

 **EDIT/PLAY menu** (p. 53)

 VAR. SPD PB	—	—	●	—
 REC CTRL	—	—	●	—
AUD DUB CTRL	—	—	●	—
 REC MOVIE	—	—	●	—
BURN DVD	—	—	●	—
END SEARCH	●	—	●	—

 **STANDARD SET menu** (p. 54)

 REC MODE	●	—	●	SP
AUDIO MODE	●	—	●	12BIT
VOLUME	—	—	●	●
MULTI-SOUND	—	—	●	STEREO
AUDIO MIX	—	—	●	—
EXT SUR MIC	●	—	—	
LCD/VF SET	●	●	●	—/NORMAL/— / NORMAL/—*2
A/V → DV OUT	—	—	●	OFF
VIDEO INPUT	—	—	●	—*2
TV TYPE	●	●	●	—*2
USB CAMERA	●	—	—	—
DISP GUIDE	●	●	●	—
GUIDEFAME	●	●	—	OFF
DATA CODE	—	—	●	●
 REMAINING	●	—	●	AUTO
REMOTE CTRL	●	●	●	ON
REC LAMP	●	●	—	ON
BEEP	●	●	●	●
DISP OUTPUT	●	●	●	LCD PANEL
MENU ROTATE	●	●	●	—
A.SHUT OFF	●	●	●	5min
CALIBRATION	—	—	●	—

 **TIME/LANGU. menu** (p. 58)

CLOCK SET	●	●	●	●
WORLD TIME	●	●	●	—*2
LANGUAGE	●	●	●	—*2

*1 Cannot be operated in the CAMERA-TAPE mode.

*2 The setting value before entering Easy Handycam operation will be retained.

CAMERA SET menu

Settings to adjust your camcorder to the recording conditions (EXPOSURE/WHITE BAL./STEADYSHOT, etc.)

The default settings are marked with ►. The indicators in parentheses appear when the items are selected.

See page 36 for details on selecting menu items.

PROGRAM AE

You can record pictures effectively in various situations with the PROGRAM AE function.

► AUTO

Select to automatically record pictures effectively without the [PROGRAM AE] function.

SPOTLIGHT*()



Select to prevent people's faces from appearing excessively white when subjects are lit by strong light.

PORTRAIT (Soft portrait) ()



Select to bring out the subject such as people or flowers while creating a soft background.

BEACH&SKI*()



Select to prevent people's faces from appearing dark in strong light or reflected light, such as at a beach in midsummer or on a ski slope.

SUNSET&MOON**()



Select to maintain the atmosphere of situations such as sunsets, general night

views or fireworks.

LANDSCAPE**()



Select to shoot distant subjects clearly. This setting also prevents your camcorder from focusing on glass or metal mesh in windows that comes in between the camcorder and the subject.

- Items with one asterisk (*) can be adjusted to focus on subjects only a short distance away. Items with two asterisks (**) can be adjusted to focus on subjects farther away.

SPOT METER (Flexible spot meter)

You can adjust and fix the exposure to the subject, so that it is recorded in suitable brightness even when there is strong contrast between the subject and the background, such as subjects in the spotlight on stage.

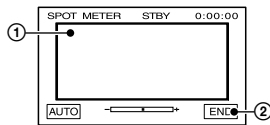

- ① Touch the point where you want to fix and adjust the exposure on the screen.

—|<=>|>— appears.

- ② Touch [END].

To return the setting to automatic exposure, touch [AUTO]→[END].

- If you set [SPOT METER], [EXPOSURE] is automatically set to [MANUAL].

EXPOSURE

You can fix the brightness of a picture manually. When recording indoors on a clear day, for instance, you can avoid backlight shadows on people next to the window by fixing the exposure to that of the wall side of the room.

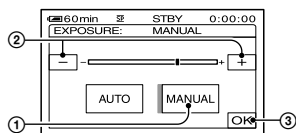

- ① Touch [MANUAL].
- ② Adjust the exposure by touching / .
- ③ Touch [OK].
 appears.

To return the setting to automatic exposure, touch [AUTO] → [OK].

- You can also adjust the setting using the CAM CTRL dial (p. 61).

WHITE BAL. (White balance)

You can adjust the color balance to the brightness of the recording environment.

► AUTO

The white balance is adjusted automatically.

OUTDOOR (☀)

The white balance is adjusted to be appropriate for the following recording conditions:

- Outdoors
- Night views, neon signs and fireworks
- Sunrise or sunset
- Under daylight fluorescent lamps

INDOOR (💡)

The white balance is adjusted to be appropriate for the following recording conditions:

- Indoors
- At party scenes or studios where the lighting conditions change quickly
- Under the video lamps of those at a studio, or under sodium lamps or incandescent-like color lamps

ONE PUSH (📷)

The white balance will be adjusted according to the ambient light.

- ① Touch [ONE PUSH].

- ② Frame a white object such as a piece of paper, to fill the screen under the same lighting conditions as you will shoot the subject.

- ③ Touch [].

flashes quickly. When the white balance has been adjusted and stored in the memory, the indicator stops flashing.

- Keep framing a white object while is flashing quickly.
- flashes slowly if white balance could not be set.
- If keeps flashing even after you have touched [OK], set [WHITE BAL.] to [AUTO].

- When you have changed the battery pack while [AUTO] is selected, or you bring your camcorder outdoors from inside the house while using fixed exposure, select [AUTO] and aim your camcorder at a nearby white object for about 10 seconds for better color balance adjustment.
- Redo the [ONE PUSH] procedure if you change the [PROGRAM AE] settings, or bring your camcorder outdoors from inside the house, or vice versa.
- To adjust the white balance under white or cool white fluorescent lamps, set [WHITE BAL.] to [AUTO], or follow the procedure when using [ONE PUSH].
- The setting returns to [AUTO] when you have the power source disconnected from your camcorder for more than 5 minutes.

SHARPNESS

You can adjust the sharpness of the image outline with / . appears when the sharpness is anything other than the default setting.



AUTO SHUTTER

Automatically activates the electronic shutter to adjust the shutter speed when recording in bright conditions if you set it to [ON] (the default setting).

AE SHIFT

When you set [AE SHIFT] to [ON], you can adjust the exposure using (dark)/ (bright). **AS** and the setting value appear when [AE SHIFT] is set to [ON].

- You cannot use [AE SHIFT] when [EXPOSURE] is set to [MANUAL].
- You can also adjust the setting manually using the CAM CTRL dial (p. 61).

CAMERA COLOR

You can adjust the color intensity with /.

Decreases color intensity ← → Increases color intensity

WB SHIFT (White Balance Shift)

When you set [WB SHIFT] to [ON], you can adjust the white balance to the desired setting using /.

WS and the setting value are displayed when [WB SHIFT] is set to [ON].

- When the white balance is set to a lower value, pictures appear bluish, and when set to a higher value, pictures appear reddish.
- You can also adjust the setting manually using the CAM CTRL dial (p. 61).

SPOT FOCUS

You can select and adjust the focal point to aim it at a subject not located in the center of the screen.

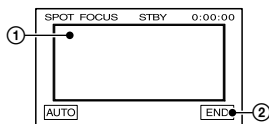

- ① Touch the subject on the screen.
 appears.

- ② Touch [END].

To adjust the focus automatically, touch [AUTO]→[END].

- If you set [SPOT FOCUS], [FOCUS] is automatically set to [MANUAL].

FOCUS

You can adjust the focus manually. Select this when you want to focus on a certain subject intentionally.



- ① Touch [MANUAL].
 appears.
- ② Touch (focusing on close subjects)/ (focusing on distant subjects) to sharpen the focus. appears when the focus cannot be adjusted any closer, and appears when the focus cannot be adjusted farther away.
- ③ Touch [OK].

To adjust the focus automatically, touch [AUTO]→[OK] in step ①.

- It is easier to focus on the subject by moving the power zoom lever towards T (telephoto) to adjust the focus, then towards W (wide angle) to adjust the zoom for recording. When you want to record a subject at close range, move the power zoom lever to W (wide angle), then adjust the focus.
- The minimum distance required between your camcorder and the subject to get a sharp focus is about 1 cm (about 1/2 in.) for wide angle and about 80 cm (about 2 5/8 feet) for telephoto.
- You can also adjust the focus manually using the CAM CTRL dial (p. 61).

EXP.FOCUS (Expanded focus)

When you set the POWER switch to CAMERA-MEMORY and [EXP.FOCUS] to [ON], you can enlarge the picture displayed on the LCD screen to 2 times bigger. This function makes it easier to adjust the focus. While displaying the enlarged picture, instead of the indicator in normal [FOCUS] setting, the indicator appears.

- When you finish focusing, the screen automatically returns to the normal picture display.

TELE MACRO

This is useful to shoot small subjects, such as flowers or insects. You can blur away backgrounds and the subject stands out clearer.

When you set [TELE MACRO] to [ON] (T), the zoom (p. 24) moves to the top of the T (Telephoto) side automatically and allows for recording subjects at a close distance, down to about 50 cm (19 3/4 in.).



To cancel, touch [OFF], or zoom to wide-angle (W side).

- When recording a distant subject, it may difficult to focus on and take time for focusing.
- Adjust the focus manually ([FOCUS], p. 42) when it is hard to focus automatically.

FLASH SET

Note that these settings will not function with external flashes (optional) that do not support the following settings.

FLASH LEVEL

HIGH(++)

Makes the flash level higher.

► NORMAL(±)

LOW(±-)

Makes the flash level lower.

- The setting returns to [NORMAL] when you disconnect the power source from your camcorder for more than 5 minutes.

REDEYE REDUC

You can prevent redden by activating the flash before recording.

Set [REDEYE REDUC] to [ON], then press **⚡** (flash) (p. 25) repeatedly to select a setting.

👁️ (Auto redden reduction): Pre-flashes to reduce redden before the flash automatically flashes when there is insufficient ambient light.



⚡ (Forced redden reduction): Always uses the flash and the redden reducing pre-flash.



🚫 (No flash): Records without flash.

- The redden reduction may not produce the desired effect due to individual differences and other conditions.

COLOR SLOW S (Color Slow Shutter)

When you set [COLOR SLOW S] to [ON], you can record an image brighter in color even in dark places.

📺 and [COLOR SLOW SHUTTER] appear on the screen.

To cancel [COLOR SLOW S], touch [OFF].

- Adjust the focus manually ([FOCUS], p. 42) when it is hard to focus automatically.
- The shutter speed of your camcorder changes depending on the brightness. The motion of the picture may slow down at this time.

ZEBRA

This is useful as a guide when adjusting the brightness. When you change the default setting, 📺 is displayed. The zebra pattern is not recorded.

► OFF

The zebra pattern is not displayed.

70

The zebra pattern appears at a screen brightness level of about 70 IRE.

100

The zebra pattern appears at a screen brightness level of about 100 IRE or higher.

- Portions of the screen where brightness is about 100 IRE or above may appear overexposed.
- The zebra pattern is diagonal stripes that appear in portions of the screen where brightness is at a preset level.

HISTOGRAM

When you set [HISTOGRAM] to [ON], the [HISTOGRAM] (a graph to display a distribution of tones in your picture) window appears on the screen. This item is useful when you adjust exposure. You can adjust the [EXPOSURE] or [AE SHIFT] checking the [HISTOGRAM] window. The [HISTOGRAM] will not be recorded on a tape or "Memory Stick Duo."

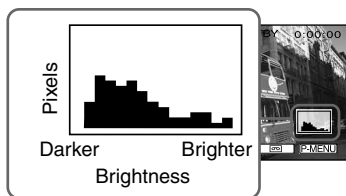

- The left area on the graph shows the darker areas of the picture while the right area shows the brighter areas.

SELF-TIMER

The self-timer starts recording after about 10 seconds.

- ① Touch **[P-MENU]** → **[SELF-TIMER]** → **[ON]** → **[OK]**.
 ⌚ appears.
- ② Press **REC START/STOP** to record movies, or **PHOTO** to record still images.
 To cancel the count down, touch **[RESET]**.

To cancel the self-timer, select **[OFF]** in step ①.

- You can also use the self-timer with the Remote Commander (p. 32).

DIGITAL ZOOM

You can select the maximum zoom level in case you want to zoom to a level greater than 10 × (the default setting) while recording on a tape. Note that the image quality decreases when you are using the digital zoom.

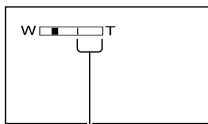

The right side of the bar shows the digital zooming factor. The zooming zone appears when you select the zooming level.

▶ OFF

Up to 10 × zoom is performed optically.

20 ×

Up to 10 × zoom is performed optically, and after that, up to 20 × zoom is performed digitally.

120 ×

Up to 10 × zoom is performed optically, and after that, up to 120 × zoom is performed digitally.

STEADYSHOT

You can compensate for camera shake (the default setting is [ON]). Set [STEADYSHOT] to [OFF] (🚫) when using a tripod (optional) or the conversion lens (optional).

PROGRES.REC

You can reduce image blur when recording moving pictures on tapes, intended for import to your computer as still images, by setting [PROGRES.REC] to [ON] (30p). This is especially useful for analyzing high-speed action, such as sports scenes. Touch [OFF] to cancel this mode.

Note on the progressive recording mode

In a normal TV broadcast, the screen is divided into 2 finer fields and these are displayed in turn, every 1/60 of a second. Thus, the actual picture displayed in an instant covers only half of the apparent picture area. In progressive recording, the picture is fully displayed with all the pixels. A picture recorded in this mode appears clearer, but a moving subject may appear awkward.

DIAL SET

You can assign the setting item to the CAM CTRL dial and adjust the assigned item manually using the CAM CTRL dial.

► [FOCUS]

Assigns [FOCUS] (p. 42) setting to the CAM CTRL dial.

[EXPOSURE]

Assigns [EXPOSURE] (p. 40) setting to the CAM CTRL dial.

[AE SHIFT]

Assigns [AE SHIFT] (p. 42) setting to the CAM CTRL dial.

[WB SHIFT]

Assigns [WB SHIFT] (p. 42) setting to the CAM CTRL dial.

- See page 61 for details on the CAM CTRL dial.

MEMORY SET menu**Settings for the “Memory Stick Duo” (BURST/QUALITY/IMAGE SIZE/ALL ERASE/NEW FOLDER, etc.)**

The default settings are marked with ►. The indicators in parentheses appear when the items are selected.

See page 36 for details on selecting menu items.

STILL SET**■  BURST**

You can record several still images one after another by pressing PHOTO.

► OFF

Select this when not recording continuously.

NORMAL 

Records from 3 (1920 × 1440 image size), 5 (1600 × 1200 image size) to 25 (640 × 480 image size) images continuously at about 0.5 second intervals.

The maximum number of images are recorded when you press and hold PHOTO fully.

EXP. BRKTG (BRK)

Records 3 images consecutively with different exposures at about 0.5 second intervals. You can compare the 3 images and select an image recorded at the best exposure.

- The flash will not function during [BURST].
- The maximum number of images will be recorded in the self-timer mode or when you are operating with the Remote Commander.
- [EXP. BRKTG] will not function when you have space for fewer than 3 images remaining on the “Memory Stick Duo.”
- When you set WIDE (16:9) ratio of the screen you can record 3 images (1920 × 1080 image size) continuously.

■  QUALITY**► FINE (FINE)**

Records still images at the fine image quality level.

STANDARD (STD)

Records still images at the standard image quality level.

IMAGE SIZE

▶ 1920 × 1440 (L₁₉₂₀)

Records still images clearly.

1600 × 1200 (L₁₆₀₀)

Allows you to record more still images in relatively clear quality.

640 × 480 (L₆₄₀)

Allows for the maximum number of images to be recorded.

- If you set 16:9 (wide) ratio of the screen, [IMAGE SIZE] is set to [1920 × 1080] automatically (p. 19).

Capacity of the “Memory Stick Duo” (MB) and the number of recordable pictures

In 4:3 aspect ratio

	1920 × 1440 * L ₁₉₂₀	1600 × 1200 * L ₁₆₀₀	640 × 480* L ₆₄₀
16MB (supplied)	11 26	16 37	96 240
32MB	22 54	32 75	190 485
64MB	45 105	65 150	390 980
128MB	91 215	130 300	780 1970
256MB	165 395	235 540	1400 3550
512MB	335 800	480 1100	2850 7200
1GB	680 1600	980 2250	5900 14500

- * Top: [FINE] is selected for image quality.
Bottom: [STANDARD] is selected for image quality.

In 16:9 aspect ratio

	1920 × 1080 * L ₁₉₂₀	640 × 360 * L ₆₄₀
16MB (supplied)	14 34	115 240
32MB	29 69	240 485
64MB	59 135	490 980
128MB	115 280	980 1970
256MB	215 500	1750 3550
512MB	435 1000	3600 7200
1GB	890 2100	7300 14500

- * Top: [FINE] is selected for image quality.
Bottom: [STANDARD] is selected for image quality.

- When using the “Memory Stick Duo” made by Sony Corporation. The number of recordable pictures varies depending on the recording environment.
- The image size of a 4:3 picture is as follows.
 - [FINE] is selected for an image size of [1920 × 1440] - approx. 1380kB.
 - [FINE] is selected for an image size of [1600 × 1200] - approx. 960kB.
 - [FINE] is selected for an image size of [640 × 480] - approx. 150kB.
 - [STANDARD] is selected for an image size of [1920 × 1440] - approx. 580kB.
 - [STANDARD] is selected for an image size of [1600 × 1200] - approx. 420kB.
 - [STANDARD] is selected for an image size of [640 × 480] - approx. 60kB.
- The image size of a 16:9 picture is as follows.
 - [FINE] is selected for an image size of [1920 × 1080] - approx. 1060kB.
 - [FINE] is selected for an image size of [640 × 360] - approx. 130kB.
 - [STANDARD] is selected for an image size of [1920 × 1080] - approx. 450kB.
 - [STANDARD] is selected for an image size of [640 × 360] - approx. 60kB.

MOVIE SET

IMAGE SIZE

▶ 320 × 240 (320)

Records movies in high resolution.

160 × 112 (160)

Allows for more movie recording time.

Capacity of the “Memory Stick Duo” (MB) and the recordable time (hour: minute: second)

	320 × 240 320	160 × 112 160
16MB (supplied)	00:02:40	00:10:40
32MB	00:05:20	00:21:20
64MB	00:10:40	00:42:40
128MB	00:21:20	01:25:20
256MB	00:42:40	02:50:40
512MB	01:25:20	05:41:20
1GB	02:50:40	11:22:40

- When using the “Memory Stick Duo” made by Sony Corporation. The recordable time varies depending on the recording environment.

ALL ERASE

Deletes all the pictures on a “Memory Stick Duo” without image protection, or in the selected folder.

- ① Select [ALL FILES] or [CURRENT FOLDER].
[ALL FILES]: Deletes all the images on the “Memory Stick Duo.”
[CURRENT FOLDER]: Deletes all the images in the selected folder.
 - ② Touch [YES] twice → [X].
- Cancel image protection on the “Memory Stick Duo” beforehand when using the “Memory Stick Duo” with the write-protect tab (p. 108).
 - The folder will not be deleted even when you delete all the pictures in the folder.

- Do not do any of the following while [Erasing all data...] is displayed:
 - Operate the POWER switch/operation buttons.
 - Eject the “Memory Stick Duo.”

FORMAT

The supplied or newly purchased “Memory Stick Duo” has been formatted at the factory, and does not require formatting.

To execute formatting, touch [YES] twice → [X].

Formatting is completed, and all the images will be deleted.

- Do not do any of the following while [Formatting...] is displayed:
 - Operate the POWER switch/operation buttons.
 - Eject the “Memory Stick Duo.”
- Formatting erases everything on the “Memory Stick Duo” including protected image data and newly created folders.

FILE NO.

▶ SERIES

Assigns file numbers in sequence even if the “Memory Stick Duo” is replaced with another one. The file number is reset when a new folder is created or the recording folder is replaced with another.

RESET

Resets the file number to 0001 each time the “Memory Stick Duo” is changed.

NEW FOLDER

You can create a new folder (102MSDCF to 999MSDCF) on a “Memory Stick Duo.” When a folder is full (a maximum of 9999 images are stored) a new folder is automatically created.

Touch [YES] → [X].

- You cannot delete the created folders using your camcorder. You will have to format the “Memory Stick Duo” (p. 47), or delete them using your computer.
- The number of recordable pictures on a “Memory Stick Duo” may decrease as the number of folders increases.

REC FOLDER (Recording folder)

Select the folder to be used for recording with [▲]/[▼], then touch [OK].

- As the default setting, pictures are saved in the 101MSDCF folder.
- Once you record a picture in a folder, the same folder will be set as the default folder for playback.

PB FOLDER (Playback folder)

Select the playback folder with [▲]/[▼], then touch [OK].

PICT.APPLI. menu

Special effects on pictures or additional functions on recording/playback (SLIDE SHOW/PICT. EFFECT/FRAME REC, etc.)

The default settings are marked with ►. The indicators in parentheses appear when the items are selected.

See page 36 for details on selecting menu items.

FADER

You can add the following effects to currently recording pictures.

- ① Select the desired effect, then touch [OK].
When you select [OVERLAP], [WIPE] or [DOT FADER], the image on a tape is stored as a still image. (While storing the image, the screen turns to blue.)
- ② Press REC START/STOP.
The fader indicator stops flashing and disappears when the fade is complete.

To cancel the operation, touch [OFF] in step ①.



WHITE FADER



BLACK FADER



MOSAIC FADER



MONOTONE

When fading in, the picture gradually changes from black-and-white to color. When fading out, it gradually changes from color to black-and-white.

OVERLAP (fade in only)**WIPE (fade in only)****DOT FADER (fade in only)****SLIDE SHOW**

Plays back the images stored on a “Memory Stick Duo,” or in a folder in sequence (slide show).

- ① Touch [SET] → [PB FOLDER].
- ② Select [ALL FILES (all)] or [CURRENT FOLDER (T)], then touch [OK].
If you select [CURRENT FOLDER (T)], all the images in the current playback folder selected in [PB FOLDER] (p. 48) are played back in sequence.
- ③ Touch [REPEAT].
- ④ Select [ON] or [OFF], then [OK].
To repeat the slide show, select [ON] (C).
To execute the slide show only once, select [OFF].
- ⑤ Touch [END] → [START].

To cancel [SLIDE SHOW], touch [END].
To pause, touch [PAUSE].

- You can select the first picture for the slide show with [−]/[+] before touching [START].
- If movies are played in the slide show, you can adjust the volume with [Q−]/[Q+].

D. EFFECT (Digital effect)

You can add digital effects to your recordings.

- ① Touch the desired effect.
- ② Adjust the effect with [−]/[+], then touch [OK].

When you select [STILL] or [LUMI. KEY], the image when you touch [OK] is saved as a still image.

Effect	Items to adjust
CINEMA EFFECT*	No adjustment necessary.
DELAY MOTION	The speed of repeats
STILL	The degree of transparency of the still image you want to superimpose on a movie.
FLASH	The interval of frame-by-frame playback.
LUMI. KEY	The color scheme of the area in the still image which is to be swapped with a movie.
TRAIL	The fade time of the incidental image.
SLOW SHUTTR*	Shutter speed (1 is 1/30, 2 is 1/15, 3 is 1/8, 4 is 1/4).
OLD MOVIE*	No adjustment necessary.

* Available during recording only.

- ③ Touch [OK].
[D+] appears.

To cancel [D. EFFECT], touch [OFF] in step ①.

CINEMA EFFECT (Cinematic effect)

You can add a cinematic atmosphere to pictures by adjusting to a 16:9 screen and progressive picture.

DELAY MOTION (Delay motion)

You can record a movie with a repeat effect.

STILL

Records a movie while superimposing it on a previously recorded still image.



FLASH (flash motion)

Records a movie with a serial-still-image effect (strobe effect).

LUMI. KEY (luminance key)

Replaces a brighter area in a previously recorded still image (e.g. background of a person) with a movie.



TRAIL

Records a picture so that an incidental image like a trail is left.

SLOW SHUTTR (slow shutter)



The shutter speed is slowed down. Suitable for shooting a subject more clearly in a dark place.

- Adjust the focus manually using a tripod since adjusting the focus automatically is hard when [SLOW SHUTTR] is selected. ([FOCUS], p. 42)

OLD MOVIE

Adds an old movie effect with a sepia hue to pictures.

- You cannot change to another digital effect while recording pictures on a tape with [CINEMA EFFECT] selected.
- The digital effect function is suspended while using zoom with [DELAY MOTION] selected.
- It is recommended that you mount your camcorder on a tripod when you select [DELAY MOTION].
- You cannot select 16:9/4:3 as the aspect ratio for [OLD MOVIE].
- You cannot record pictures edited using special effects on the tape in your camcorder.

- You cannot add effects to externally input pictures. The playback pictures edited with digital effects are output via the  DV Interface (i.LINK or  (USB) jack without effect control.
- You can save pictures edited using special effects on a "Memory Stick Duo" (p. 66) or record them on another tape (p. 64).

PICT. EFFECT (Picture effect)

You can add special effects to a picture during recording or playback.  appears.

▶ OFF

Does not use [PICT. EFFECT] setting.

SKINTONE

Makes skin texture look more smoother and more appealing.

NEG.ART



The color and brightness are reversed.

SEPIA

Pictures appear in sepia.

B&W

Pictures appear in black and white.

SOLARIZE



Pictures appear as an illustration with strong contrast.

PASTEL



Pictures appear as a pale pastel drawing.*

MOSAIC



Pictures appear mosaic-patterned.*

* Available during recording only.

- While using the back light function, you cannot select [SKINTONE]. And when you use the back light function with [PICT.EFFECT] set to [SKINTONE], the [SKINTONE] setting will be cancelled.
- You cannot add effects to externally input pictures. The playback pictures edited with picture effects are output via the DV Interface (i.LINK) or (USB) jack without effect control.
- You can save pictures edited using special effects on a “Memory Stick Duo” (p. 66) or record them on another tape (p. 64).

FRAME REC (Frame recording)

You can record pictures with a stop-motion animated effect by alternately frame recording and then moving the subject a little. Operate your camcorder using the Remote Commander to prevent camera shake.

- ① Touch [ON] () → [OK] → [X].
 - ② Press REC START/STOP.
A picture (approximately 6 frames) is recorded, and your camcorder enters the standby mode.
 - ③ Move the subject and repeat step ②.
- The remaining tape time will not be indicated correctly.
 - The last scene will be longer than other scenes.

SMTH INT.REC (Smooth interval tape recording)

Your camcorder will shoot 1 frame of the picture at a selected interval and keep them in memory until it has stored several frames. This function is useful to observe the movement of clouds or the changes of daylight. These pictures appear smooth when played back. Connect your camcorder to the wall outlet using the supplied AC Adaptor for this operation.

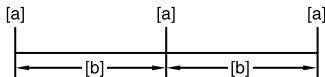

[a]: Recording

[b]: Interval

- ① Touch [SET] → [−]/[+] to select a desired interval time (1 to 120 seconds) → [OK].
- ② Touch [REC START].
Recording starts and  changes to red.

To interrupt, touch [REC STOP] in step ②.
To resume, touch [REC START].
To cancel, touch [REC STOP], then [END].

- When your camcorder has shot several frames, it records them on the tape, after performing the END SEARCH function depending on the interval length.
- Do not turn off the power or disconnect the power source while a message is displayed on the screen.
- The camcorder will shoot several frames for the first and last shots of the Smooth interval recording.
- Smooth interval recording is released when approximately 12 hours have elapsed after shooting has begun.
- Sounds are not recorded.
- The last few frames may not be recorded if the battery or tape has run out.
- There may be discrepancies in the interval.
- If you adjust the focus manually, you can record clear pictures even if the light changes ([FOCUS], p. 42).
- You can silence the recording beep by setting of [BEEP] (p.57).

INT.REC-STL (Interval photo recording)

You can record still images on the “Memory Stick Duo” at a selected interval. This function is useful to observe the movement of clouds or the changes in daylight, etc.

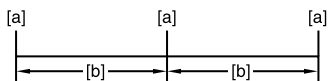

[a]: Recording

[b]: Interval

① Touch [SET] → a desired interval time (1, 5 or 10 minutes) → [OK] → [ON] → [OK] → [X].

② Press PHOTO fully.

 stops flashing and the interval still image recording starts.

To cancel [INT.REC-STL], select [OFF] in step ①.

DEMO MODE

The default setting is [ON], allowing you to view the demonstration in about 10 minutes, after you have removed both a cassette and a “Memory Stick Duo” from your camcorder, and slide the POWER switch down to turn on the CAMERA-TAPE lamp.

- The demonstration will be suspended in situations such as those described below.
 - When you touch the screen during the demonstration. (The demonstration starts again in about 10 minutes.)
 - When a cassette or a “Memory Stick Duo” is inserted.
 - When the POWER switch is set to other than CAMERA-TAPE.

PictBridge PRINT

See page 70.

USB SELECT

You can connect the camcorder to a personal computer with a USB cable (supplied) and view pictures on the computer. You can also connect the camcorder to a PictBridge-compatible printer (p. 70) using this function. Refer to “First Step Guide” on the supplied CD-ROM for details.

[MEMORY STICK]

Select this to view pictures on a “Memory Stick Duo” on the computer or to import them to the computer.

[PictBridge PRINT]

Select this when you connect the camcorder to a PictBridge-compatible printer to print out directly (p. 70).

[DV STREAM]

Select this to view movies on a tape on the computer or to import them to the computer.

[MULTI CONNCT]

Select this to view pictures on a “Memory Stick Duo” or a tape on the computer. You can also select this mode to import pictures to the computer. This mode is convenient since you need not change the mode for either media.

- [MULTI CONNCT] or [DV STREAM] is available only for Windows XP Service Pack 1 (SP1) or Windows XP Service Pack 2 (SP2) supporting High-Speed USB (USB 2.0) device.

EDIT/PLAY menu

Settings for editing or playing back in various modes (VAR.SPD PB/END SEARCH, etc.)







The default settings are marked with ►.
The indicators in parentheses appear when the items are selected.

See page 36 for details on selecting menu items.

VAR.SPD PB (Various speed playback)

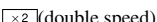
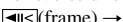
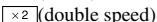
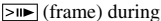

You can play back in various modes while viewing movies.

- ① Touch the following buttons during playback.

To	Touch
change the playback direction*	 (frame)
play back slowly**	 To reverse direction :  (frame) → 
play back 2 times faster (double speed)	 (double speed) To reverse direction:  (frame) →  (double speed)
play back frame by frame	 (frame) during playback pause. To reverse direction:  (frame) during frame playback.

* Horizontal lines may appear at the top, bottom, or in the center of the screen. This is not a malfunction.

** Pictures output from the  DV Interface (i.LINK) cannot be played back smoothly in slow mode.

- ② Touch  → .

To return to the normal playback mode, touch  (Play/Pause) twice (once from frame playback).

- You will not hear the recorded sound. You may see mosaic-like images of the previously played picture.

REC CTRL (Movie recording control)

See page 65.

AUD DUB CTRL (Audio dubbing)

See page 68.

REC MOVIE (Recording control)

See page 66.

BURN DVD

When your camcorder is connected to a Sony VAIO series personal computer, you can easily burn the picture recorded on the tape on a DVD (Direct Access to “Click to DVD”) using this command. See “Creating a DVD (Direct Access to “Click to DVD”)” (p. 81) for details.

END SEARCH

EXEC

The most recently recorded picture is played back for about 5 seconds and then stops automatically.

CANCEL

Stops [END SEARCH].

STANDARD SET menu

Settings while recording on a tape or other basic settings (REC MODE/MULTI-SOUND/LCD/VF SET/DISP OUTPUT, etc.)

The default settings are marked with ►. The indicators in parentheses appear when the items are selected.

See page 36 for details on selecting menu items.

REC MODE (Recording mode)

► SP (SP)

Records in the SP (Standard Play) mode on a cassette.

LP (LP)

Increases the recording time to 1.5 times the SP mode (Long Play).

- If you record in the LP mode, a mosaic-like noise may appear or sound may be interrupted when you play back the tape on other camcorders or VCRs.
- When you mix recordings in the SP mode and in the LP mode on one tape, the playback picture may be distorted or the time code may not be written properly between the scenes.

AUDIO MODE



► 12BIT

Records in the 12-bit mode (2 stereo sounds).

16BIT (16b)

Records in the 16-bit mode (1 stereo sound with high quality).

VOLUME

Touch  /  to adjust the volume.

- You can also adjust the setting manually using the CAM CTRL dial (p. 23).

MULTI-SOUND

You can select whether to play back audio recorded using other devices with dual sound or stereo sound.

► STEREO

Plays back with main and sub sound (or stereo sound).

1

Plays back with main sound or the left channel sound.

2

Plays back with sub sound or the right channel sound.

- You can play back, but cannot record a dual sound track cassette on your camcorder.
- The setting returns to [STEREO] when you have the power source disconnected from your camcorder for more than 5 minutes.

AUDIO MIX



You can monitor the sound recorded on the tape with audio dubbing or 4CH MIC recording during playback.

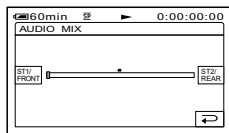

When playing back an audio dubbed recording

See page 68.

When playing back a 4CH MIC recording



Touch  /  to adjust the balance of the front and rear sound. Then touch .

You can monitor the front sound at the  side, and the rear sound at the  side. Your camcorder cannot output 4ch audio simultaneously as it only supports 2ch audio output. When you set the audio balance bar to the center, the front and rear sounds are output at equal level. The adjusted audio balance returns to the default setting in about 5 minutes after the battery pack, or other power source has been disconnected.

EXT SUR MIC (External surround microphone)

You can enjoy 5.1ch surround sound by following the procedure below, using an optional microphone and a Sony VAIO series personal computer.

Recording

Attach the ECM-HQP1 microphone (optional) to your camcorder and make a recording.

Record four audio channels (front-left, front-right, rear-left, and rear-right) simultaneously.



Creating DVD

Create a DVD compliant with 5.1ch surround sound playback on a Sony VAIO series personal computer using "Click to DVD" (Ver.2.0 or later).



Playback

Play back the created DVD on the 5.1ch home theater system.

- ① Connect the ECM-HQP1 microphone (optional) to the Active Interface Shoe. Refer to the manual of the microphone for details.
- ② Select the sound setting.

▶ 4CH MIC (🔊 4ch-12b)

Records 4 channel sound, front L/R and rear L/R, at the same time by connecting a microphone (optional).

WIDE STEREO (🔊)

Records 2 channel sound with more presence by connecting a microphone (optional).

STEREO

Records the stereo sound normally.

- This manual describes how to record. For details on creating a DVD ("Click to DVD" function), see page 81 or refer to "First Step Guide" on the supplied CD-ROM (p. 80).
- You need a compatible accessory such as the ECM-HQP1 microphone (optional) to record the sound in the [4CH MIC] or [WIDE STEREO] setting.



- Sound is recorded in the [STEREO] setting if the microphone is not connected, even if another setting is selected.
- Sound is recorded in the 12-bit mode in [4CH MIC]. If [AUDIO MODE] has been set to [16BIT (16b)], it automatically switches to the 12-bit mode. The audio mode setting returns to the previous settings if you change the setting from [4CH MIC] to [WIDE STEREO] or [STEREO].
- You can check the recorded front and rear sound after recording ([AUDIO MIX], p.54).
- Your camcorder cannot output 5.1ch surround sound.
- For creating a 5.1ch surround sound compliant DVD, you need software and a device that supports this function. In the case of Sony products, a VAIO series personal computer pre-installed with "Click to DVD" (Ver.2.0 or later) supports this function.
- Some application software bundled with VAIO does not allow for 4CH MIC recording signal.

LCD/VF SET

The recorded picture will not be affected by this operation.

■ LCD BRIGHT

You can adjust the brightness of the LCD screen.

- ① Adjust the brightness with  / .
- ② Touch .

■ LCD BL LEVEL

You can adjust the brightness of the LCD screen's backlight.

▶ NORMAL

Standard brightness.

BRIGHT

Brightens the LCD screen.

- When you connect your camcorder to outside power sources, [BRIGHT] is automatically selected for the setting.
- When you select [BRIGHT], battery life is slightly reduced during recording.

LCD COLOR

You can adjust the color on the LCD screen with /.



VF B. LIGHT

You can adjust the brightness of the viewfinder.

► NORMAL

Standard brightness.

BRIGHT

Brightens the viewfinder screen.

- When you connect your camcorder to outside power sources, [BRIGHT] is automatically selected for the setting.
- When you select [BRIGHT], battery life is slightly reduced during recording.

VF WIDE DISP

You can select how a 16:9 aspect ratio picture appears in the viewfinder.

► LETTER BOX

Normal setting (standard type of display)

SQUEEZE (Squeeze)

Expands the picture vertically when black bands appear at the top and bottom of the screen in 16:9 aspect ratio.

A/V→DV OUT

When you set [A/V→DV OUT] () to [ON], you can convert the signal to the appropriate one by connecting a digital device and an analog device to your camcorder. See page 84 for details.

VIDEO INPUT

Selects the video plug to connect when you input the picture from the other device via A/V connecting cable.

► VIDEO

Connects via video plug of the A/V connecting cable (supplied).

S VIDEO

Connects via S VIDEO plug of the A/V connecting cable with S VIDEO cable (optional).

TV TYPE

See page 34.

USB CAMERA

When you set [USB CAMERA] to [DV STREAM] and connect your camcorder to your computer via the USB cable (supplied), you can view the picture your camcorder is currently seeing on your computer like a live camera.

You can also import the picture to your computer. Refer to the "First Step Guide" on the supplied CD-ROM for details.

- [USB CAMERA] is available only for Windows XP Service Pack1 (SP1) or Windows XP Service Pack2 (SP2) supporting High-Speed USB (USB 2.0) device.

DISP GUIDE

See page 15.

GUIDEFAME

You can display the frame and check that the subject is horizontal or vertical by setting [GUIDEFAME] to [ON]. The frame is not recorded. Press DISPLAY BATT INFO to make the frame disappear.

- Pointing the subject at the cross point of the guide frame makes a balanced composition.

DATA CODE

Displays information recorded automatically (data code) during recording.

► OFF

Data code is not displayed.

DATE/TIME

Displays the date and time.

CAMERA DATA (below)

Displays camera setting data.

This cannot be selected during Easy Handycam operation.

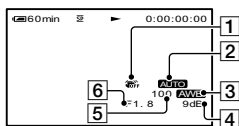

- 1 SteadyShot off*
- 2 Exposure*
- 3 White balance*
- 4 Gain*
- 5 Shutter speed
- 6 Aperture value

* Appears only during tape playback.

- Camera setting data does not appear when movies on a "Memory Stick Duo" are played back.
- The exposure adjustment value (0EV), a shutter speed, and the aperture value appear when still images on a "Memory Stick Duo" are played back.
- appears for a picture recorded using a flash.
- In the DATE/TIME data display, the date and time are displayed in the same area. If you record a picture without setting the clock, [--- -- ----] and [--:--:--] will appear.

REMAINING**▶ AUTO**

Displays the remaining tape indicator for about 8 seconds in situations such as those described below.

- When you set the POWER switch to PLAY/EDIT or CAMERA-TAPE with a cassette inserted.
- When you touch (Play/Pause).

ON

Always displays the remaining tape indicator.

REMOTE CTRL (Remote control)

The default setting is [ON], allowing you to use the Remote Commander (p. 32).

- Set to [OFF] to prevent your camcorder from responding to a command sent by another VCR remote control unit.
- The setting returns to [ON] when you have the power source disconnected from your camcorder for more than 5 minutes.

REC LAMP (Recording lamp)

The camera recording lamp will not light up during recording when you set this to [OFF]. (The default setting is [ON].)

BEEP**▶ ON**

A melody sounds when you start/stop recording, or operate the touch panel.

OFF

Cancels the melody.

DISP OUTPUT**▶ LCD PANEL**

Shows displays such as the time code on the LCD screen and in the viewfinder.

V-OUT/PANEL

Shows displays such as the time code on the TV screen, LCD screen, and in the viewfinder.

(CLOCK SET/WORLD TIME/LANGUAGE)**MENU ROTATE****► NORMAL**

Scrolls the menu items downwards by touching .

OPPOSITE

Scrolls the menu items upwards by touching .

A.SHUT OFF (Auto shut off)**► 5 min**

The camcorder is automatically turned off when you do not operate your camcorder for more than approximately 5 minutes.

NEVER

The camcorder is not automatically turned off.

- When you connect your camcorder to a wall outlet, [A.SHUT OFF] is automatically set to [NEVER].



CALIBRATION

See page 114.

CLOCK SET

See page 16.

WORLD TIME

When using your camcorder abroad, you can set the time difference by touching /, the clock will be adjusted in accordance with the time difference.

If you set the time difference to 0, the clock returns to the originally set time.

LANGUAGE

You can select the language to be used on the LCD screen.

You can select from English, Simplified English, Canadian-French, Latin American Spanish, Brazilian-Portuguese, or Korean.

- Traditional Chinese is also available on menu for customers who bought this product in Asia, Middle East, Canada, Latin America or in Japan (as an Overseas Model).
- Your camcorder offers [ENG[SIMP]] (simplified English) for when you cannot find your native tongue among the options.

Customizing Personal Menu

You can add desired menu items to Personal Menu, and customize Personal Menu settings for each POWER switch position. This is convenient if you add frequently used menu items to Personal Menu.

Adding a menu item

You can add up to 28 menu items for each POWER switch position. Delete a less important menu item, if you want to add more.

- 1 Touch [P-MENU] → [P-MENU SET UP] → [ADD].

If the desired menu item is not displayed, touch \uparrow/\downarrow .

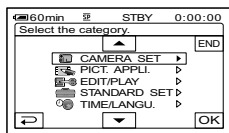

- 2 Touch \uparrow/\downarrow to select a menu category, then touch [OK].

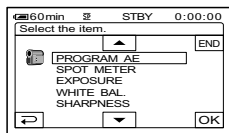

- 3 Touch \uparrow/\downarrow to select a menu item, then touch [OK] → [YES] → [X].

The menu item is added to the end of list.

Deleting a menu item

- 1 Touch [P-MENU] → [P-MENU SET UP] → [DELETE].

If the desired menu item is not displayed, touch \uparrow/\downarrow .

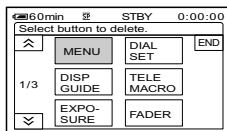

- 2 Touch the menu item that you want to delete.

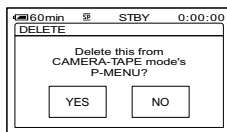

- 3 Touch [YES] → [X].

- You cannot delete [MENU] and [P-MENU SET UP].

Arranging the order of menu items displayed on Personal Menu

- 1 Touch **[P-MENU]** → **[P-MENU SET UP]** → **[SORT]**.

If the desired menu item is not displayed, touch **[↕]**/**[↕]**.

- 2 Touch the menu item you want to move.

- 3 Touch **[▲]**/**[▼]** to move the menu item to the desired place.

- 4 Touch **[OK]**.

To sort more items, repeat steps 2 to 4.

- 5 Touch **[END]** → **[X]**.

- You cannot move [P-MENU SET UP].

Initializing the Personal Menu settings (Reset)

- Touch **[P-MENU]** → **[P-MENU SET UP]** → **[RESET]** → **[YES]** → **[YES]** → **[X]**.

If the desired menu item is not displayed, touch **[↕]**/**[↕]**.

Using the CAM CTRL dial

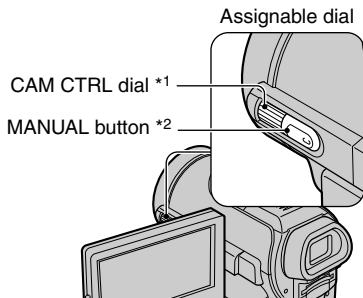

*1 You can adjust the assigned item manually.

*2 Press this button to switch the assigned item auto/manual setting.

You can assign some of your setting items to the CAM CTRL dial and adjust the following settings with the dial operation. The settings that can be set with the dial operation are the same with those on the menu.

[FOCUS] is assigned to the CAM CTRL dial at the time of purchase.

Items that can be set

- [FOCUS] (p. 42)
 - [EXPOSURE] (p. 40)
 - [AE SHIFT] (p. 42)
 - [WB SHIFT] (P. 42)
- You can easily change settings only with the CAM CTRL dial and the MANUAL button while recording.
 - During playback (when the POWER switch is set to PLAY/EDIT), you can adjust the volume with the CAM CTRL dial (p. 23).

Setting with the CAM CTRL dial

The following is an example of the procedure to adjust [FOCUS] setting manually. The procedure is the same for other setting items.

1 Set the POWER switch to CAMERA-TAPE or CAMERA-MEMORY.

2 Press the MANUAL button.

The indicator of the setting item appears on the screen.



- See page 30 for the name and display position of the indicators.

3 Rotate the CAM CTRL dial and adjust the setting.

Adjust the focus manually in case of the [FOCUS] setting.

Press the MANUAL button again when you want to return to the auto setting.

Changing the item assigned to the CAM CTRL dial

Select the setting item from the [DIAL SET] menu to change the item assigned to the CAM CTRL dial (p. 45). You can assign the item with the following procedure as well.

1 Set the POWER switch to CAMERA-TAPE or CAMERA-MEMORY.

2 Press and hold the MANUAL button for several seconds.

The [DIAL SET] screen appears.

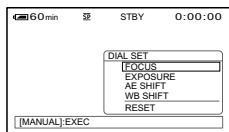

3 Rotate the CAM CTRL dial and select an item to be assigned.

4 Press the MANUAL button.

A message appears and you can set the selected item with the dial operation.



- Manual settings will be retained even if you change an assigned item.
If [AE SHIFT] and [EXPOSURE] are set at the same time, [EXPOSURE] overrides [AE SHIFT].
- If you select [RESET] in Step 3, all the settings set manually return to the default setting. The item assigned to the CAM CTRL dial returns to [FOCUS].

Connecting to a VCR or TV

Connect your camcorder to a VCR or a TV to one of the following connections. Connect your camcorder to the wall outlet using the supplied AC Adaptor for this operation (p. 9). Refer also to the instruction manuals supplied with the devices to be connected.

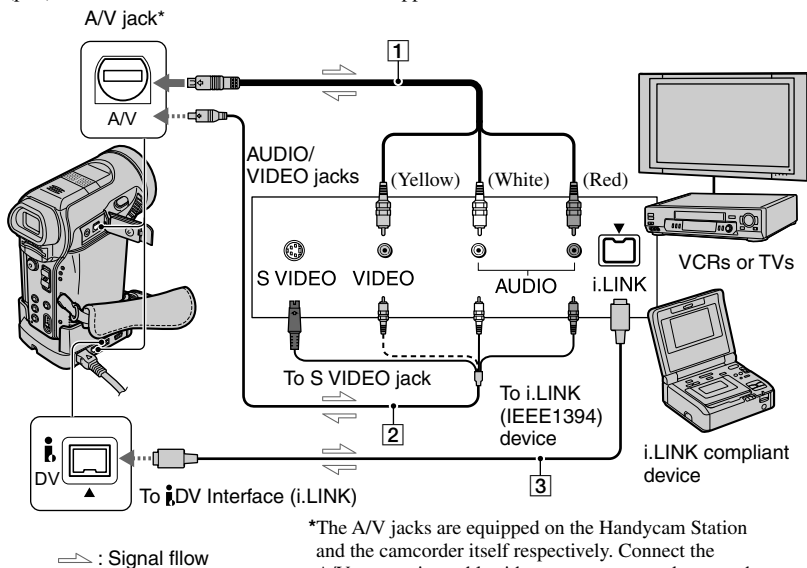

*The A/V jacks are equipped on the Handycam Station and the camcorder itself respectively. Connect the A/V connecting cable either to your camcorder or to the Handycam Station.

1 A/V connecting cable (supplied)

Connect the A/V connecting cable to your camcorder or the Handycam Station. The A/V jack works as an input as well as an output, switching automatically depending on the operational status.

2 A/V connecting cable with S VIDEO (optional)







When connecting to another device via the S VIDEO jack, by using the A/V connecting cable with an S VIDEO cable (optional), pictures can be reproduced more faithfully than with the supplied A/V cable connection. Connect the white and red plugs (left/right audio) and S VIDEO plug (S VIDEO channel) of an A/V connecting cable (optional). In this case, the yellow (standard video) plug connection is not necessary. S VIDEO connection only will not output audio.

3 i.LINK cable (optional)

Use an i.LINK cable (optional) to connect your camcorder to another device. The video and audio signals are transmitted digitally, producing high quality pictures. Note that you cannot output the picture and sound separately.

- Connect the A/V connecting cable to the output jack of a device you are dubbing a picture from, or to the input jack of another device for dubbing a picture from your camcorder.
- When you are connecting your camcorder to a monaural device, connect the yellow plug of the A/V connecting cable to the video jack, and the red (right channel) or the white (left channel) plug to the audio jack on the VCR or the TV.
- When you connect a device via an A/V connecting cable (supplied), set [DISP OUTPUT] to [LCD PANEL] (the default setting) (p. 57) to prevent the screen display dubbed with pictures.

Connecting to a VCR or TV (Continued)

- You cannot use [DV STREAM] via the  DV Interface (i.LINK) and via the  (USB) jack at the same time. When using the  DV Interface (i.LINK), disconnect the USB cable (supplied) from the  (USB) jack.
- While your camcorder is receiving signals from another device via an i.LINK cable (optional), **DV IN ** appears on the LCD screen, and while your camcorder is sending signals to another device via an i.LINK cable (optional), **DVout ** appears on the LCD screen on your camcorder.

Dubbing to another device such as a VCR, DVD recorder, etc.

You can copy the picture played back on your camcorder to other recording devices (such as VCRs).

1 Connect your VCR to your camcorder as a recording device.

See page 63 for connection details.

2 Prepare your VCR for recording.

When dubbing to the VCR, insert a cassette for recording.

When dubbing to the DVD recorder, insert a DVD for recording.

If your recording device has an input selector, set it to set it to the appropriate input (such as video input1, video input2, etc.).

3 Prepare your camcorder for playback.

Insert the recorded cassette.

Set [TV TYPE] according to the playback device (TV, etc.) (p. 34).

4 Start the playback on your camcorder, and record it on the VCR.

Refer to the operating instructions supplied with your recording device for details.

5 When the dubbing is finished, stop your camcorder and the VCR.

- The following cannot be output via the iDV interface (i.LINK):
 - Indicators
 - [PICT. EFFECT] (p. 50), [D. EFFECT] (p. 49) or PB zoom (p. 26).
 - Titles that are recorded on other camcorder.
- To record the date/time and camera settings data when connected by the A/V connecting cable (supplied), display them on the screen (p. 56).
- When connected using an i.LINK cable (optional), the recorded picture becomes rough when a picture is paused on your camcorder while recording to a VCR.
- When connected using an i.LINK cable (optional), data code (date/time/camera settings data) may not be displayed or recorded depending on the device or application.

Recording pictures from a VCR or TV

You can record pictures or TV programs from a VCR or TV on a tape or a “Memory Stick Duo.” You can also record a scene as a still image on a “Memory Stick Duo.” Be sure to insert a cassette or a “Memory Stick Duo” for recording in your camcorder beforehand.

- You cannot record pictures when the output jacks are not equipped on your TV.

Recording movies

1 Connect your TV or VCR to your camcorder.

See page 63 for details of connecting.

- The DV IN indicator appears when you connect your camcorder and other devices via an i.LINK cable. (This indicator may also appear on your TV.)
- When using the A/V connecting cable, connect your camcorder to the output jacks on your TV or VCR.

2 If you are recording from a VCR, insert a cassette.

3 Slide the POWER switch down to turn on the PLAY/EDIT lamp.

4 Operate your camcorder to record movies.

When recording on a tape, touch **[P-MENU]** → **[REC CTRL]** → **[REC PAUSE]**.

When recording on a “Memory Stick Duo,” touch **[P-MENU]** → **[MENU]** → **[EDIT/PLAY]** → **[REC MOVIE]**.

Recording pictures from a VCR or TV (Continued)

5 Start playing the cassette on your VCR, or select a TV program.

The picture played on the connected device appears on the LCD screen of your camcorder.

6 Touch [REC START] at the point you want to start recording.

7 Stop recording.

When recording on a tape, touch  (STOP) or [REC PAUSE].

When recording on a “Memory Stick Duo,” touch [REC STOP].

8 Touch → .

Recording still images

1 Perform steps 1 to 3 in “Recording movies.”

2 Play the video, or receive the TV program you want to record.

The pictures on the VCR or TV appear on the screen of your camcorder.

3 Press PHOTO lightly at the scene you want to record. Check the image and press it fully.



Dubbing pictures from a tape to a “Memory Stick Duo”

You can record movies or still images on a “Memory Stick Duo.” Make sure you have a recorded tape and a “Memory Stick Duo” inserted into your camcorder.





1 Slide the POWER switch down to turn on the PLAY/EDIT lamp.



2 Search and record the scene you want to record.

When you dub pictures as a still image

Touch   (PLAY) to play back the tape, then press PHOTO lightly at the scene you want to record. Check the image and press it fully.

When you dub pictures as a movie

Touch [P-MENU] → [MENU] →  (EDIT/PLAY) →  [REC MOVIE] →   (PLAY) to play back the tape, then touch [REC START] at the point you want to start recording.

At the point you want to stop recording, touch [REC STOP] →  (STOP) →  → .

- You cannot dub pictures to a “Memory Stick Duo” while playing back with [DELAY MOTION] selected in [D. EFFECT].
- The data code recorded on the tape cannot be recorded on the “Memory Stick Duo.” The time and date the picture is recorded on the “Memory Stick Duo” will be recorded.
- The sound is recorded in 32kHz monaural.
- For the recording time of movies, see page 47.
- Still images will be fixed to image size [640 × 360] when playing back the 16:9 picture, or [640 × 480] when playing back the 4:3 picture.

Dubbing sound to a recorded tape

You can add sound to a tape already recorded in the 12-bit mode (p. 54) without erasing the original sound.

Connecting

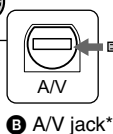
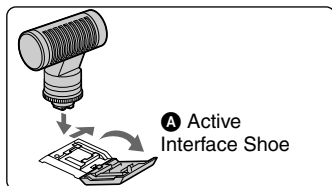

*The A/V jacks are equipped on the Handycam Station and the camcorder itself respectively. Connect the A/V connecting cable either to your camcorder or to the Handycam Station.

A/V connecting cable (supplied)

Do not connect the Video plug (Yellow).

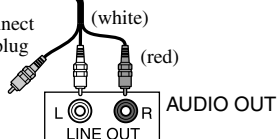

Audio device (such as CD/MD) players

: Signal flow

You can record audio by connecting in one of the following ways.

- A** An external microphone (optional) to the Active Interface Shoe.
- B** An audio device to the Handycam Station or your camcorder using the A/V connecting cable.
- C** Using the internal microphone (no connection required).

The audio input to be recorded takes precedence over others in the order of

A → **B** → **C**.

You cannot record additional audio:

– When the tape has been recorded in the 16-bit mode (p. 54).

- When the tape has been recorded in the LP mode.
- When your camcorder is connected via an i.LINK cable (optional).
- When the tape is recorded in 4CH MIC mode.
- On blank sections of the tape.
- When the tape has been recorded in a TV color system other than that of your camcorder.
- When the write-protect tab of the cassette is set to SAVE.
- When you are using the A/V jack or the internal microphone, the picture will not be output from the A/V jack. Check the picture on the LCD screen or the viewfinder.

Dubbing sound to a recorded tape (Continued)

- When you attach an external microphone (optional) to the Active Interface Shoe, you can check the picture and the sound by connecting your camcorder to a TV or other device using the A/V connecting cable. However, sound you are recording is not output from your camcorder. Check the sound using a TV or other device.

Recording sound

Insert a recorded cassette into your camcorder beforehand.

1 Slide the **POWER** switch down to turn on the **PLAY/EDIT** lamp.

2 Touch **▶||** (Play/Pause) to play back the tape, then touch it again at the point where you want to start recording the sound.

3 Touch **P.MENU** → **[MENU]** →  (EDIT/PLAY) → **[AUD DUB CTRL]** → **[OK]** → **[AUDIO DUB]**.

 appears

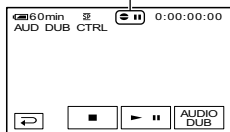

4 Touch **▶||** (play) and start playing back the audio you want to record at the same time.

 appears while recording the new sound in stereo 2 (ST2) during the playback of the tape.

5 Touch  (stop) when you want to stop recording.

To dub on other scenes, repeat step 2 to select scenes, then touch **[AUDIO DUB]**.



6 Touch  → **[X]**.

- To set the end point for audio dubbing, beforehand, press ZERO SET MEMORY on the Remote Commander at the scene at which you want to stop audio dubbing during playback. After step 2 to 4, the recording stops automatically at the selected scene.
- You can only record additional audio over a tape recorded on your camcorder. The sound may deteriorate when you dub audio on a tape recorded on other camcorders (including other DCR-PC1000 camcorders).

To check the recorded sound

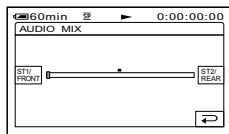
- ① Play back the tape on which you have recorded audio (p. 23).
- ② Touch **P.MENU** → **[MENU]** →  (STANDARD SET) → **[OK]** → **[AUDIO MIX]** → **[OK]**.



- ③ Touch  /  to adjust the balance of the original sound (ST1) and the sound recorded afterwards (ST2), then touch **[OK]**.
- The original sound (ST1) is output at the default setting.
 - The adjusted audio balance returns to the default setting in about 5 minutes after the battery pack or other power sources have been disconnected.

Deleting recorded pictures from the “Memory Stick Duo”

1 Slide the **POWER** switch down to turn on the **PLAY/EDIT** lamp.

2 Touch **MEMORY**.

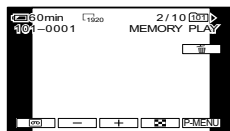

3 Select a picture you want to delete with **[-]/[+]**.

- To delete all pictures at once, select **[F1]** **ALL ERASE** (p. 47).

4 Touch **[F1]** → **[YES]**.

- The pictures cannot be restored once they are deleted.
- You can delete pictures on the index screen (p. 23). You can easily search for the picture to be deleted by displaying 6 pictures at once. Touch **[SET]** → **[DELETE]** → the picture you want to delete → **[OK]** → **[YES]**.
- Pictures cannot be deleted when a “Memory Stick Duo” with the write-protect tab is set to the write-protect position (p. 108), or when the selected picture is protected (p. 69).

Marking images on the “Memory Stick Duo” with specific information (Image protection/Print mark)

When you are using a “Memory Stick Duo” with the write-protect tab, make sure the write-protect tab on the “Memory Stick Duo” is not set to the write-protect position (p. 108).

Preventing accidental erasure (Image protection)

You can select and mark images to prevent accidental erasure.

1 Slide the **POWER** switch down to turn on the **PLAY/EDIT** lamp.

2 Touch **MEMORY** → **[F2]** → **[SET]** → **[PROTECT]**.

3 Touch the image that you want to protect.

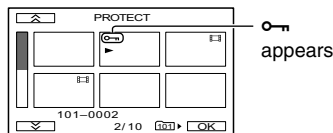

4 Touch **[OK]** → **[END]**.

- To cancel image protection, touch the image again to cancel image protection in step 3.

Marking images on the “Memory Stick Duo” with specific information (Image protection/Print mark) (Continued)

Selecting still images for printing (Print mark)

The DPOF (Digital Print Order Format) standard is used to select images for printing on your camcorder.

By marking images that you want to print out, you do not need to reselect them when you print them out. (You cannot specify the number of printouts.)

1 Slide the **POWER** switch down to turn on the **PLAY/EDIT** lamp.

2 Touch **MEMORY** →  → **SET** → **[PRINT MARK]**.

3 Touch the image that you want to print out later.

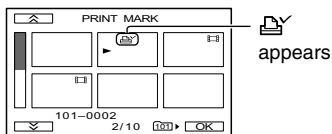

4 Touch **OK** → **[END]**.

- To cancel Print mark, touch the image again to cancel Print mark in step **3**.
- Do not mark images on your camcorder if the “Memory Stick Duo” already has some images with the Print mark put on using other devices. This may change the information of the images with the Print mark put on using the other device.

Printing recorded images (PictBridge compliant printer)

You can print out pictures using a PictBridge compliant printer without connecting the camcorder to a computer.



PictBridge

Connect the AC Adaptor to the Handycam Station to supply power from the wall outlet.

Insert the “Memory Stick Duo” on which still images are stored into your camcorder and insert your camcorder to the Handycam Station. Then turn on the power of the printer.

Connect your camcorder to the printer

1 Slide the **POWER** switch down to turn on the **PLAY/EDIT** lamp.

2 Touch **P-MENU** → **[MENU]** →  **(PICT.APPLI.)** → **[USB SELECT]** → **[PictBridge PRINT]** → **OK** → .

- You can also touch **P-MENU** → **[MENU]** →  **(PICT.APPLI.)** → **[PictBridge PRINT]** instead of the above.

3 Connect the  (**USB**) jack of the Handycam Station to the printer using the **USB cable (supplied)**.

4 Set the **USB ON/OFF** switch of the Handycam Station to **[ON]**.

When [“PictBridge PRINT”] connecting] appears on the screen, touch **OK**.

When connection is complete, **4** (PictBridge connecting) appears on the screen.

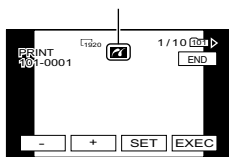

One of the images stored on the “Memory Stick Duo” will be displayed.

- We cannot guarantee the operation of models that are not PictBridge compatible.

Printing

1 Select the image to be printed with **[-]/[+]**.

2 Touch **[SET]**→**[COPIES]**.

3 Select the number of copies to be printed with **[-]/[+]**.

You can set a maximum of 20 copies of one image to be printed.

4 Touch **[OK]**→**[END]**.

To print the date on the image, touch **[SET]**→**[DATE/TIME]**→**[DATE]** or **[DAY&TIME]**→**[OK]**.

5 Touch **[EXEC]**→**[YES]**.

When printing is finished, **[Printing...]** disappears and the image selection screen appears again.

Touch **[END]** when printing is completed.

- Refer also to the operating instructions for the printer to be used.
- Do not attempt the following operations when **4** is on the screen. The operations may not be performed properly.
 - Operating the POWER switch.
 - Remove your camcorder from the Handycam Station.
 - Set the USB ON/OFF switch to **[OFF]**.
 - Disconnect the USB cable (supplied) from the Handycam Station or the printer.
 - Removing the “Memory Stick Duo” from your camcorder.
- If the printer stops working, disconnect the USB cable (supplied), turn the printer off and on again and restart the operation from the beginning.
- If you print a still image recorded with a 16:9 ratio, left and right ends of the image may be cut off.
- Some printer models may not support the date printing function. Refer to your printer’s operating instructions for details.
- We cannot guarantee the printing of images recorded with a device other than your camcorder.
- PictBridge is an industry standard established by the Camera & Imaging Products Association (CIPA). You can print still images without using a computer by connecting a printer directly to a digital video camera or digital still camera, regardless of model or manufacturer.

Jacks to connect external devices

Camcorder

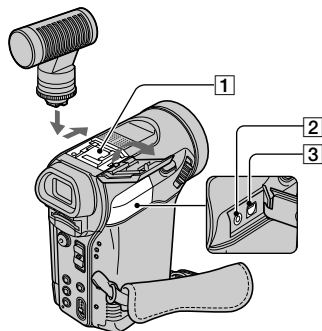

- The Active Interface Shoe has a safety device for fixing the installed accessory securely. To connect an accessory, press down and push it to the end, and then tighten the screw. To remove an accessory, loosen the screw, and then press down and pull out the accessory.
- When you are recording on a “Memory Stick Duo” with an external flash (optional) connected to the accessory shoe, turn off the power of the external flash to prevent charging noise being recorded.
- You cannot use an external flash (optional) and the built-in flash at the same time.
- When an external microphone (optional) is connected, it takes precedence over the internal microphone (p. 27).

Handycam Station

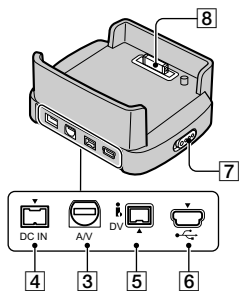

2 LANC jack (blue)

- The LANC control jack is used for controlling the tape transport of video devices and peripherals connected to it.

3 A/V (audio/video) jack (p. 34, 63, 84)

4 DC IN jack (p. 9)

5 DV Interface (i.LINK) jack (p. 63, 81)

6 USB jack

- When you set the POWER switch to PLAY/EDIT and connect the USB cable (supplied), the window to check the previous connection setting appears. When you use the connection setting displayed on the screen, touch [OK]. If you touch [SETTING], you can change the connection setting on the [USB SELECT] (p. 52) screen.
- When you change the connection setting on the [USB SELECT] screen, the window to check the connection setting won't appear.

7 USB ON/OFF switch

- Set the USB ON/OFF switch to [ON] while using the USB connection.

8 Interface connector

1 Active Interface Shoe (p. 67)

The Active Interface Shoe supplies power to optional accessories such as a video light, a flash, or a microphone. The accessory can be turned on or off as you operate the POWER switch on your camcorder. Refer to the operating instructions supplied with your accessory for details.

- When you connect an accessory, open the shoe cover. Pull up the shoe cover, then rotate it to the direction of the arrow to open.

Before referring to the “First Step Guide” on your computer

When you install the Picture Package Ver.1.7 software on a Windows computer from the supplied CD-ROM, you can enjoy the following operations by connecting your camcorder to your computer.

- Software and features available for Macintosh computers differ from those available for Windows computers. For details, refer to chapter 6 of “First Step Guide” on CD-ROM. For “First Step Guide”, see the next section.
- There are 2 ways to connect your camcorder to a computer.
 - USB cable (supplied)
 - i.LINK cable (optional)

For details on connection, see “First Step Guide”.

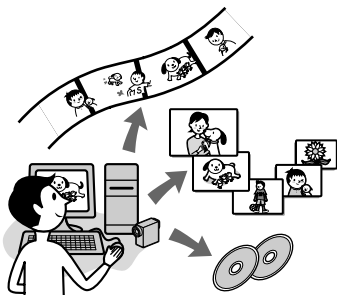

Viewing video and pictures on PC

You can view the video and still images copied from your camcorder by selecting from thumbnails. Video and still images are saved in folders by date.

Music Video/Slideshow Producer

You can select your favorite video and still images from video and still images saved on your computer and easily create an original short video or original slide show with added music and visual styles.

Automatic Music Video Producer

You can easily create an original short video with added music and visual styles using video recorded on a tape.

Copying tape to Video CD

You can import the entire contents of a tape to create a video CD.

Save the images on CD-R

You can save video and still images copied onto a computer to a CD-R.

Burning Video CD

You can compose a video CD with a menu of videos and slide shows. ImageMixer VCD2 is compatible with high resolution still images.

- The CD-ROM (supplied) includes the following software.
 - USB Driver
 - Picture Package Ver.1.7
 - ImageMixer VCD2
 - “First Step Guide”

About “First Step Guide”

“First Step Guide” is an instruction manual you can refer to on your computer. This “First Step Guide” describes basic operations, from initial hookup of your camcorder and computer and making settings, to general operation the first time you use the software and “First Step Guide” stored on the CD-ROM (supplied). After installing the CD-ROM, reading “Viewing “First Step Guide”” (p. 80), start the “First Step Guide”, then follow the instructions.

About the help function of the software

The Help guide explains all the functions of all the software applications. Refer to the Help guide for further detailed operations after reading the “First Step Guide” thoroughly. To display the Help guide, click the [?] mark on the screen.

System requirements

■ For Windows users

When using Picture Package

OS: Microsoft Windows 98, Windows 98SE, Windows 2000 Professional, Windows Millennium Edition, Windows XP Home Edition or Windows XP Professional Standard installation is required. Operation is not assured if the above OS has been upgraded. DV STREAM in USB connection is only compatible with Windows XP Service Pack1 (SP1) and Service Pack2 (SP2). DV capturing via the i.LINK interface is not compatible with Windows 98 and Windows 98 SE.

CPU: Intel Pentium III 500 MHz or faster (800 MHz or faster recommended) (For using ImageMixer VCD2, Intel Pentium 4 1.3 GHz or faster recommended)

Application: DirectX 9.0c or later (This product is based on DirectX technology. It is necessary to have DirectX installed.)
Windows Media Player 7.0 or later
Macromedia Flash Player 6.0 or later

Sound system: 16 bit stereo sound card and stereo speakers

Memory: 128 MB or more

Hard disk: Available memory required for installation: 500 MB or more
Available free hard disk space recommended: 6 GB or more (depending on the size of the image files edited)

Display: 4 MB VRAM video card, Minimum 800 × 600 dots, High color (16 bit color, 65 000 colors), DirectDraw display driver capability (This product will not operate correctly at less than 800 × 600 dots, or less than 256 colors.)

Others: ⚡ (USB) port (This must be provided as standard. DV STREAM requires Hi-Speed USB (USB 2.0.), an i.LINK interface (IEEE1394, i.LINK) (to connect via an i.LINK cable), disc drive (You need a CD-R drive to create a video CD.
For the compatible drive, visit the following
URL: <http://www.ppackage.com/>)

When playing pictures recorded on a “Memory Stick Duo” on a computer

OS: Microsoft Windows 98, Windows 98SE, Windows 2000 Professional, Windows Millennium Edition, Windows XP Home Edition or Windows XP Professional Standard installation is required. Operation is not assured if the above OS has been upgraded.

CPU: MMX Pentium 200MHz or faster

Application: Windows Media Player (This must be installed to play back movies.)

Others: ⚡ (USB) port (This must be provided as standard), disc drive

■ For Macintosh users

When using ImageMixer VCD2

OS: Mac OS X (v10.1.5 or later)

CPU: iMac, eMac, iBook, PowerBook, PowerMac G3/G4/G5 series

Memory: 128 MB or more

Hard disk: Available memory required for installation: 250 MB or more
Available free hard disk space recommended: 4 GB or more (depending on the size of the image files edited)

Display: Minimum 1 024 × 768 dots, 32 000 colors (This product will not operate correctly at less than 1 024 × 768 dots or 256 colors.)

Application: QuickTime 4 or later
(QuickTime 5 recommended)

Other: Disc drive

When only copying pictures recorded on a “Memory Stick Duo” on a computer

OS: Mac OS 9.1/9.2 or Mac OS X (v 10.0/v 10.1/v 10.2/v 10.3)

Application: QuickTime 3.0 or later (This must be installed to play back movies.)

Others: ⏏ (USB) port (This must be provided as standard)

- When you connect your camcorder to a Macintosh computer using a USB cable (supplied), you cannot copy pictures recorded on a tape to the computer. To copy recordings from a tape, connect your camcorder to the computer with an i.LINK cable (optional) and use the standard software in the OS.

Installing the software and “First Step Guide” on a computer

You need to install the software etc., with the supplied CD-ROM on your computer **before connecting your camcorder** and your computer. Once you install it, the installation is not required thereafter.

The software to be used varies depending on the OS system you are using.

Windows computer: Picture Package (including ImageMixer VCD2)

Macintosh computer: ImageMixer VCD2
For the details on the software, refer to “First Step Guide”.

Installing on a Windows computer

Log on as Administrators for installation for Windows 2000/Windows XP.

1 Confirm that your camcorder is not connected to the computer.

2 Turn on the computer.

Close all applications running on the computer before installing the software.

3 Place the CD-ROM in the disc drive of your computer.

The installation screen appears.



If the screen does not appear

- 1 Double-click [My Computer].
- 2 Double-click [PICTUREPACKAGE] (Disc drive).*

* Drive names (such as (E:)) may vary depending on the computer.

4 Click [Install].



Depending on the operating system on the computer, a message appears notifying you that “First Step Guide” cannot be installed automatically with the InstallShield Wizard. In such a case, manually copy “First Step Guide” to your computer according to the message’s instructions.

5 Select the language for the application to be installed, then click [Next].



6 Click [Next].

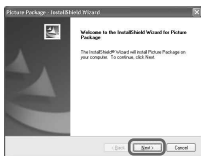

7 Read [License Agreement], check [I accept the terms of the license agreement] when you agree, then click [Next].



8 Select where to save the software, then click [Next].



9 Click [Install] on the [Ready to Install the Program] screen.

The installation of Picture Package starts.



10 Click [Next] to install the “First Step Guide.”

Depending on the computer, this screen may not be displayed. In such a case, skip to step 11.



Follow the on-screen instructions until installation of “First Step Guide” is complete.

11 Click [Next], then follow the on-screen instructions until installation of ImageMixer VCD2 is complete.



12 If the [Installing Microsoft (R) DirectX(R)] screen is displayed, follow the steps below to install DirectX 9.0c. If not, skip to step 13.

- 1 Read [License Agreement], then click [Next].



- 2 Click [Next].



- 3 Click [Finish].



13 Follow the steps below to install USB driver for using DV STREAM.

Only displayed with Windows XP Service Pack 1 (SP1). Otherwise skip to step 14.

- 1 Click [Next].



- 2 Read [License Agreement], check [I Agree] when you agree, then click [Next].



- ③ Click [Finish].



14 Make sure [Yes, I want to restart my computer now.] is checked, then click [Finish].



The computer turns off once, then starts up again automatically (Restart). The short-cut icons for [Picture Package Menu] and [Picture Package Menu destination Folder] (and “First Step Guide”, if installed by steps 10) appear on the desktop.



15 Follow the steps below to update DirectX 9. Only displayed with Windows XP Service Pack1 (SP1).

- ① Click [Next].



- ② Read [License Agreement], check [I Agree] when you agree, then click [Next].



- ③ Click [Finish].



16 Remove the CD-ROM from the disc drive of your computer.

- If you have any questions about Picture Package, contact information is listed on page 80.

Installing on a Macintosh computer

- 1** Confirm that your camcorder is not connected to the computer.
- 2** Turn on the computer.

Close all applications running on the computer before installing the software.
- 3** Place the CD-ROM in the disc drive of your computer.
- 4** Double-click CD-ROM icon.
- 5** Copy “FirstStepGuide.pdf,” stored in the desired language in the [FirstStepGuide] folder, to your computer.
- 6** Copy [IMXINST.SIT] in the [MAC] folder of the CD-ROM to a folder of your choice.
- 7** Double-click [IMXINST.SIT] in the folder it was copied to.
- 8** Double-click the unzipped [ImageMixerVCD2_Install].
- 9** When the user acceptance screen is displayed, enter your name and password.

The installation of ImageMixer VCD2 starts.

- For details on how to use ImageMixer VCD2, refer to software’s on-line help.

Viewing “First Step Guide”

Displaying “First Step Guide”

Starting up on a Windows computer

Viewing with Microsoft Internet Explorer Ver.6.0 or later is recommended.

Double-click the  icon on the desktop.

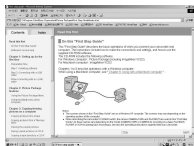

You can also start by selecting [Start], [Programs] ([All Programs] for Windows XP), [Picture Package], and [First Step Guide], then start up [First Step Guide].

- To view “First Step Guide” in HTML without using automatic installation, copy the desired language folder from the [FirstStepGuide] folder on the CD-ROM, and then double-click “index.html”.
- Refer to “FirstStepGuide.pdf” located in your desired language in the following cases:
 - When printing “First Step Guide”
 - When “First Step Guide” is not displayed correctly due to the browser setting even in recommended environment.
 - When the HTML version of “First Step Guide” is not installed automatically.

Starting up on a Macintosh computer

Double-click “FirstStepGuide.pdf”.



To view the PDF, Adobe Reader is needed. If it is not installed on your computer, you can download it from the Adobe Systems web page:
<http://www.adobe.com/>

For inquires about this software

Pixela User Support Center

Pixela Home Page

Windows: <http://www.ppackage.com/>

Macintosh: <http://www.ImageMixer.com/>

– North America (Los Angeles) Telephone:

+1-213-341-0163

– Europe (U.K.) Telephone:

+44-1489-564-764

– Asia (Philippines) Telephone:

+63-2-438-0090

On Copyrights

Music works, sound recording or other third party musical contents you may acquire from CDs, the Internet or other sources (the “Music Contents”) are the copyrighted work of the respective owners thereof and are protected by copyright laws and other applicable laws of each country/region. Except to the extent expressly permitted by applicable laws, you are not permitted to use (including, without limitation, copying, modifying, reproducing, uploading, transmitting or placing to the external network accessible to the public, transferring, distributing, lending, licensing, selling and publishing) any of the Music Contents without obtaining authorization or approval of the respective owners thereof. License of Picture Package by Sony Corporation would not be construed as conferring to you by implication, estoppel or otherwise, any license or right to use the Music Contents.

Creating a DVD (Direct Access to “Click to DVD”)

You can create DVDs when you connect your camcorder to a Sony VAIO series computer* that supports “Click to DVD” via an i.LINK cable (optional). The picture is automatically copied and written to a DVD.

The following procedures describe how to create a DVD from a picture recorded on a tape. For system and operation requirements, visit the following URL:

- Europe
<http://www.vaio-link.com/>
- USA
<http://cisddb.sel.sony.com/perl/select-p-n.pl>
- Asia Pacific Regional
<http://www.css.ap.sony.com/>
- Korea
<http://scs.sony.co.kr/>
- Taiwan
<http://vaio-online.sony.com/tw/vaio/>
- China
<http://www.sonystyle.com.cn/vaio/>
- Thailand
<http://www.sony.co.th/vaio/index.html>
- Latin America
<http://vaio-online.sony.com/>

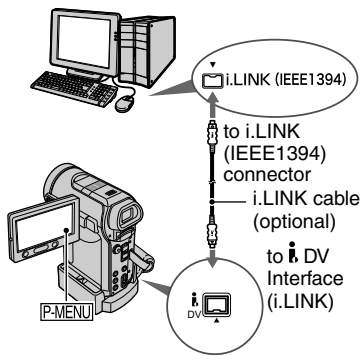

- You can only use an i.LINK cable (optional) for this operation. You cannot use a USB cable (supplied).

* Note that you need a Sony VAIO computer equipped with a DVD drive that can be used to write DVDs. You also need the computer with “Click to DVD Ver.1.2” (Sony original software) or later installed.

Using the Direct Access to “Click to DVD” function for the first time

The Direct Access to “Click to DVD” function enables you to copy pictures recorded on a tape to a DVD easily if your camcorder is connected to a computer. Before operating the Direct Access to “Click to DVD” function, follow the steps below to start “Click to DVD Automatic Mode Launcher.”

- ① Turn on the computer.
- ② Click the start menu, then select [All Programs].
- ③ Select [Click to DVD] from the programs displayed, then click [Click to DVD Automatic Mode Launcher].
[Click to DVD Automatic Mode Launcher] starts up.

- After you start up [Click to DVD Automatic Mode Launcher] once, from then on it starts up automatically when you turn on your computer.
- [Click to DVD Automatic Mode Launcher] is set up for each Windows XP user.

1 Turn on the computer.

Close all applications running with an i.LINK.

2 Prepare the power source for the camcorder.

Use the supplied AC Adaptor as the power source since it takes a few hours to create a DVD.

3 Slide the **POWER** switch down to turn on the **PLAY/EDIT** lamp.

4 Insert a recorded cassette into your camcorder.

5 Connect the Handycam Station to a computer via an i.LINK cable (optional) (p. 81).

- When you connect your camcorder to a computer, make sure you insert the connector in the correct direction. If you insert the connector forcibly, it may be damaged, and causes a malfunction of your camcorder.
- For details, see “First Step Guide”.

6 Touch **P-MENU** → **[MENU]** →  **(EDIT/PLAY)** → **[BURN DVD]** → **[OK]**.

“Click to DVD” starts up and the on-screen instructions appear on your computer.

7 Place a writable DVD in the disc drive of the computer.

8 Touch **[EXEC]** on the screen of your camcorder.

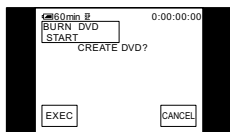

The status of the operation on your computer is displayed on the LCD screen of your camcorder.

CAPTURING: The picture recorded on the tape is being copied to the computer.

CONVERTING: The picture is being converted to the MPEG2 format.

WRITING: The picture is being written onto the DVD.

- If you use a DVD-RW/+RW which has other data stored on it, the message [This is a recorded disc. Delete and overwrite?] appears on the LCD screen of your camcorder. When you touch [EXEC], the existing data is erased and new data is written.

9 Touch **[NO]** to finish creating a DVD.

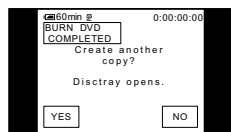

The disc tray comes out automatically. To create another DVD with the same content, touch [YES].

The disc tray comes out. Place a new writable DVD in the disc drive. Then, repeat step 8 and 9.

To cancel the operation

Touch **[CANCEL]** on the LCD screen on your camcorder.

- You cannot cancel the operation after [Finalizing DVD.] is displayed on the LCD screen of your camcorder.
- Do not disconnect the i.LINK cable (optional) or set the **POWER** switch to another mode on your camcorder until the picture is completely copied to the computer.
- When **[CONVERTING]** or **[WRITING]** is displayed on the screen, capturing of pictures has already finished. Even if you disconnect the i.LINK cable or turn off the camcorder at this stage, DVD creation will continue on your computer.

- When any of the following occurs, copying of the picture is canceled. A DVD containing the data up to the point the operation was canceled is created. Refer to the help files of “Click to DVD Automatic Mode Launcher” for details.
 - When there is a blank portion of 10 seconds or longer on the tape.
 - When the data of the tape contains a date before the recording date of the later images.
 - When normal and wide size pictures are recorded on the same tape.
- You cannot operate your camcorder in the following situations:
 - While playing back a tape
 - While recording images onto a “Memory Stick Duo”
 - When “Click to DVD” is started up from the computer
 - When [A/V→DV OUT] in the menu setting of your camcorder is set to [ON].

Connecting an analog VCR to the computer via your camcorder (Signal convert function)

Using the A/V connecting cable and an i.LINK cable (optional) or a USB cable (supplied), you can convert an analog signal output from an analog device such as a VCR to a digital signal and transfer it to a digital device, such as a computer, via your camcorder. Software that can record the video signal must be installed on your computer beforehand.

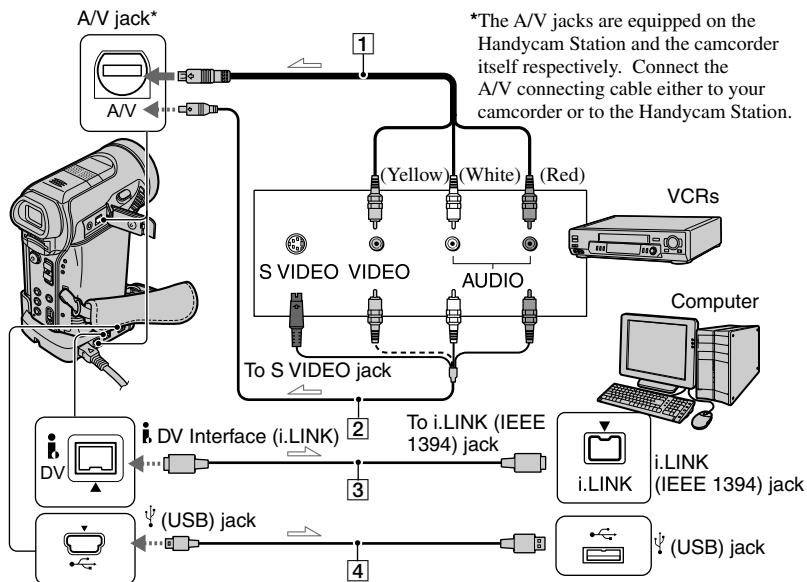

1 A/V connecting cable (supplied)

Connect the A/V connecting cable to your camcorder or the Handycam Station. The A/V jack accepts analog signals.

2 A/V connecting cable with S VIDEO (optional)

When connecting to another device via the S VIDEO jack, by using the A/V connecting cable with an S VIDEO cable (optional), pictures can be reproduced more faithfully than with the supplied A/V cable connection. Connect the white and red plugs (left/right audio) and S VIDEO plug (S VIDEO channel) of an A/V connecting cable (optional). In this case, the yellow (standard video) plug connection is not necessary. S VIDEO connection only will not output audio.

3 i.LINK cable (optional)

Use an i.LINK cable (optional) to connect your camcorder to another device. The video and audio signals are transmitted digitally, producing high quality pictures. Note that you cannot output the picture and sound separately.

4 USB cable (supplied)

You can connect your camcorder and your computer with a USB cable (supplied).

- You can use a USB cable (supplied) only for Windows XP Service Pack1 (SP1) or Windows XP Service Pack2 (SP2) supporting High-Speed USB (USB 2.0) device.
- You cannot convert an analog signal to digital via the DV Interface (i.LINK) and via the USB jack at the same time. Be sure not to connect an i.LINK cable (optional) and a USB cable (supplied) at the same time.

- While your camcorder is sending signals to other device, **A/V/DV i.LINK** appears on the LCD screen when using the i.LINK cable (optional). While sending such signals when using the USB cable (supplied), **A/V/DV USB** also appears.

Set [DISP OUTPUT] to [LCD PANEL] on the menu (p. 57) beforehand. (The default setting is [LCD PANEL].) Connect the camcorder and the video device using the A/V connecting cable or the A/V connecting cable with the S VIDEO cable attached beforehand.

- When connecting the camcorder and the computer using a USB cable (supplied)
Be sure not to connect a USB cable (supplied) at this time.
- When connecting the camcorder and the computer using an i.LINK cable (optional)
Connect an i.LINK cable beforehand.

1 Turn on the analog video unit.

2 Slide the POWER switch of your camcorder down to turn on the PLAY/EDIT lamp.

Use the supplied AC Adaptor as the power source.

3 On the LCD screen, touch **P-MENU**

→ [MENU] →  (STANDARD SET) → [A/V→DV OUT] → [ON] → [OK].

When using a USB cable (supplied)

Touch **P-MENU** → [MENU] →  (PICT. APPL.) → [USB SELECT] → [DV STREAM], then connect the camcorder to the computer using a USB cable (supplied).

4 Start playback on the analog video unit.

5 Start capturing procedures on your computer.

Regarding operation, refer to the operating instructions supplied with the software or the on-line help.

After capturing images and sound, stop capturing procedures on your computer, and stop playback on the analog video unit.

-
- Video Capturing Tool in the bundled software Picture Package supports the signal convert function. When you use this function, remove a cassette tape from your camcorder.
 - The bundled software ImageMixer VCD2 does not support the signal convert function.
 - You may not be able to output the pictures correctly depending on the condition of the analog video signal input to your camcorder.
 - You cannot transfer pictures with copyright protection signals to a computer.
 - When you are using a USB cable (supplied) or an i.LINK cable (optional) to connect your camcorder to a computer, make sure you insert the connectors in the correct direction. If you insert the connectors forcibly, they may be damaged, and cause a malfunction of your camcorder.

Troubleshooting

If you run into any problems using your camcorder, use the following table to troubleshoot the problem. If the problem persists, remove the power source and contact your Sony dealer.

Overall operations/Easy Handycam

The power does not turn on.

- The battery pack is discharged, running low, or not attached to the camcorder.
- Attach a charged battery pack to the camcorder (p. 9).
- Use the AC Adaptor to connect to a wall outlet (p. 9).
- Insert your camcorder into the Handycam Station correctly (p. 10).

The camcorder does not operate even when the power is set to on.

- Disconnect the AC Adaptor from the wall outlet or remove the battery pack, then reconnect it after about 1 minute. If the functions still do not work, press the RESET button (p. 26) using a sharp-pointed object. (If you press the RESET button, all settings, including the clock setting, are reset, except the Personal Menu items.)

Buttons do not work.

- During Easy Handycam operation, the available buttons are limited (p. 21).

You cannot turn Easy Handycam operation on or off.

- During recording or communicating with another device via USB cable (supplied), you cannot turn Easy Handycam operation on or off.

Settings change during Easy Handycam operation.

- During Easy Handycam operation, the settings of the functions that are not displayed on the screen return to their defaults. Previously made settings are restored when you cancel the Easy Handycam operation.

[DEMO MODE] does not start.

- Eject the cassette and “Memory Stick Duo” from your camcorder (p. 17, 18).

The camcorder gets warm.

- The camcorder may get warmer while you use it. This is not a malfunction.

Batteries/Power sources

The power abruptly turns off.

- When approximately 5 minutes have elapsed while you do not operate your camcorder, the camcorder is automatically turned off (A.SHUT OFF). Change the setting of [A.SHUT OFF] (p. 58), or turn on the power again (p. 13), or use the AC Adaptor.
- Charge the battery pack (p. 9).

The CHG (charge) lamp does not light while the battery pack is being charged.

- Slide the POWER switch up to (CHG) OFF (p. 10).
- Attach the battery pack to the camcorder correctly (p. 9).
- No power is supplied from the wall outlet. (p. 9).
- Insert your camcorder into the Handycam Station correctly (p. 10).
- The battery charge is completed (p. 10).

The CHG (charge) lamp flashes while the battery pack is being charged.

- Attach the battery pack to the camcorder correctly. If the problem persists, disconnect the AC Adaptor from the wall outlet and contact your Sony dealer. The battery pack may be damaged.

The power turns off frequently although the remaining battery time indicator indicates that the battery pack has enough power to operate.

- A problem has occurred in the remaining battery time indicator, or the battery pack has not been charged enough. Fully charge the battery again to correct the indication (p. 9).

The remaining battery time indicator does not indicate the correct time.

- The temperature of the environment is too high or too low, or the battery pack has not been charged enough. This is not a malfunction.
- Fully charge the battery again. If the problem persists, replace the battery pack with a new one. It may be damaged (p. 9, 110).
- The indicated time may not be correct depending on the environment of use. When you open or close the LCD panel, it takes about 1 minute to display the correct remaining battery time.

The battery pack is quickly discharged.

- The temperature of the environment is too high or low, or the battery pack has not been charged enough. This is not a malfunction.
- Fully charge the battery again. If the problem persists, replace the battery pack with a new one. It may be damaged (p. 9, 110).

A problem occurs when the camcorder is connected to the AC Adaptor.

- Turn off the power, and disconnect the AC Adaptor from the wall outlet. Then, connect it again.

LCD screen/viewfinder

An unknown picture appears on the LCD screen or viewfinder.

- The camcorder is in [DEMO MODE] (p. 52). Touch the LCD screen or insert a cassette or a “Memory Stick Duo” to cancel [DEMO MODE].

An unknown indicator appears on the screen.

- Refer to the indicator list (p. 101).

The picture remains on the LCD screen.

- This occurs if you disconnect the AC Adaptor from the wall outlet or remove the battery pack without turning off the power first. This is not a malfunction.

You cannot turn the LCD backlight off.

- During Easy Handycam operation (p. 20), you cannot turn the LCD backlight on/off using the DISPLAY BATT INFO.

The buttons do not appear on the touch panel.

- Touch the LCD screen lightly.
- Press DISPLAY BATT INFO on your camcorder (or DISPLAY on the Remote Commander) (p. 15).

The buttons on the touch panel do not work correctly or do not work at all.

- Adjust the screen ([CALIBRATION]) (p. 114).
- If you change the aspect ratio of the picture, the aspect ratio of the buttons of the touch panel and indicators will switch to the selected one (p. 19).

The picture in the viewfinder is not clear.

- Use the viewfinder lens adjustment lever to adjust the lens (p. 14).

The picture in the viewfinder has disappeared.

- Close the LCD panel. The picture is not displayed in the viewfinder when the LCD panel is open (p. 14).

Cassette tapes

The cassette cannot be ejected from the compartment.

- Make sure the power source (battery pack or AC Adaptor) is connected correctly (p. 9).
- Remove the battery pack from the camcorder, then attach it again (p. 11).
- Attach a charged battery pack to the camcorder (p. 9).

The cassette is not ejected even when the cassette lid is open.

- Moisture condensation is starting in your camcorder (p. 113).

The Cassette Memory indicator or title display does not appear while using a cassette with Cassette Memory.

- This camcorder does not support Cassette Memory, so the indicator does not appear.

The remaining tape indicator is not displayed.

- Set [REMAINING] to [ON] to always display the remaining tape indicator (p. 57).

The cassette is noisier during rewinding or fast-forwarding.

- When using the AC adaptor, rewind/fast forward speed increases (compared with battery operation) and therefore increases noise.

“Memory Stick Duo”

You cannot operate functions using the “Memory Stick Duo.”

- Slide the POWER switch down to turn on the CAMERA-MEMORY or PLAY/EDIT lamp (p. 13).
- Insert a “Memory Stick Duo” into your camcorder (p. 18).
- If you use a “Memory Stick Duo” formatted on a computer, format it on your camcorder (p. 108).

The picture is played back in the wide angle mode.

- The recording angle when the power switch is set to CAMERA-MEMORY is wider than when it is set to CAMERA-TAPE.

Pictures cannot be deleted.

- Release the lock on the write-protect tab of the “Memory Stick Duo.” (p. 108)
- Cancel image protection on the picture (p. 69).
- The maximum number of pictures that you can delete at one time is 100.

You cannot delete all pictures at once.

- Release the lock on the write-protect tab of the “Memory Stick Duo.” (p. 108)
- Cancel image protection on the pictures (p. 69).

You cannot format the “Memory Stick Duo.”

- Release the lock on the write-protect tab of the “Memory Stick Duo.” (p. 108)

Image protection cannot be applied.

- Release the lock on the write-protect tab of the “Memory Stick Duo.” (p. 108)
 - Perform the operation again on the index screen (p. 69).
-

You cannot mark pictures for print.

- Release the lock on the write-protect tab of the “Memory Stick Duo.” (p. 108)
 - Perform the operation again on the index screen (p. 70).
 - The maximum number of pictures you can mark for print is 999.
 - Movies cannot be marked for print.
-

The data file name is not indicated correctly.

- Only the file name is displayed if the directory structure does not conform to the universal standard.
 - The file is damaged.
 - The file format is not supported on your camcorder (p. 108).
-

The data file name flashes.

- The file is damaged.
 - The file format is not supported on your camcorder (p. 108).
-

Recording

Refer also to “Adjusting the image during recording” (p. 92) and “Memory Stick Duo” section (p. 89).

The tape does not start when you press REC START/STOP.

- Slide the POWER switch down to turn on the CAMERA-TAPE lamp (p. 22).
 - The tape has reached the end. Rewind it, or insert a new cassette.
 - Set the write-protect tab to REC or insert a new cassette (p. 107).
 - The tape is stuck to the drum due to moisture condensation. Remove the cassette and leave your camcorder for at least 1 hour, then re-insert the cassette (p. 113).
-

You cannot record on the “Memory Stick Duo.”

- Release the lock on the write-protect tab of the “Memory Stick Duo.” (p. 108)
- The capacity is full. Delete unnecessary pictures recorded on the “Memory Stick Duo.” (p. 69)
- Format the “Memory Stick Duo” on your camcorder or insert another “Memory Stick Duo.” (p. 47)
- In the following settings, still images cannot be recorded on a “Memory Stick Duo” during tape recording.
 - [PROGRES.REC]
 - [SMTH INT.REC]

You cannot record a smooth transition on a tape from the last recorded scene to the next.

- Note the following.
 - Perform END SEARCH. (p. 31)
 - Do not remove the cassette. (The picture will be recorded continuously without a break even when you turn the power off.)
 - Do not record pictures in SP mode and LP mode on the same tape.
 - Avoid stopping then recording a movie in the LP mode.

The shutter sound is not heard when you record a still image.

- Set [BEEP] to [ON] (p. 57).

The internal flash does not work.

- You cannot use the internal flash with:
 - [COLOR SLOW S]
 - [D. EFFECT]
 - [PROGRES.REC]
 - [BURST]
 - When the POWER switch is set to CAMERA-TAPE
- Even if auto flashing or  (Auto redeye reduction) is selected, you cannot use the internal flash with:
 - [SPOTLIGHT], [SUNSET&MOON], and [LANDSCAPE] of [PROGRAM AE]
 - [EXPOSURE]
 - [SPOT METER]
- When attaching a conversion lens (optional) or a filter (optional) to the camcorder, the flash light does not emit light since the flash light has been blocked.

The external flash (optional) does not work.

- The power of the flash is not turned on, or the flash is not attached correctly.
- The external flash (optional) does not work when the POWER switch is set to CAMERA-TAPE.

[END SEARCH] does not work.

- The cassette was ejected after recording (p. 31).
- The cassette is new and has nothing recorded.

[END SEARCH] does not work correctly.

- There is a blank section in the beginning or middle of the tape. This is not a malfunction.

Smooth interval recording stops/[Smooth interval rec discontinued due to error.] appears and recording stops.

- The video head may be dirty. Use a cleaning cassette (optional).
- Try again from the beginning.
- Use a Sony mini DV cassette.

Adjusting the image during recording

Refer also to “Menu” (p. 95).

The auto focus does not function.

- Set [FOCUS] to [AUTO] (p. 42).
- The recording conditions are not suitable for auto focus. Adjust the focus manually (p. 42).

[STEADYSHOT] does not function.

- Set [STEADYSHOT] to [ON] (p. 44).

The BACK LIGHT function does not function.

- The BACK LIGHT function is canceled when you set [EXPOSURE] to [MANUAL] (p. 40) or select [SPOT METER] (p. 40).
- The BACK LIGHT function does not work during Easy Handycam operation.

The [FLASH LEVEL] cannot be changed.

- [FLASH LEVEL] cannot be changed during Easy Handycam operation (p. 43).

[DIGITAL ZOOM] does not function.

- [DIGITAL ZOOM] does not function when you set [TELE MACRO] to [ON].

Tiny spots in white, red, blue, or green appear on the screen.

- The spots appear when you are recording in [SLOW SHUTTR], or [COLOR SLOW S]. This is not a malfunction.

The subjects passing by the frame might appear crooked.

- This is called the focal plane phenomenon. This is not a malfunction. Because of the way the image device (CMOS sensor) reads out image signals, the subjects passing by the frame rapidly might crooked depending on the recording conditions.

The picture appears too dark on the screen, and the subject does not appear on the screen.

- The LCD backlight is turned off. Press and hold DISPLAY BATT INFO for a few seconds to turn on the backlight (p. 14).

The picture appears bright, horizontal black bands appear, or changes in color occurs.

- This occurs when recording pictures under a fluorescent lamp, sodium lamp, or mercury lamp. This is not a malfunction. Cancel [PROGRAM AE] (p.40) or [PROGRES.REC] (p.44) to lessen the symptom.

Black bands appear when you record a TV screen or computer screen.

- Set [STEADYSHOT] to [OFF] (p. 44).

Playback

If you are playing back the pictures stored on a “Memory Stick Duo,” refer also to the “Memory Stick Duo” section (p. 89).

You cannot play back the tape.

- Slide the POWER switch down to turn on the PLAY/EDIT lamp.
- Rewind the tape (p. 23).

The pictures stored on a “Memory Stick Duo” are not played back in the actual size or aspect ratio.

- Pictures recorded on other devices may not appear in the actual size. This is not a malfunction.
- If you play back a movie recorded on the “Memory Stick Duo” with a 16:9 ratio, the black bands will appear at the top and bottom of the screen. This is not a malfunction.

Image data stored on a “Memory Stick Duo” cannot be played back.

- Image data cannot be played back if you have modified files or folders, or have edited the data on a computer. (The file name flashes in that case.) This is not a malfunction (p. 109).
- Pictures recorded on other devices may not be played back. This is not a malfunction (p. 109).

Horizontal lines appear on the picture. The displayed pictures are not clear or do not appear.

- Clean the head using the cleaning cassette (optional) (p. 113).

You cannot hear the sound recorded with 4CH MIC REC.

- Adjust [AUDIO MIX] (p. 54).

Fine patterns flicker, diagonal lines look jagged.

- Adjust [SHARPNESS] to the (soften) side (p. 41).

No sound or only a low sound is heard.

- Set [MULTI-SOUND] to [STEREO] (p. 54).
 - Turn up the volume (p. 23).
 - Adjust [AUDIO MIX] from the [ST2/REAR] (additional sound) side until the sound is heard appropriately (p. 68).
 - When you are using an S VIDEO plug, make sure the red and white plugs of the A/V connecting cable are connected as well (p. 34).
-

The sound breaks off.

- Clean the head using the cleaning cassette (optional) (p. 113).
-

“---” is displayed on the screen.

- The tape you are playing was recorded without setting the date and time.
 - A blank section on the tape is being played.
 - The data code on a tape with a scratch or noise cannot be read.
-

Noises appear and PAL is displayed on the screen.

- The tape was recorded in a TV color system other than that of your camcorder (NTSC). This is not a malfunction (p. 106).
-

Date Search does not work correctly.

- If one day's recording is less than 2 minutes, your camcorder may not accurately find the point where the recording date changes.
 - There is a blank section in the beginning or middle of the tape. This is not a malfunction.
-

Remote Commander

The supplied Remote Commander does not function.

- Set [REMOTE CTRL] to [ON] (p. 57).
 - Remove any obstructions between the Remote Commander and the remote sensor.
 - Point the remote sensor away from strong light sources such as direct sunlight or overhead lighting. Otherwise, the Remote Commander may not function properly.
 - Insert a new battery. Insert a battery into the battery holder with the +/- polarities correctly matching the +/- marks. (p. 115).
 - Remove the conversion lens (optional) as the remote sensor may be obstructed by it.
-

Another VCR malfunctions when you use the supplied Remote Commander.

- Select a commander mode other than VTR 2 for your VCR, or cover the sensor of your VCR with black paper.

Menu

Menu items are grayed out.

- You cannot select grayed items in the current recording/playback situation.

You cannot use [PROGRAM AE].

- You cannot use [PROGRAM AE] together with:
 - [COLOR SLOW S]
 - [TELE MACRO]

You cannot use [SPOT METER].

- You cannot use [SPOT METER] together with:
 - [COLOR SLOW S]
- If you set [PROGRAM AE], [SPOT METER] is automatically set to [AUTO].

You cannot use [EXPOSURE].

- You cannot use [EXPOSURE] together with:
 - [COLOR SLOW S]
 - [CINEMA EFFECT] in [D. EFFECT]
- If you set [PROGRAM AE], [EXPOSURE] is automatically set to [AUTO].

You cannot adjust [SHARPNESS].

- You cannot adjust [SHARPNESS] with [CINEMA EFFECT] of [D. EFFECT].

You cannot use [SPOT FOCUS].

- You cannot use [SPOT FOCUS] together with [PROGRAM AE].

You cannot use [TELE MACRO].

- You cannot use [TELE MACRO] together with:
 - [PROGRAM AE]
 - Recording a movie on a tape or “Memory Stick Duo.”

[COLOR SLOW S] does not operate correctly.

- You cannot use [COLOR SLOW S] together with:
 - [FADER]
 - [D. EFFECT]
 - [PROGRAM AE]
 - [EXPOSURE]
 - [SPOT METER]

You cannot use [PROGRES.REC].

- You cannot use [PROGRES.REC] with [CINEMA EFFECT] of [D. EFFECT].
-

You cannot use [FADER].

- You cannot use [FADER] together with:
 - [SELF-TIMER]
 - [COLOR SLOW S]
 - [D. EFFECT]
 - [FRAME REC]
 - [SMTH INT.REC]
-

You cannot use [D. EFFECT].

- You cannot use [D. EFFECT] together with:
 - [COLOR SLOW S]
 - [FADER]
 - You cannot use [CINEMA EFFECT], [SLOW SHUTTR], and [OLD MOVIE] together with [PROGRAM AE] (except [AUTO]).
 - You cannot use [OLD MOVIE] together with:
 - [PICT. EFFECT]
 - You cannot use [CINEMA EFFECT] together with:
 - [EXPOSURE] set to [MANUAL]
 - Other than 0 in [AE SHIFT]
 - [PROGRES.REC]
 - [PICT. EFFECT]
-

You cannot use [SMTH INT.REC].

- You cannot use [SMTH INT.REC] when you use [CINEMA EFFECT] or [DELAY MOTION] from [D. EFFECT].
-

You cannot use [SKINTONE] on the [PICT. EFFECT] menu.

- [PICT. EFFECT] cannot be set to [SKINTONE] while using the BACK LIGHT function.
-

[HISTOGRAM] is not displayed.

- [HISTOGRAM] is not displayed in the following.
 - While using [EXP.FOCUS]
 - While displaying the date and time
 - While operating the camcorder with Easy Handycam operation
 -  indicator appears and [HISTOGRAM] is not displayed in the following.
 - While using [DIGITAL ZOOM]
 - While using [D.EFFECT]
-

[AE SHIFT] cannot be operated.

- [AE SHIFT] cannot be selected when [EXPOSURE] is set to [MANUAL].

Dubbing/Editing/Connecting to other devices

Pictures output from the camcorder do not appear on the screen of the connected device.

- When attaching the camcorder to the Handycam Station, close the DC IN jack cover on the camcorder, and then fully insert the camcorder into the Handycam Station in the correct direction securely (p. 10).

Pictures from connected devices are not displayed on the LCD screen or the viewfinder.

- Set [DISP OUTPUT] to [LCD PANEL] (p. 57).
- You cannot input a signal to your camcorder if you press DISPLAY BATT INFO while [DISP OUTPUT] is set to [V-OUT/PANEL] (p. 57).

Pictures from connected devices cannot be zoomed.

- You cannot zoom the pictures from connected devices on your camcorder (p. 26).

Time code and other information appear on the display of the connected device.

- Set [DISP OUTPUT] to [LCD PANEL] while connected with an A/V connecting cable (p. 57).

You cannot dub correctly using the A/V connecting cable.

- Set [DISP OUTPUT] to [LCD PANEL] (p. 57).
- The A/V connecting cable is not connected properly. Make sure that the A/V connecting cable is connected to the proper jack, i.e. to the output jack of a device you are dubbing a picture from, or to the input jack of another device for dubbing a picture from your camcorder.

New sound added to a recorded tape is not heard.

- Adjust [AUDIO MIX] from the [ST1/FRONT] (original sound) side until the sound is heard appropriately (p. 68).

Still pictures cannot be dubbed from a tape to a “Memory Stick Duo.”

- You cannot record or a distorted picture may be recorded if the tape has been used repeatedly for recording.

Movies cannot be dubbed from a tape to a “Memory Stick Duo.”

- You cannot record or a distorted picture may be recorded in the following situations:
 - The tape has a blank section.
 - The tape has been used repeatedly for recording.
 - The input signal has been interrupted or cut.

You cannot input pictures.

- You cannot input pictures while [DISP OUTPUT] is set to [V-OUT/PANEL] (p. 57).
 - You cannot input pictures if you press the DISPLAY BATT INFO button.
-

The picture gets disturbed or dark, or the sounds get distorted.

- A/V connecting cables are connected to both your camcorder and the Handycam Station. Disconnect one of the A/V connecting cables.
-

Connecting to a computer



The computer does not recognize your camcorder.

- Disconnect the cable from the computer and camcorder, then connect it again securely.
 - Set the USB ON/OFF switch on the Handycam station to [ON] (only when connected using a USB cable (supplied)).
 - Insert you camcorder into the Handycam Station correctly (p. 10).
 - Disconnect USB devices other than the keyboard, the mouse, and the camcorder from the  (USB) jack on the computer.
 - Disconnect the cable from the computer and camcorder, restart the computer, then connect them again correctly.
-

An error message appears when you place the supplied CD-ROM in your computer.

- Set the computer display as follows:
 - Windows: 800 × 600 dots or more, High Color (16 bits, 65 000 colors or more)
 - Macintosh: 1 024 × 768 dots or more, 32 000 colors or more
-

You cannot monitor video that the camcorder is capturing.

- Disconnect the cable from the computer, turn on the camcorder, then connect it again.
- Slide the POWER switch down to turn on the CAMERA-TAPE lamp on your camcorder and select [DV STREAM] on the [USB CAMERA] menu. (Only when connecting to the Windows computer with a USB cable (supplied))
- The USB connection is available only with Windows XP Service Pack1 (SP1) or Service Pack2 (SP2) supporting High-Speed USB (USB 2.0) device.
- You cannot use DV STREAM via the USB connection and the i.LINK connection at the same time.

You cannot view the video recorded on a tape on the computer. [USB](#) [i.LINK](#)

- Disconnect the cable from the computer, then connect it again.
- Slide the POWER switch down to turn on the PLAY/EDIT lamp on your camcorder and select [DV STREAM] or [MULTI CONNCT] on the [USB SELECT] menu. (Only when connecting to the Windows computer with a USB cable (supplied))
- The USB connection is available only with Windows XP Service Pack1 (SP1) or Service Pack2 (SP2) supporting High-Speed USB (USB 2.0) device.
- You cannot use DV STREAM via the USB connection and the i.LINK connection at the same time.

You cannot view the video recorded on a tape on a Macintosh computer. [USB](#)

- When you connect your camcorder to a Macintosh computer using a USB cable (supplied), you cannot copy pictures recorded on a tape to the computer. To copy recordings from a tape, connect your camcorder to the computer with an i.LINK cable (optional) and use the standard software in the OS.

You cannot view the video and still images recorded on a “Memory Stick Duo” on the computer. [USB](#)

- Insert a “Memory Stick Duo” in the correct direction, then push it all the way in.
- You cannot use an i.LINK cable (optional). Connect the camcorder and the computer using the USB cable (supplied).
- Slide the POWER switch down to turn on the PLAY/EDIT lamp on your camcorder and set [USB SELECT] to [MEMORY STICK] on the menu (p. 52).
- The computer does not recognize the “Memory Stick Duo” during camcorder operations such as tape playback or editing. Finish any camcorder operations before connecting the camcorder to the computer.

The “Memory Stick” icon ([Removable Disk] or [Sony MemoryStick]) does not appear on the computer screen. [USB](#)

- Slide the POWER switch down to turn on the PLAY/EDIT lamp on your camcorder.
- Insert a “Memory Stick Duo” into your camcorder.
- Disconnect the USB device other than the keyboard, the mouse, and the camcorder from the  (USB) jack on the computer.
- Slide the POWER switch down to turn on the PLAY/EDIT lamp and set [USB SELECT] to [MEMORY STICK] on the menu (p. 52).
- The computer does not recognize the “Memory Stick Duo” during camcorder operations such as tape playback or editing. Finish camcorder operations before connecting the camcorder to the computer.

You cannot copy video and still images to the Windows computer. USB

- Display pictures recorded on a “Memory Stick Duo” with the following procedures.
 - 1 Double-click [My Computer].
 - 2 Double-click the icon for the newly recognized drive [Removable Disk (F:)] ([Sony MemoryStick]). It may take some time until the drive is recognized. If the computer does not recognize it, the USB driver may be installed incorrectly.
 - 3 Double-click the desired image file.
-

[Cannot start Easy Handycam with USB connected] or [Cannot cancel Easy Handycam with USB connected] appears on the screen of your camcorder. USB

- You cannot start or cancel the Easy Handycam settings while the USB cable (supplied) is connected. Disconnect the USB cable (supplied) from your camcorder first.
-

Picture Package does not function correctly.

- Close Picture Package, then restart the computer.
-

An error message appears while operating Picture Package.

- Close Picture Package first, then slide the POWER switch on your camcorder to turn on another lamp.
-

The CD-R drive is not recognized or data cannot be written on the CD-R in Picture Package Auto Video, Producer, CD Backup, or VCD Maker.

- For compatible drives, visit the following URL:
<http://www.ppackage.com/>
-

“First Step Guide” is not displayed correctly.

- Follow the procedure below and refer to “First Step Guide” (FirstStepGuide.pdf).
 - 1 Place the supplied CD-ROM in the disc drive of your computer.
 - 2 Double-click [My Computer].
 - 3 Right-click [PICTUREPACKAGE] (Disc drive)*.
 - * Drive names (such as (E:)) may vary depending on the computer.
 - 4 Click [Explorer].
 - 5 Double-click [FirstStepGuide].
 - 6 Double-click the desired language folder.
 - 7 Double-click “FirstStepGuide.pdf.”

Warning indicators and messages

Self-diagnosis display/Warning indicators

If indicators appear on the LCD screen or in the viewfinder, check the following. Some symptoms you can fix by yourself. If the problem persists even after you have tried a couple of times, contact your Sony dealer or local authorized Sony service facility.

C:(or E:) □□:□□ (Self-diagnosis display)

C:04:□□

- The battery pack is not an “InfoLITHIUM” battery pack. Use an “InfoLITHIUM” battery pack (p. 110).

C:21:□□

- Moisture condensation has occurred. Remove the cassette and leave your camcorder for at least 1 hour, then reinsert the cassette (p. 113).

C:22:□□

- Clean the head using a cleaning cassette (optional) (p. 113).

C:31:□□ / C:32:□□

- Symptoms that are not described above have occurred. Remove and insert the cassette, then operate your camcorder again. Do not perform this procedure if moisture starts to condense (p. 113).
- Remove the power source. Reconnect it again and operate your camcorder again.
- Change the cassette. Press RESET (p. 26), and operate your camcorder again.

E:61:□□ / E:62:□□ / E:91:□□

- Contact your Sony dealer or local authorized Sony service facility. Inform them of the 5-digit code, which starts from “E.”

101-1001(Warning indicator pertaining to files)

- The file is damaged.

- The file is unreadable (p. 108).

(Battery level warning)

- The battery pack is nearly used up.
- Depending on the operating, environment, or battery conditions,  may flash, even if there are approximately 5 to 10 minutes remaining.

(Moisture condensation warning)*

- Eject the cassette, remove the power source, and then leave it for about 1 hour with the cassette lid open (p. 113).

(Warning indicator pertaining to “Memory Stick Duo”)

- “Memory Stick Duo” is not inserted (p. 18).

(Warning indicators pertaining to “Memory Stick Duo”)*

- The “Memory Stick Duo” is damaged.
- The “Memory Stick Duo” is not formatted correctly (p. 47).

(Warning indicator pertaining to incompatible “Memory Stick Duo”)*

- An incompatible “Memory Stick Duo” is inserted (p. 108).

(Warning indicators pertaining to the tape)

Slow flashing:

- There is less than 5 minutes remaining on the tape.
- No cassette is inserted.*
- The write-protect tab on the cassette is set to lock (p. 107).*

Fast flashing:

- The tape has run out.*

(Eject cassette warning)*

Slow flashing:

- The write-protect tab on the cassette is set to lock (p. 107).

Fast flashing:

- Moisture condensation has occurred (p. 113).
- The self-diagnosis display code is displayed (p. 101).

(Warning indicator pertaining to image deletion)*

- The image is protected (p. 69).

(Warning indicator pertaining to the write-protect of the “Memory Stick Duo”)*

- The write-protect tab on the “Memory Stick Duo” is set to lock (p. 108).

(Warning indicator pertaining to the flash)

Slow flashing:

- Still charging

Fast flashing:

- The self-diagnosis display code is displayed (p. 101).*
- There is something wrong with the flash.

(Warning indicator pertaining to camera-shake warning)

- The amount of lights is not sufficient, so camera-shake easily occurs. Use the flash.
- The camcorder is unsteady, so camera-shake easily occurs. Hold the camcorder steady with both hands and shoot the image. However, note that the camera-shake warning indicator does not disappear.

* You hear a melody when the warning indicators appear on the screen (p. 57).

Description of warning messages

If messages appear on the screen, follow the instructions.

Battery

Use the “InfoLITHIUM” battery pack (p. 110).

Battery level is low.

- Change the battery (p. 9, 110)

Old battery. Use a new one (p. 110).

 Re-attach the power source (p. 9).

Moisture condensation

  Moisture condensation. Eject the cassette (p. 113)

 Moisture condensation. Turn off for 1H (p. 113).

Cassette/Tape

 Insert a cassette (p. 17).

 Reinsert the cassette.

- Check if the cassette is damaged.

  The tape is locked - check the tab (p. 107).

 **The tape has reached the end.**

- Rewind or change the tape.

■ **“Memory Stick Duo”**

 **Insert a Memory Stick** (p. 18).

 **Reinsert the Memory Stick.**

- Reinsert the “Memory Stick Duo” a few times. If even then the indicator flashes, the “Memory Stick Duo” might be damaged. Try with another “Memory Stick Duo.”

This is a read-only Memory Stick.

- Insert a writable “Memory Stick Duo.”

 **Incompatible type of Memory Stick.**

- A type of “Memory Stick Duo” incompatible with your camcorder is inserted (p. 108).

 **This Memory Stick is not formatted correctly.**

- Check the format, then format the “Memory Stick Duo” as necessary (p. 47, 108).

Cannot record. The Memory Stick is full.

- Delete unnecessary images (p. 69).

 **The Memory Stick is locked. Check the tab** (p. 108).

Cannot playback. Reinsert the Memory Stick (p. 18).

Cannot record. Reinsert the Memory Stick (p. 18).

No file.

- No file is recorded or there is no readable file on the “Memory Stick Duo.”

Memory Stick folders are full.

- You cannot create folders exceeding 999MSDCF. You cannot delete created folders using your camcorder.
- You will have to format the “Memory Stick Duo” (p. 47), or delete them using your computer.

Cannot record still images on Memory Stick (p. 108).

Cannot record movies on Memory Stick (p. 108).

■ **PictBridge compliant printer**

Check the connected device.

- Switch off the printer and switch it on again, then disconnect the USB cable (supplied) and reconnect it.

Connect the camcorder to a PictBridge compatible printer.

- Switch off the printer and switch it on again, then disconnect the USB cable (supplied) and reconnect it.

Error. Cancel the task.

- Check the printer.

Cannot print. Check the printer.

- Switch off the printer and switch it on again, then disconnect the USB cable (supplied) and reconnect it.

■ Flash

Charging... Cannot record still images.

- You are trying to record a still image while charging the flash (optional).

Lens accessory attached. Cannot use flash.

- A conversion lens (optional) or a filter (optional) is attached to your camcorder, the flash light does not emit light (p. 91).

■ Lens cover

Lens cover not fully open. Turn power off then on (p.22).

Lens cover is not closed. Turn the power off once (p. 13).

■ Others

Cannot record due to copyright protection (p. 107).

Cannot add audio. Disconnect the i.LINK cable (p. 67).

Not recorded in SP mode. Cannot add audio (p. 67).

Not recorded in 12-bit audio. Cannot add audio (p. 67).

Cannot add audio on the blank portion of a tape (p. 67).

Cannot add audio (p. 68).

- You cannot add sound to the tape recorded with 4CH MIC REC.

Cannot use 4CH MIC REC (p. 55).

- Disconnect the external 4CH microphone (optional) once, then connect it again.

Dirty video head. Use a cleaning cassette (p. 113).

Cannot start Easy Handycam. Cannot cancel Easy Handycam (p. 86).

USB is invalid in this mode during Easy Handycam

- You cannot use USB when the POWER switch is set to CAMERA-TAPE.

HDV recorded tape. Cannot playback.

- Your camcorder cannot play back this format. Play back the tape with the equipment that recorded it.

HDV recorded tape. Cannot add audio.

- Your camcorder does not allow you to add audio on a section of a tape recorded in HDV format.

Disconnect one AV cable.

- A/V connecting cables are connected to both the camcorder and the Handycam Station. Disconnect one of them.

i.LINK connected. No DV streaming by USB.

- You cannot perform DV streaming using the USB connection while using the i.LINK connection. Finish the DV streaming, disconnect the i.LINK cable (optional), then connect the USB cable (supplied) (p. 52).

DV streaming by USB... Cannot use i.LINK.

- The i.LINK connection cannot be used while performing DV streaming using USB function. Finish the DV streaming, disconnect the USB cable (supplied), then connect the i.LINK cable (optional) (p. 52).

Hi-Speed USB not supported. No DV streaming by USB.

- DV movie streaming is only compatible with Windows XP Service Pack1 (SP1) or Service Pack2 (SP2) supporting High-Speed USB (USB 2.0) device (p.52).

Using your camcorder abroad

Power supply

You can use your camcorder in any countries/regions using the AC Adaptor supplied with your camcorder within the AC 100 V to 240 V, 50/60 Hz range. Use a commercially available AC plug adaptor [a], if necessary, depending on the design of the wall outlet [b].



AC-L200

[a] [b]

On TV color systems

Your camcorder is an NTSC system-based camcorder. If you want to view the playback picture on a TV, it must be an NTSC system based TV (see the following list) with an AUDIO/VIDEO input jack.

System	Used in
NTSC	Bahama Islands, Bolivia, Canada, Central America, Chile, Colombia, Ecuador, Guyana, Jamaica, Japan, Korea, Mexico, Peru, Surinam, Taiwan, the Philippines, the U.S.A., Venezuela, etc.
PAL	Australia, Austria, Belgium, China, Czech Republic, Denmark, Finland, Germany, Holland, Hong Kong, Hungary, Italy, Kuwait, Malaysia, New Zealand, Norway, Poland, Portugal, Singapore, Slovak Republic, Spain, Sweden, Switzerland, Thailand, United Kingdom, etc.
PAL - M	Brazil
PAL - N	Argentina, Paraguay, Uruguay.
SECAM	Bulgaria, France, Guiana, Iran, Iraq, Monaco, Russia, Ukraine, etc.

Simple setting of the clock by time difference

You can easily set the clock to the local time by setting a time difference when using your camcorder abroad. Select [WORLD TIME] in the  (TIME/LANGU.) menu, then set the time difference (p. 58).

Usable cassette tapes

You can use mini DV format cassettes only. Use a cassette with the ^{Mini}DV mark.

Mini DV ^{Digital Video Cassette} is a trademark.

Your camcorder is not compatible with cassettes with Cassette Memory.

To prevent a blank section from being made on the tape

Go to the end of the recorded section using END SEARCH (p. 31) before you begin the next recording in the following cases:

- You have played back the tape.
- You have used EDIT SEARCH.

Copyright signal

■ When you play back

If the cassette you play back on your camcorder contains copyright signals, you cannot copy it to a tape in another video camera connected to your camcorder.

■ When you record

You cannot record software on your camcorder that contains copyright control signals for copyright protection of software. [Cannot record due to copyright protection.] appears on the LCD screen, or on the viewfinder if you try to record such software. Your camcorder does not record copyright control signals on the tape when it records.

Notes on use

■ When not using your camcorder for a long time

Remove the cassette and store it.

■ To prevent accidental erasure

Slide the write-protect tab on the cassette to set it to SAVE.

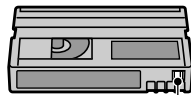

REC: The cassette can be recorded.

SAVE: The cassette cannot be recorded (write-protected).



■ When labeling the cassette

Be sure to place the label only on the locations shown in the following illustration so as not to cause a malfunction of your camcorder.

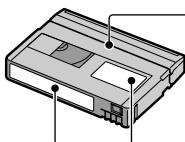

Do not put a label along this border.

Labeling position

■ After using the cassette

Rewind the tape to the beginning to avoid distortion of the picture or the sound. The cassette should then be put in its case, and stored in an upright position.

■ When cleaning the gold-plated connector

Generally, clean the gold-plated connector on a cassette with a cotton-wool swab after every 10 times it has been ejected. If the gold-plated connector on the cassette is dirty or dusty, the remaining tape indicator may not be indicated correctly.

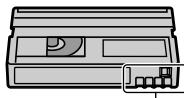

Gold-plated connector

About the “Memory Stick”

A “Memory Stick” is a compact, portable IC recording medium with a data capacity that exceeds the capacity of a floppy disk. You can use only a “Memory Stick Duo,” which is about the half size of a standard “Memory Stick” in your camcorder. However, appearance on the list below does not guarantee the operation of all types of “Memory Stick Duo” in your camcorder.

Types of “Memory Stick”	Recording/ Playback
“Memory Stick”	–
“Memory Stick Duo” ¹	○
“MagicGate Memory Stick”	–
“Memory Stick Duo” (MagicGate/Parallel Transfer) ¹	○ ^{2,3}
“MagicGate Memory Stick Duo” ¹	○ ³
“Memory Stick PRO”	–
“Memory Stick PRO Duo” ¹	○ ^{2,3}

¹A “Memory Stick Duo” is about half the size of a standard “Memory Stick.”

²The types of “Memory Stick” that support high speed data transfer. The speed of data transfer varies depending on the device to be used.

³“MagicGate” is a copyright protection technology that records and transfers the contents in an encrypted format. Note that data that uses “MagicGate” technology cannot be recorded or played on your camcorder.

- Still image format: Your camcorder compresses and records image data in the JPEG (Joint Photographic Experts Group) format. The file extension is “.JPG.”
- Movie format: Your camcorder compresses and records picture data in the MPEG (Moving Picture Experts Group) format. The file extension is “.MPG.”
- File names of still images:
 - 101- 0001: This file name appears on the screen of your camcorder.
 - DSC00001.JPG: This file name appears on the display of a computer.
- File names of movies:

- MOV00001: This file name appears on the screen on your camcorder.
- MOV00001.MPG: This file name appears on the display of a computer.
- A “Memory Stick Duo” formatted by a computer (Windows OS/Mac OS) does not have guaranteed compatibility with your camcorder.
- Data read/write speed may vary depending on the combination of the “Memory Stick” and “Memory Stick” compliant product you use.

On a “Memory Stick Duo” with a write-protect tab

You can prevent accidental erasure of images when you slide the write-protect tab on the “Memory Stick Duo” with a small tapered object, to the write-protect position. The “Memory Stick Duo” supplied with your camcorder is not equipped with a write-protect tab.

Notes on use

Image data may be damaged in the following cases. Compensation for damaged image data will not be made.

- If you eject the “Memory Stick Duo,” turn the power off on your camcorder, or remove the battery pack for replacement while your camcorder is reading or writing image files on the “Memory Stick Duo” (while the access lamp is lit or flashing).
- If you use the “Memory Stick Duo” near magnets or magnetic fields.

It is recommended you make a back-up of important data on the hard disk of a computer.

■ On handling a “Memory Stick”

Keep the following in mind when handling a “Memory Stick Duo.”

- Be careful not to apply excessive force when writing on a memo area on a “Memory Stick Duo.”
- Do not attach a label or the like on a “Memory Stick Duo” or a Memory Stick Duo adaptor.
- When you carry or store a “Memory Stick Duo,” put it in its case.
- Do not touch, or allow metallic objects to come into contact with the terminals.
- Do not bend, drop or apply strong force to the “Memory Stick Duo.”
- Do not disassemble or modify the “Memory Stick Duo.”
- Do not let the “Memory Stick Duo” get wet.
- Be careful to keep “Memory Stick Duo” media out of the reach of small children. There is danger that a child might swallow it.

■ On a location for use

Do not use or keep the “Memory Stick Duo” in the following locations.

- Places subject to extremely high temperature, such as a car parked outside in the summer.
- Places under direct sunlight.
- Places with extremely high humidity or subject to corrosive gases.

■ On the Memory Stick Duo adaptor (supplied)

After inserting a “Memory Stick Duo” into the Memory Stick Duo adaptor, you can use it with a standard “Memory Stick” compliant device.

- When using a “Memory Stick Duo” with a “Memory Stick” compliant device, be sure to insert the “Memory Stick Duo” into a Memory Stick Duo adaptor.
- When inserting a “Memory Stick Duo” into a Memory Stick Duo adaptor, make sure the “Memory Stick Duo” is inserted facing in the correct direction, then insert it all the way in. Note that improper use may damage the device. Also, if you force the “Memory Stick Duo” into the “Memory Stick Duo” slot in the wrong direction, the “Memory Stick Duo” slot may be damaged.
- Do not insert anything other than a “Memory Stick Duo” into the “Memory Stick Duo” slot. Doing so may cause a malfunction.

- Do not insert a Memory Stick Duo adaptor without a “Memory Stick Duo” attached. Doing so may result in malfunctions of the unit.

■ On a “Memory Stick PRO Duo”

- The maximum memory capacity of a “Memory Stick PRO Duo” that can be used on your camcorder is 1 GB.

On image data compatibility

- Image data files recorded on a “Memory Stick Duo” by your camcorder conform to the Design Rule for Camera File Systems universal standard established by the JEITA (Japan Electronics and Information Technology Industries Association).
- On your camcorder, you cannot play back still images recorded on other devices (DCR-TRV900 or DSC-D700/D770) that do not conform to the universal standard. (These models are not sold in some regions.)
- If you cannot use a “Memory Stick Duo” that has been used with another device, format it with your camcorder (p. 47). Note that formatting erases all information on the “Memory Stick Duo.”
- You may not be able to play back images with your camcorder:
 - When playing back image data modified on your computer.
 - When playing back image data recorded with other devices.

About the “InfoLITHIUM” battery pack

This unit is compatible with an “InfoLITHIUM” battery pack (A series). Your camcorder operates only with an “InfoLITHIUM” battery pack. “InfoLITHIUM” A series battery packs have the  mark.

What is an “InfoLITHIUM” battery pack?

An “InfoLITHIUM” battery pack is a lithium-ion battery pack that has functions for communicating information related to operating conditions between your camcorder and an optional AC Adaptor/charger.

The “InfoLITHIUM” battery pack calculates the power consumption according to the operating conditions of your camcorder, and displays the remaining battery time in minutes.

To charge the battery pack

- Be sure to charge the battery pack before you start using your camcorder.
- We recommend charging the battery pack in an ambient temperature of between 50 °F to 86 °F (10°C to 30°C) until the CHG (charge) lamp turns off. If you charge the battery pack outside of this temperature range, you may not be able to charge it efficiently.

To use the battery pack effectively

- Battery pack performance decreases when the surrounding temperature is 10°C (50 °F) or below, and the length of time you can use the battery pack becomes shorter. In that case, do one of the following to use the battery pack for a longer time.
 - Put the battery pack in a pocket to warm it up, and insert it in your camcorder right before you start taking shots.
 - Use a large capacity battery pack: NP-FA70 (optional).

- Frequent use of the LCD screen or a frequent playback, fast forward or rewind operation wears out the battery pack faster. We recommend using a large capacity battery pack: NP-FA70 (optional).
- Be sure to set the POWER switch to (CHG) OFF when not recording or playing back on your camcorder. The battery pack is also consumed when your camcorder is in recording standby or playback pause.
- Have spare battery packs ready for two or three times the expected recording time, and make trial recordings before making the actual recording.
- Do not expose the battery pack to water. The battery pack is not water resistant.

About the remaining battery time indicator

- When the power goes off even though the remaining battery time indicator indicates that the battery pack has enough power to operate, charge the battery pack fully again. The indication on the remaining battery time will be indicated correctly. Note, however, that the battery indication will not be restored if it is used in high temperatures for a long time, or if left in a fully charged state, or when the battery pack is frequently used. Use the remaining battery time indication as a guide to the approximate shooting time.
- The  mark that indicates low battery flashes even if there are still 5 to 10 minutes of battery time remaining, depending on the operating conditions or ambient temperature and environment.

About storage of the battery pack

- If the battery pack is not used for a long time, fully charge the battery pack and use it up on your camcorder once a year to maintain proper function. To store the battery pack, remove it from your camcorder and put it in a dry, cool place.
- To discharge the battery pack on your camcorder completely, set [A.SHUT OFF] to [NEVER] on the  (STANDARD SET) menu and leave your camcorder in tape recording standby until the power goes off (p. 58).

About i.LINK

About battery life

- The battery life is limited. Battery capacity drops little by little as you use it more and more, and as time passes. When the available battery time is shortened considerably, a probable cause is that the battery pack has reached the end of its life. Please buy a new battery pack.
- The battery life varies depending on how it is stored and the operating conditions and environment for each battery pack.

The DV Interface on this unit is an i.LINK-compliant DV Interface. This section describes the i.LINK standard and its features.

What is i.LINK?

i.LINK is a digital serial interface for transferring digital video, digital audio, and other data to other i.LINK-compatible devices. You can also control other devices using the i.LINK.

i.LINK-compatible devices can be connected using an i.LINK cable (optional). Possible applications are operations and data transactions with various digital AV devices.

When two or more i.LINK-compatible devices are connected to this unit in a daisy chain, operations and data transactions are possible with not only the device that this unit is connected to but also with other devices via the directly connected device. Note, however, that the method of operation sometimes varies according to the characteristics and specifications of the device to be connected. Also, operations and data transactions may not be possible on some connected devices.

- Normally, only one device can be connected to this unit with the i.LINK cable (optional). When connecting this unit to an i.LINK-compatible device having two or more DV Interfaces, refer to the operating instructions of the device to be connected.
- i.LINK is a more familiar term for the IEEE 1394 data transport bus proposed by Sony, and is a trademark approved by many corporations.
- IEEE 1394 is an international standard standardized by the Institute of Electrical and Electronics Engineers.

About the i.LINK Baud rate

i.LINK's maximum baud rate varies according to the device. There are three types.

S100 (approx. 100Mbps*)

S200 (approx. 200Mbps)

S400 (approx. 400Mbps)

The baud rate is listed under “Specifications” in the operating instructions of each piece of equipment. It is also indicated near the i.LINK interface on some devices.

The baud rate may differ from the indicated value when the unit is connected to a device with a different maximum baud rate.

* What is Mbps?

Mbps stands for “megabits per second,” or the amount of data that can be sent or received in one second. For example, a baud rate of 100 Mbps means that 100 megabits of data can be sent in one second.

To use i.LINK functions on this unit

For details on how to dub when this unit is connected to other video devices having a DV Interface, see page 63.

This unit can also be connected to other i.LINK (DV Interface) compatible devices made by Sony (e.g. a VAIO series personal computer) as well as to video devices. Before connecting this unit to your computer, make sure that application software supported by this unit is already installed on your computer.

Some i.LINK compatible video devices, such as Digital Televisions, DVD, MICROMV or HDV recorders/players are not compatible with DV devices. Before connecting to other devices, be sure to confirm whether the device is compatible with a DV device or not. For details on precautions and compatible application software, refer also to the operating instructions for the device to be connected.

About the required i.LINK cable

Use the Sony i.LINK 4-pin-to-4-pin cable (during DV dubbing).

Maintenance and precautions

On use and care



- Do not use or store the camcorder and accessories in the following locations.
 - Anywhere extremely hot or cold. Never leave them exposed to temperatures above 60°C (140 °F), such as under direct sunlight, near heaters or in a car parked in the sun. They may malfunction or become deformed.
 - Near strong magnetic fields or mechanical vibration. The camcorder may malfunction.
 - Near strong radio waves or radiation. The camcorder may not be able to record properly.
 - Near AM receivers and video equipment. Noise may occur.
 - On a sandy beach or anywhere dusty. If sand or dust gets in your camcorder, it may malfunction. Sometimes this malfunction cannot be repaired.
 - Near windows or outdoors, where the LCD screen, the viewfinder, or the lens may be exposed to direct sunlight. This damages the inside of the viewfinder or the LCD screen.
 - Anywhere very humid.
- Operate your camcorder on DC 7.2 V (battery pack) or DC 8.4 V (AC Adaptor).
- For DC or AC operation, use the accessories recommended in these operating instructions.
- Do not let your camcorder get wet, for example, from rain or sea water. If your camcorder gets wet, it may malfunction. Sometimes this malfunction cannot be repaired.
- If any solid object or liquid gets inside the casing, unplug your camcorder and have it checked by a Sony dealer before operating it any further.
- Avoid rough handling, disassembling, modifying, physical shock, or impact such as hammering, dropping or stepping on the product. Be particularly careful of the lens.
- Keep the POWER switch setting to (CHG) OFF when you are not using your camcorder.
- Do not wrap your camcorder with a towel, for example, and operate it. Doing so might cause heat to build up inside.
- When disconnecting the power cord, pull it by the plug and not the cord.
- Do not damage the power cord such as by placing anything heavy on it.
- Keep metal contacts clean.

- Keep the Remote Commander and button-type battery out of children's reach. If the battery is accidentally swallowed, consult a doctor immediately.
- If the battery electrolytic liquid has leaked,
 - consult your local authorized Sony service facility.
 - wash off any liquid that may have contacted your skin
 - if any liquid gets in your eyes, wash with plenty of water and consult a doctor.



■ When not using your camcorder for a long time

- Occasionally turn it on and let it run such as by playing back tapes for about 3 minutes.
- Use up the battery pack completely before storing it.

Moisture condensation

If your camcorder is brought directly from a cold place to a warm place, moisture may condense inside your camcorder, on the surface of the tape, or on the lens. In this state, the tape may stick to the head drum and be damaged or your camcorder may not operate correctly. If there is moisture inside your camcorder, [▲ Moisture condensation. Eject the cassette.] or [ Moisture condensation. Turn off for 1H.] appears. The indicator will not appear when the moisture condenses on the lens.

■ If moisture condensation has occurred

None of the functions except cassette ejection will work. Eject the cassette, turn off your camcorder, and leave it for about one hour with the cassette lid open. Your camcorder can be used again if [] or [] does not appear when the power is turned on again.

If moisture starts to condense, your camcorder sometimes cannot detect condensation. If this happens, the cassette is sometimes not ejected for 10 seconds after the cassette lid is opened. This is not a malfunction. Do not close the cassette lid until the cassette is ejected.

■ Note on moisture condensation

Moisture may condense when you bring your camcorder from a cold place into a warm place (or vice versa) or when you use your camcorder in a humid place as shown below.

- When you bring your camcorder from a ski slope into a place warmed up by a heating device.
- When you bring your camcorder from an air conditioned car or room into a hot place outside.
- When you use your camcorder after a squall or a shower.
- When you use your camcorder in a hot and humid place.



■ How to prevent moisture condensation

When you bring your camcorder from a cold place into a warm place, put your camcorder in a plastic bag and seal it tightly. Remove the bag when the air temperature inside the plastic bag has reached the surrounding temperature (after about one hour).

Video head

- When the video head becomes dirty, you cannot record pictures normally, or distorted picture or sound is played back.
- If the following problem occurs, clean the video heads for 10 seconds with the Sony DVM-12CLD cleaning cassette (optional).
 - Mosaic-pattern noise appears on the playback picture or the screen is displayed in blue.



- Playback pictures do not move.
- Playback pictures do not appear or the sound breaks off.
- [] Dirty video head. Use a cleaning cassette.] appears on the screen during recording.
- [] Dirty video head. Use a cleaning cassette.] appears on the screen during playback.
- The video head suffers from wear after long use. If you cannot obtain a clear image even

Maintenance and precautions (Continued)

after using a cleaning cassette, it might be because the video head is worn. Please contact your Sony dealer or local authorized Sony service facility to have the video head replaced.

LCD screen

- Do not exert excessive pressure on the LCD screen, as it may cause damage.
- If your camcorder is used in a cold place, a residual image may appear on the LCD screen. This is not a malfunction.
- While using your camcorder, the back of the LCD screen may heat up. This is not a malfunction.

■ To clean the LCD screen

If fingerprints or dust make the LCD screen dirty, it is recommended you use a soft cloth to clean it. When you use the LCD Cleaning Kit (optional), do not apply the cleaning liquid directly to the LCD screen. Use cleaning paper moistened with the liquid.

■ On adjustment of the LCD screen (CALIBRATION)

The buttons on the touch panel may not work correctly. If this happens, follow the procedure below. It is recommended you connect your camcorder or the Handycam Station to the wall outlet using the supplied AC Adaptor during the operation.

- ① Slide the POWER switch down to turn on the PLAY/EDIT lamp.
- ② Disconnect cables other than that of the AC Adaptor from your camcorder or the Handycam Station, then eject the cassette and “Memory Stick Duo” from your camcorder.
- ③ Touch [P-MENU] → [MENU] →  (STANDARD SET) → [CALIBRATION] → [OK].
 - The screen changes to 16:9 ratio when using 4:3 ratio.

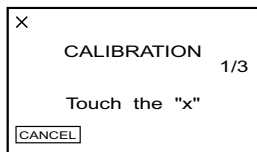

- ④ Touch the “x” displayed on the screen with the corner of the supplied “Memory Stick Duo.”
Touch [CANCEL] to cancel.

The position of the “x” changes. If you did not press the right spot, start from step ④ again.

- You cannot calibrate the LCD screen if it is rotated.

On handling the casing

- If the casing is soiled, clean the camcorder body with a soft cloth lightly moistened with water, and then wipe the casing with a dry soft cloth.
- Avoid the following to avoid damage to the finish.
 - Using chemicals such as thinner, benzene, alcohol, chemical cloths, repellent and insecticide.
 - Handling with above substances on your hands.
 - Leaving the casing in contact with rubber or vinyl objects for a long period of time.

About care and storage of the lens

- Wipe the surface of the lens clean with a soft cloth in the following instances:
 - When there are fingerprints on the lens surface.
 - In hot or humid locations
 - When the lens is exposed to salty air such as at the seaside.
- Store in a well-ventilated location subject to little dirt or dust.
- To prevent mold, periodically clean the lens as described above. It is recommended that you operate your camcorder about once a month to keep it in optimum state for a long time.

To charge the pre-installed rechargeable battery

Your camcorder has a pre-installed rechargeable battery to retain the date, time, and other settings even when the POWER switch is set to (CHG) OFF. The pre-installed rechargeable battery is always charged while your camcorder is connected to the wall outlet via the AC Adaptor or while the battery pack is inserted.

The rechargeable battery will be fully discharged in about **3 months** if you do not use your camcorder at all without the AC adaptor connected or the battery pack attached. However, even if the pre-installed rechargeable battery is not charged, the camcorder operation will not be affected as long as you are not recording the date.

■ Procedures

Connect your camcorder to a wall outlet using the supplied AC Adaptor or the Handycam Station, and leave it with the POWER switch set to (CHG) OFF for more than 24 hours.

To change the battery of the Remote Commander

- ① While pressing on the tab, inset your fingernail into the slit to pull out the battery case.
- ② Place a new battery with the + side facing up.
- ③ Insert the battery case back into the Remote Commander until it clicks.

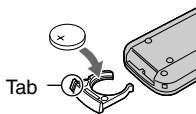

WARNING

Battery may explode if mistreated. Do not recharge, disassemble or dispose of in fire.

Caution

Danger of explosion if battery is incorrectly replaced. Replace only with the same or equivalent type recommended by the manufacturer.

Discard used batteries according to the manufacturer's instructions.

- When the lithium battery becomes weak, the operating distance of the Remote Commander may shorten, or the Remote Commander may not function properly. In this case, replace the battery with a Sony CR2025 lithium battery. Use of another battery may present a risk of fire or explosion.

Specifications

System

Video recording system	2 rotary heads, Helical scanning system
Still image recording system	Exif Ver. 2.2*1
Audio recording system	Rotary heads, PCM system Quantization: 12 bits (Fs 32 kHz, stereo 1, stereo 2), 16 bits (Fs 48 kHz, stereo)
Video signal	NTSC color, EIA standards
Usable cassette	Mini DV cassette with the ^{Mini} DV mark printed
Tape speed	SP: Approx. 18.81 mm/s LP: Approx. 12.56 mm/s
Recording/playback time	SP: 60 min (using a DVM60 cassette) LP: 90 min (using a DVM60 cassette)
Fast forward/rewind time	Approx. 2 min 40 s (using a DVM60 cassette and rechargeable battery pack) Approx. 1 min 45 s (using a DVM60 cassette and AC Adaptor)
Viewfinder	Electric viewfinder (color)
Image device	3.0 mm (1/6 type) 3 CMOS sensor Gross: Approx. 790 000 pixels Effective (still): Approx. 690 000 pixels Effective (movie): Approx. 670 000 pixels
Lens	Carl Zeiss Vario-Sonnar T* 10 × (Optical), 120 × (Digital)
Focal length	f=2.77 ~ 27.7 mm (1/8 ~ 1 1/8 in.) When converted to a 35 mm still camera In CAMERA-TAPE *2: 44 ~ 520 mm (1 3/4 ~ 20 1/2 in.) (16:9), 41 ~ 480 mm (1 5/8 ~ 19 in.) (4:3) In CAMERA-MEMORY: 40 ~ 400 mm (1 5/8 ~ 15 3/4 in.) (4:3), 43.5 ~ 435 mm (1 3/4 ~ 17 1/4 in.) (16:9) F1.8 ~ 2.4 Filter diameter: 30 mm (1 3/16 in.)

Color temperature [AUTO], [ONE PUSH], [INDOOR] (3 200 K), [OUTDOOR] (5 800 K)

Minimum illumination 7 lx (lux) (F 1.8)

*1“Exif” is a file format for still images, established by the JEITA (Japan Electronics and Information Technology Industries Association). Files in this format can have additional information such as your camcorder’s setting information at the time of recording.

*2The focal length figures are actual figures resulting from wide angle pixel read-out.

Input/Output connectors

Audio/Video input/output	10-pin connector Input/output auto switch Video signal: 1 Vp-p, 75 Ω (ohms), unbalanced Luminance signal: 1 Vp-p, 75 Ω (ohms), unbalanced Chrominance signal: 0.286 Vp-p, 75 Ω (ohms), unbalanced Audio signal: 327 mV (at load impedance 47 kΩ), Input impedance more than 47 kΩ (kilohms), Output impedance with less than 2.2 kΩ (kilohms)
LANC jack	Stereo mini-minijack (Ø 2.5 mm)

LCD screen

Picture	6.9 cm (2.7 type, aspect ratio 16:9)
Total dot number	123 200 (560 × 220)

General

Power requirements	DC 7.2 V (battery pack) DC 8.4 V (AC Adaptor)
Average power consumption	During camera recording using the viewfinder 3.0 W (when using the battery pack) During camera recording using the LCD 3.4 W (when using the battery pack)

Operating temperature	0 °C to 40 °C (32 °F to 104 °F)
Storage temperature	-20 °C to + 60 °C (-4 °F to + 140 °F)
Dimensions (approx.)	54 × 117 × 102 mm (2 1/4 × 4 5/8 × 4 1/8 in.) (w/h/d)
Mass (approx.)	400 g (14 oz) main unit only 470 g (1 lb) including the NP-FA50 rechargeable battery pack and DVM60 cassette.
Supplied accessories	See page 8.

Handycam Station Input/Output connectors DCRA-C140

Audio/Video input/output	10-pin connector Input/output auto switch Video signal: 1 Vp-p, 75 Ω (ohms), unbalanced Luminance signal: 1 Vp-p, 75 Ω (ohms), unbalanced Chrominance signal: 0.286 Vp-p, 75 Ω (ohms), unbalanced Audio signal: 327 mV (at load impedance 47 kΩ), Input impedance more than 47 kΩ (kilohms), Output impedance with less than 2.2 kΩ (kilohms)
USB jack	mini-B
DV jack	4-pin connector, S100

AC Adaptor AC-L200

Power requirements	AC 100 - 240 V, 50/60 Hz
Current consumption	0.35 - 0.18 A
Power consumption	18 W
Output voltage	DC 8.4 V*
Operating temperature	0 °C to 40 °C (32 °F to 104 °F)
Storage temperature	-20 °C to + 60 °C (-4 °F to + 140 °F)
Dimensions (approx.)	48 × 29 × 81 mm (1 15/16 × 1 3/16 × 3 1/4 in.) (w/h/d) excluding the projecting parts
Mass (approx.)	170 g (6.0 oz) excluding the power cord

* See the label on the AC Adaptor for other specifications.

Rechargeable battery pack (NP-FA50)

Maximum output voltage	DC 8.4 V
Output voltage	DC 7.2 V
Capacity	4.9 wh (680 mAh)
Dimensions (approx.)	47.2 × 6.8 × 75.5 mm (1 7/8 × 9/32 × 3 in.) (w/h/d)
Mass (approx.)	50 g (1.8 oz)
Operating temperature	0 °C to 40 °C (32 °F to 104 °F)
Type	Lithium ion

Design and specifications are subject to change without notice.

Index

Numeric

12BIT	54
16BIT	54
4CH MIC	55
4CH MIC recording	25, 55

A

A/V connecting cable	34, 63, 67, 84
A/V→DV OUT	56
A/V jack	34, 63, 67, 84
Access lamp	18
Active Interface Shoe	67, 72
AC Adaptor	9
Adjusting exposure for back light	25, 92
AE SHIFT	42, 96
ALL ERASE	47
Aspect ratio	19
Assignable dial	24, 61
AUDIO MIX	54, 68
AUDIO MODE	54
AUD DUB CTRL (Audio dubbing)	68
AUTO SHUTTER	41
A.SHUT OFF (Auto shut off)	58

B

BACK LIGHT	25, 92
Battery	
Battery pack	9
BATT INFO (Battery info)	26
Remaining battery	26
BEACH&SKI	40
BEEP	57
BLACK FADER	48
BURN DVD	53
BURST	45

Button-type lithium battery	115
B&W	50

C

Calibration	114
CAMERA COLOR	42
CAMERA DATA	57
CAMERA SET menu	40
CAM CTRL Dial	61
Cassette	17, 107
Insert/Eject	17
CD-ROM	73
Charging the battery	9
Battery pack	9
Pre-installed rechargeable battery	114
Charging time	12
CHG (charge) lamp	10
CINEMA EFFECT (Cinematic effect)	49
Click to DVD	81
CLOCK SET	16
COLOR SLOW S (Color Slow Shutter)	43, 95
Compression format	108
Computer	75
Connect	
Computer	73
TV	34, 63

D

DATA CODE	56
Date search	33
DATE/TIME	57
DC IN jack	9
DC plug	9
DELAY MOTION	50
Delete pictures	69
DEMO MODE	52, 86
DIAL SET	45

DIGITAL ZOOM	44, 92
DISPLAY BATT INFO button	14, 26
Display indicators	28
DISP GUIDE (Display guide)	15
DISP OUTPUT	57
DOT FADER	49
Double speed Playback	53
Dubbing	64
DV Interface	63
DV STREAM	52, 56
D. EFFECT (Digital effect)	49, 96

E

EASY button	20
Easy Handycam	20
EDIT SEARCH	31
END SEARCH	31, 53
END SEARCH/EDIT SEARCH/Rec review display switch button	28
ERASE	
ALL ERASE	47
Pictures	69
EXPOSURE	40, 95
EXP. BRKTG (Exposure bracketing)	45
EXP.FOCUS (Expanded focus)	42
EXT SUR MIC (External surround microphone)	55
EDIT/PLAY menu	53

F

FADER	48, 96
FILE NO. (File number)	47
FINE	45
First Step Guide	73, 80
Flash button	25, 91
FLASH LEVEL	43, 92

- FLASH (Flash motion) 50
 - FLASH SET 43
 - FOCUS 42, 92
 - Folder
 - NEW FOLDER 48
 - PB FOLDER
(Playback folder) 48
 - REC FOLDER
(Recording folder) 48
 - FORMAT 47, 108
 - Frame-by-frame playback 53
 - FRAME REC
(Frame recording) 51
 - Full charge 10
- G**
- GUIDEFAME 56
- H**
- Handycam Station 10, 72
 - Help 73
 - HISTOGRAM 44, 96
 - Holding the camcorder 13
- I**
- Icon See Display indicators
 - ImageMixer VCD2 73
 - Image delete button 29
 - Image protection 69
 - Image quality (QUALITY) .. 45
 - Image size (IMAGE SIZE) .. 46
 - Movie 47
 - Still image 46
 - Index screen 23
 - Index screen display button .. 29
 - Indicators 30
 - INDOOR 41
 - "InfoLITHIUM" battery pack
..... 110
 - Initialize (Reset) 26
 - Install 75
 - Insulation sheet 32
 - Interface connector 72
 - Internal microphone 27
 - INT.REC-STL
(Interval photo recording) 51
 - i.LINK 111
 - i.LINK cable 63, 81, 84
- J**
- Jack 72
 - JPEG 108
- L**
- Label 107
 - LANC jack 72
 - LANDSCAPE 40
 - LANGUAGE 58
 - LCD/VF SET 55
 - LCD backlight 14, 88
 - LCD BL LEVEL
(LCD back light) 55
 - LCD BRIGHT 55
 - LCD COLOR 56
 - LCD PANEL 57
 - LCD panel 14
 - LCD BL LEVEL 55
 - LCD BRIGHT 55
 - LCD COLOR 56
 - LCD screen 15
 - Lens cover 22
 - LETTER BOX 56
 - Lid 17
 - LP (Long Play) 54
 - LUMI. KEY (Luminance key)
..... 50
- M**
- Macintosh 74, 79
 - Maintenance 112
 - Main sound 54
 - MANUAL button 61
 - MEMORY SET menu 45
 - "Memory Stick" 52, 108
 - "Memory Stick Duo" 17
 - FORMAT 47
 - Insert/Eject 18
 - Number of recordable
pictures 46
 - Recordable time 47
 - Write-protect tab 108
 - Memory Stick Duo adaptor
..... 8, 109
 - "Memory Stick Duo" slot ... 18
 - Menu 36
 - CAMERA SET menu ... 40
 - EDIT/PLAY menu 53
 - MEMORY SET menu .. 45
 - Menu items 38
 - Personal Menu 36, 59
 - PICT.APPLI. menu 48
 - STANDARD SET menu
..... 54
 - TIME/LANGU. menu .. 58
 - Using the menu 36
 - MENU ROTATE 58
 - Mirror mode 25
 - Moisture condensation 113
 - MONOTONE 48
 - MOSAIC 50
 - MOSAIC FADER 48
 - Movie
 - Movie format 108
 - REC MODE
(Recording mode) 54
 - MOVIE SET 47
 - MPEG 108
 - MPEG MOVIE EX 22
 - MULTI CONNCT 52
 - MULTI-SOUND 54

N

NEG.ART 50
 NEW FOLDER 48
 NORMAL 45
 NTSC 106
 Number of recordable pictures 46

O

OLD MOVIE 50
 ONE PUSH 41
 OPEN/EJECT lever 17
 Operation confirmation beep See BEEP
 OUTDOOR 41
 OVERLAP 49

P

PAL 94, 106
 PASTEL 50
 PB FOLDER (Playback folder) 48
 PB zoom 26
 Personal Menu 36, 59
 Add 59
 Arrange the order 60
 Customize 59
 Delete 59
 Reset 60
 Use 36
 Personal Menu button 28
 PHOTO button 20, 22, 32
 PictBridge 70
 PictBridge PRINT 70
 Picture Package 73
 Picture Search 23
 PICT.APPLI. menu (Picture Application menu) 48
 PICT. EFFECT (Picture effect) 50

Pixela user support center 80
 Playback 23
 Double speed 53
 Frame 53
 Reverse 53
 Slow 53
 Playing time 12
 PORTRAIT (Soft portrait) ... 40
 Power cord 9
 POWER switch 13
 Previous/Next image button 29
 Print 70
 Print mark 70
 PROGRAM AE 40, 95
 PROGRES.REC 44, 96
 P.MENU See Personal Menu

Q

QUALITY 45

R

Rechargeable battery pack See Battery
 Recording 22
 Recording capacity 28
 Recording time 12, 47
 REC CTRL (Recording control) 65
 REC FOLDER (Recording folder) 48
 REC LAMP 57
 REC lamp (Recording lamp) 27
 REC MODE (Recording mode) 54
 REC MOVIE 66
 Rec review 31
 REC START/STOP 20, 22
 REDEYE REDUC 43
 REMAINING 57

Remaining battery 28
 Remote Commander 32
 REMOTE CTRL (Remote control) 57
 Remote sensor 27
 RESET button 26
 Reversal Playback 53
 Review button 28

S

Searching for the starting point 31
 Self-diagnosis display 101
 SELF-TIMER 44
 SEPIA 50
 Setting the date and time 16
 SHARPNESS 41, 95
 Shoulder Strap 8
 Signal convert function 84
 SKINTONE 50, 96
 Skip Scan 23
 SLIDE SHOW 49
 Slow Playback 53
 SLOW SHUTTR (Slow shutter) 50
 SMTH INT.REC (Smooth interval recording) 51, 96
 Software 75
 SOLARIZE 50
 SP (Standard Play) 54
 Speaker 27
 Specifications 116
 SPOTLIGHT 40
 SPOT FOCUS 42, 95
 SPOT METER (Flexible spot meter) 40, 95
 SQUEZE (Squeeze) 56
 STANDARD 46
 STANDARD SET menu 54
 STEADYSHOT 44, 92
 STEREO 55

STILL.....	50
Still image	
Image size	46
Quality	45
Still image format	108
STILL SET.....	45
Strap Belt	13
Sub sound.....	54
SUNSET&MOON	40
System requirement	74
S VIDEO cable.....	34, 63
S VIDEO jack	34, 63

T

Tape	See Cassette
Tape counter	28
Tape playback select button	29
Telephoto.....	24
TELE MACRO	43, 95
TIME/LANGU. menu.....	58
Time code.....	28
Touch panel	15
Trademark	123
TRAIL.....	50
Transmitter.....	32
Tripod.....	25
TV	34
TV color systems	106
TV TYPE	34

U

USB CAMERA.....	56
USB jack.....	72
USB ON/OFF switch.....	72
USB SELECT	52
Using abroad.....	106

V

VAR.SPD PB (Various speed playback).....	53
VF B.LIGHT (Viewfinder brightness).....	56
VF WIDE DISP (Viewfinder wide)	56
Video head	113
VIDEO INPUT	56
Video operation buttons	29
Viewfinder.....	14
Brightness	56
Viewfinder lens adjustment lever.....	14
VOLUME.....	54
Volume	23
V-OUT/PANEL.....	57

W

Warning indicators	101
Warning messages.....	101
WB SHIFT (White Balance Shift)	42
WHITE BAL. (White balance)	41
White Balance Shift	42
WHITE FADER.....	48
Wide angle	24
WIDE SELECT	19
WIDE STEREO	55
Windows	74, 75
WIPE.....	49
WORLD TIME	58
Write-protect tab	107, 108

Z

ZEBRA	43
Zero set memory	32
ZERO SET MEMORY button	32
Zoom.....	24
Zoom lever	24

On trademarks

- “Memory Stick,”  “MEMORY STICK™,” “Memory Stick Duo,” “**MEMORY STICK DUO**,” “Memory Stick PRO Duo,” “**MEMORY STICK PRO DUO**,” “MagicGate,” “**MAGICGATE**,” “MagicGate Memory Stick” and “MagicGate Memory Stick Duo” are trademarks or registered trademarks of Sony Corporation.
- “InfoLITHIUM” is a trademark of Sony Corporation.
- i.LINK and  are trademarks of Sony Corporation.
- Picture Package is a trademark of Sony Corporation.
- Mini  is a trademark.
- Microsoft, Windows, and Windows Media are trademarks or registered trademarks of U.S. Microsoft Corporation in the U.S. and other countries.
- iMac, iBook, Macintosh, Mac OS, PowerBook and PowerMac are trademarks of Apple Computer, Inc in the U.S. and other countries.
- eMac is trademark of Apple Computer, Inc.

- QuickTime and the QuickTime logo are trademarks of Apple Computer, Inc.
- Roxio is a registered trademark of Roxio, Inc.
- Toast is a trademark of Roxio, Inc.
- Windows Media Player is a trademark of Microsoft Corporation.
- Macromedia and Macromedia Flash Player are trademarks or registered trademarks of Macromedia, Inc. in the United States and other countries.
- Pentium is a trademark or registered trademark of Intel Corporation.

All other product names mentioned herein may be the trademarks or registered trademarks of their respective companies. Furthermore, TM and [®] are not mentioned in each case in this manual.